

**GPM/DPR
TRMM/PR
L1 Product Format Documentation**

Product Version 5

Version 3.1

October, 2017

Japan Aerospace Exploration Agency

Revision history

revision	date	section	content, reason
Version 1.0	Sept. 2 nd 2014	ALL	New
Version 2.0	Mar. 7 th 2016	ALL	Modification of layout
		P10, P 52, P 58, P 64, P 69	Modified of elements in HouseKeeping data group. Addition of rxGain, ScdpFlagAB and FcifAB into HouseKeeping data group.
		P17	Modification of information of TotalQualityCode.
Version 3.0	May 9 th 2017	P5, P27, P65, P71	Addition of receivedPulseWidth into Receiver data group.
		P12	Addition of DOIauthority and DOIshortName into FileHeader meta data.
		P18	Modification of transReceiptCoefVersion to transReceiverCoefVersion, and addition of totalCoefVersion into DPRKuInfro and DPRKaInfo meta data.
Version 3.1	Oct. 1 st 2017	Front cover	Addition of TRMM/PR and Product Version 5.
		P2-3, P18, P31, P39, P58	Addition of TRMM/PR information.

Reference

- (1) RECIPITATION PROCESSING SYSTEM, GLOBALPRECIPITATION MEASUREMENT, File Specification for GPM Products
- (2) PRECIPITATION PROCESSING SYSTEM GLOBAL PRECIPITATION MEASUREMENT Metadata for GPM Products

Table of Contents

1. Data Format Structure	1
1.1 Dimension Definition	2
1.2 Data Format Structure for 1BKu	3
1.3 Data Format Structure for 1BKa.....	4
1.4 Data Format Structure for each Group	5
2. Contents of Objects in each Group	11
2.1 Metadata	12
2.1.1 FileHeader	12
2.1.2 InputRecord.....	14
2.1.3 NavigationRecord	14
2.1.4 FileInfo	16
2.1.5 JAXAInfo	17
2.1.6 DPRKuInfo	18
2.1.7 DPRKaInfo	18
2.1.8 SwathHeader	19
2.2 Data Group	20
2.2.1 ScanTime (Group).....	21
2.2.2 Latitude	23
2.2.3 Longitude.....	23
2.2.4 Receiver (Group)	23
2.2.5 Transmitter (Group).....	25
2.2.6 VertLocate (Group)	27
2.2.7 scanStatus (Group).....	33
2.2.8 navigation (Group).....	41
2.2.9 rayPointing (Group)	45
2.2.10 HouseKeeping (Group).....	46
2.2.11 Calibration (Group).....	55
3. The List of Elements of the Data Group.....	57
3.1 The List of Elements of NS Data Group of 1BKu.....	58
3.2 The List of Elements of MS Data Group of 1BKa	64
3.3 The List of Elements of HS Data Group of 1BKa.....	70
Index.....	3-76

1. Data Format Structure

1.1 Dimension Definition

Dimension definitions:

- nscan
 - Number of scans in the granule.
- nray
 - 49 Number of angle bins in each scan. (NS)
 - 25 Number of angle bins in each scan. (MS)
 - 24 Number of angle bins in each scan. (HS)
- nbin
 - 260 Number of range bins in each ray. (NS)
 - 260 Number of range bins in each ray. (MS)
 - 130 Number of range bins in each ray. (HS)

“NS” is called as Normal scan Swath in 1BKu and 1BPR.

“MS” is called as Matched beam scan Swath and “HS” is called as High sensitivity beam scan Swath in 1BKa respectively.

1.2 Data Format Structure for 1BKu

The Ku Level-1B product, 1BKu, is defined as a swath structure, which is called “NS”. The PR Level-1B product, 1BPR, is the same with 1BKu and there are no differences between 1BKu and 1BPR.

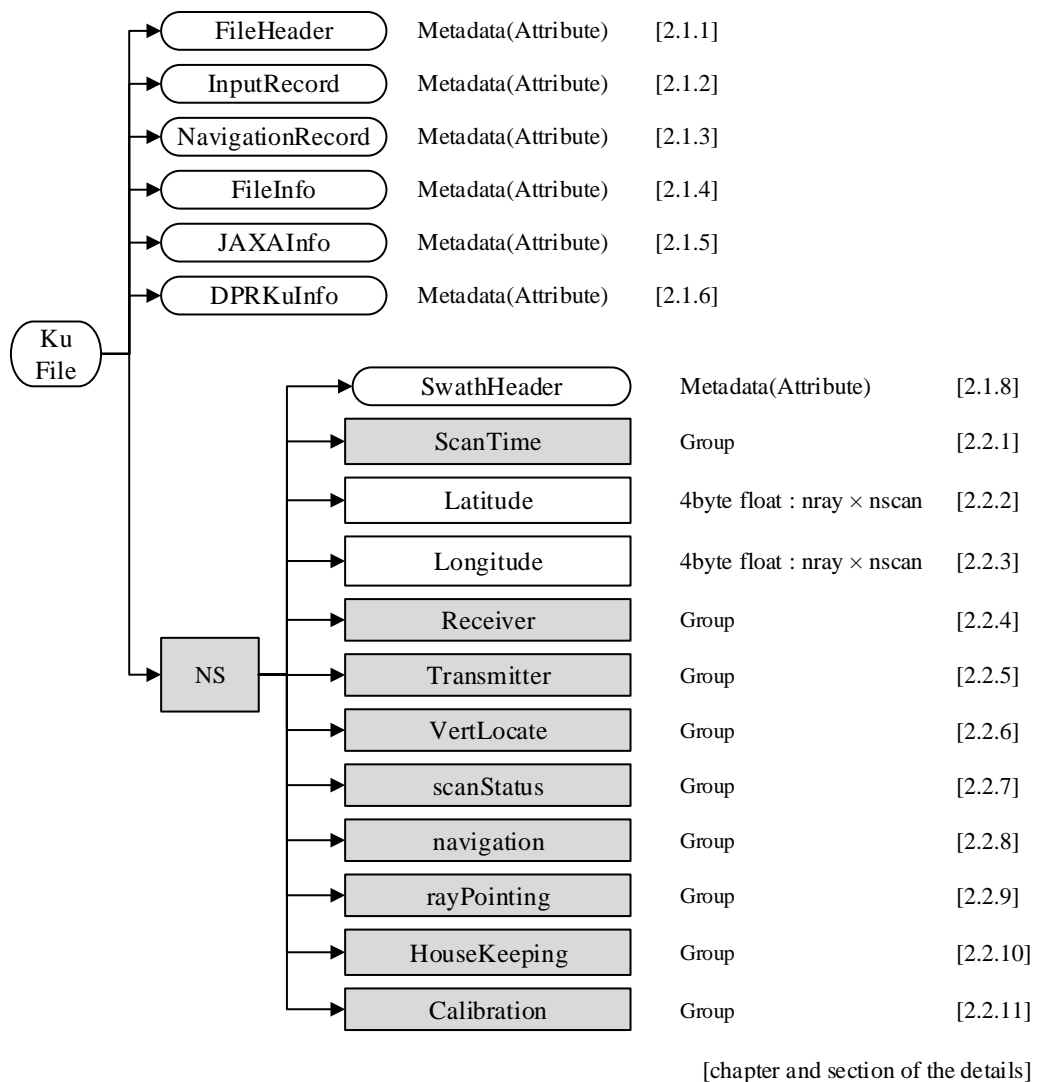
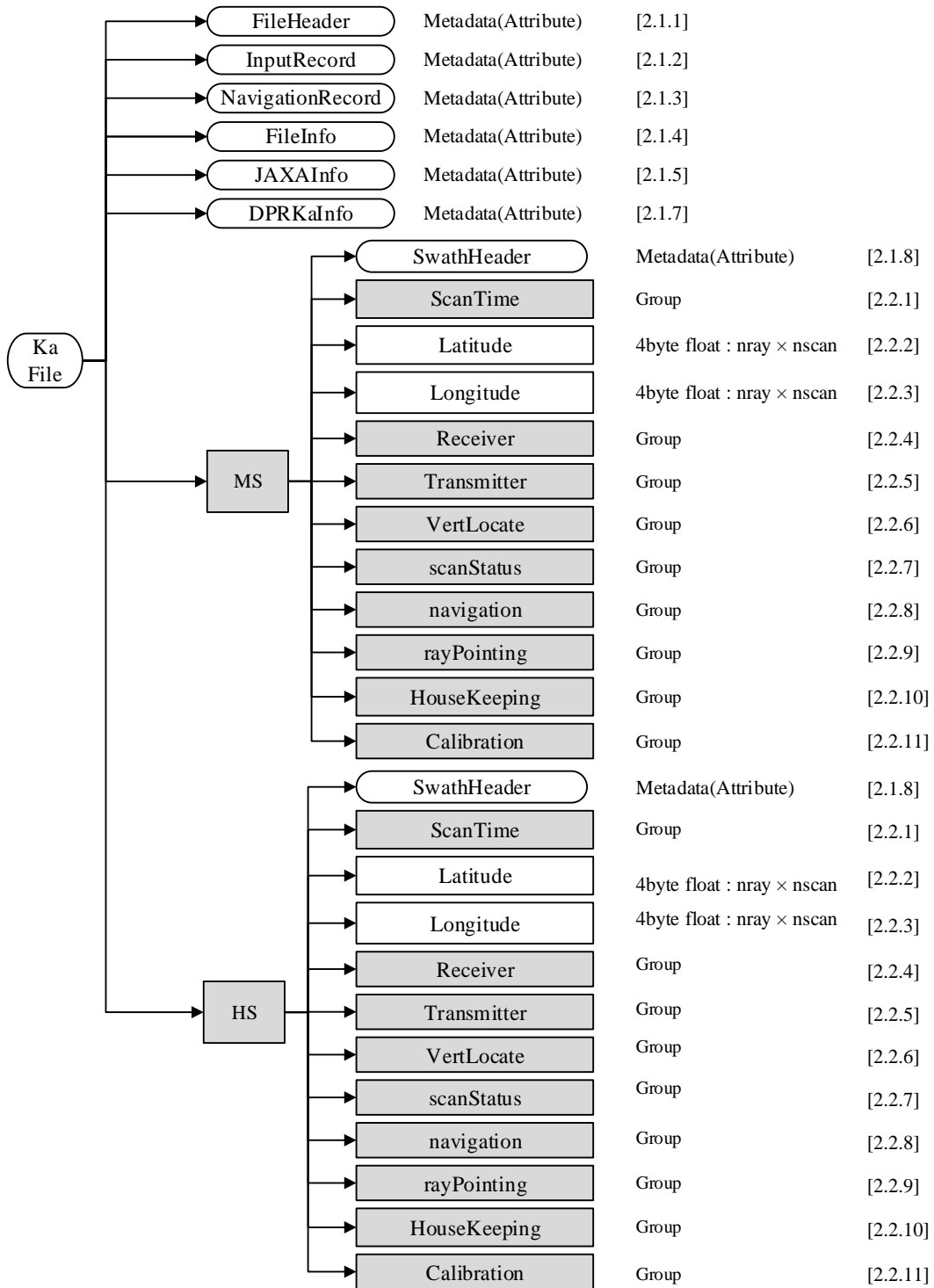

Figure1.2-1 Data Format Structure for 1BKu

1.3 Data Format Structure for 1BKa

The Ka Level-1B product, 1BKa, is defined as two-swath structures, which are called “MS” and “HS”.



[chapter and section of the details]

Figure1.3-1 Data Format Structure for 1BKa

1.4 Data Format Structure for each Group

Each group's structure is shown in this section. Structures in each swath are common. However, the number of rays and range bins are different as shown in section 1.1.

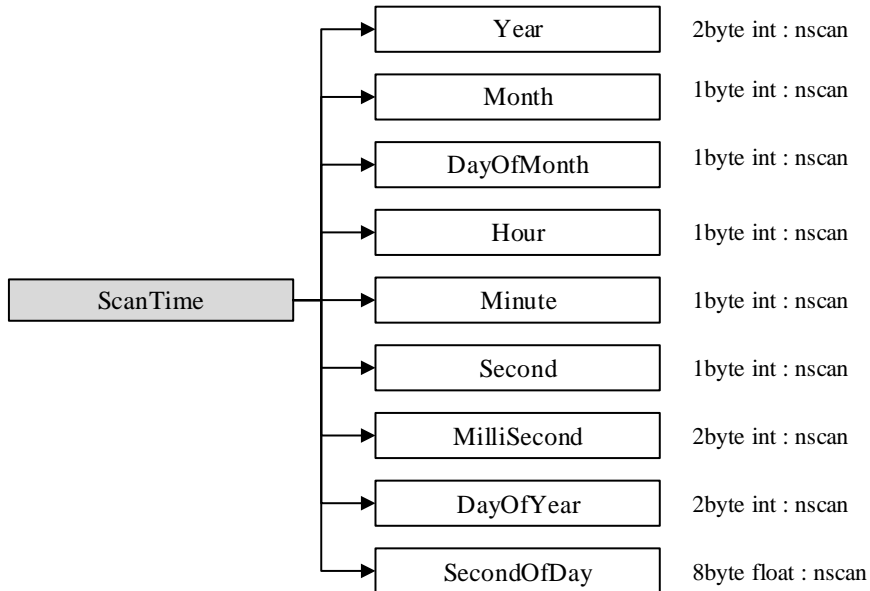

Figure1.4-1 Data Format Structure for ScanTime Group

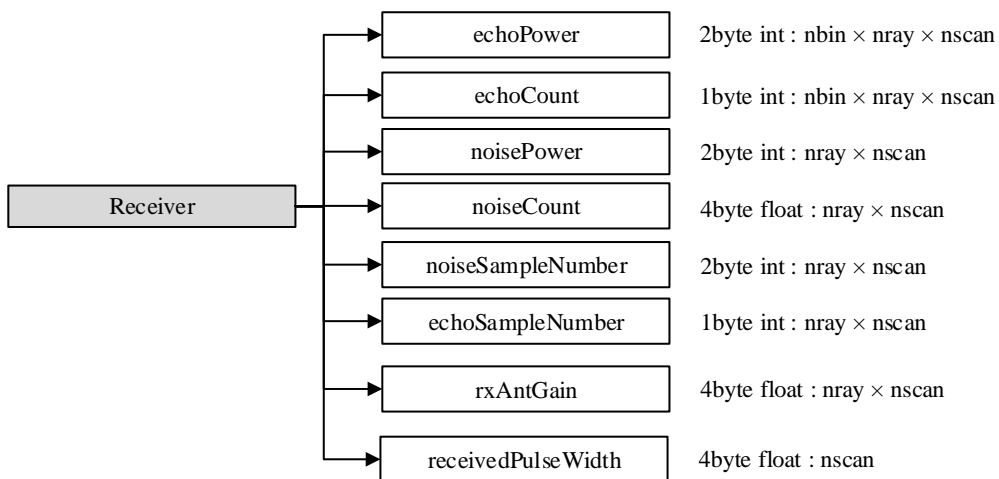

Figure1.4-2 Data Format Structure for Receiver Group

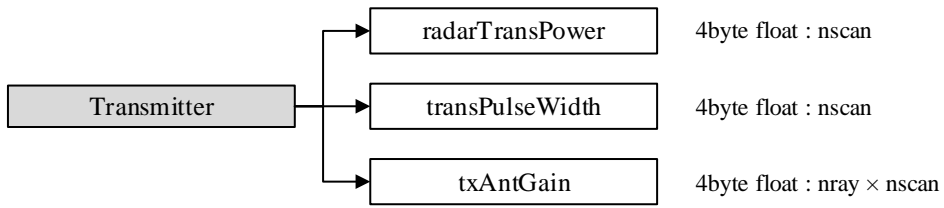

Figure1.4-3 Data Format Structure for Transmitter Group

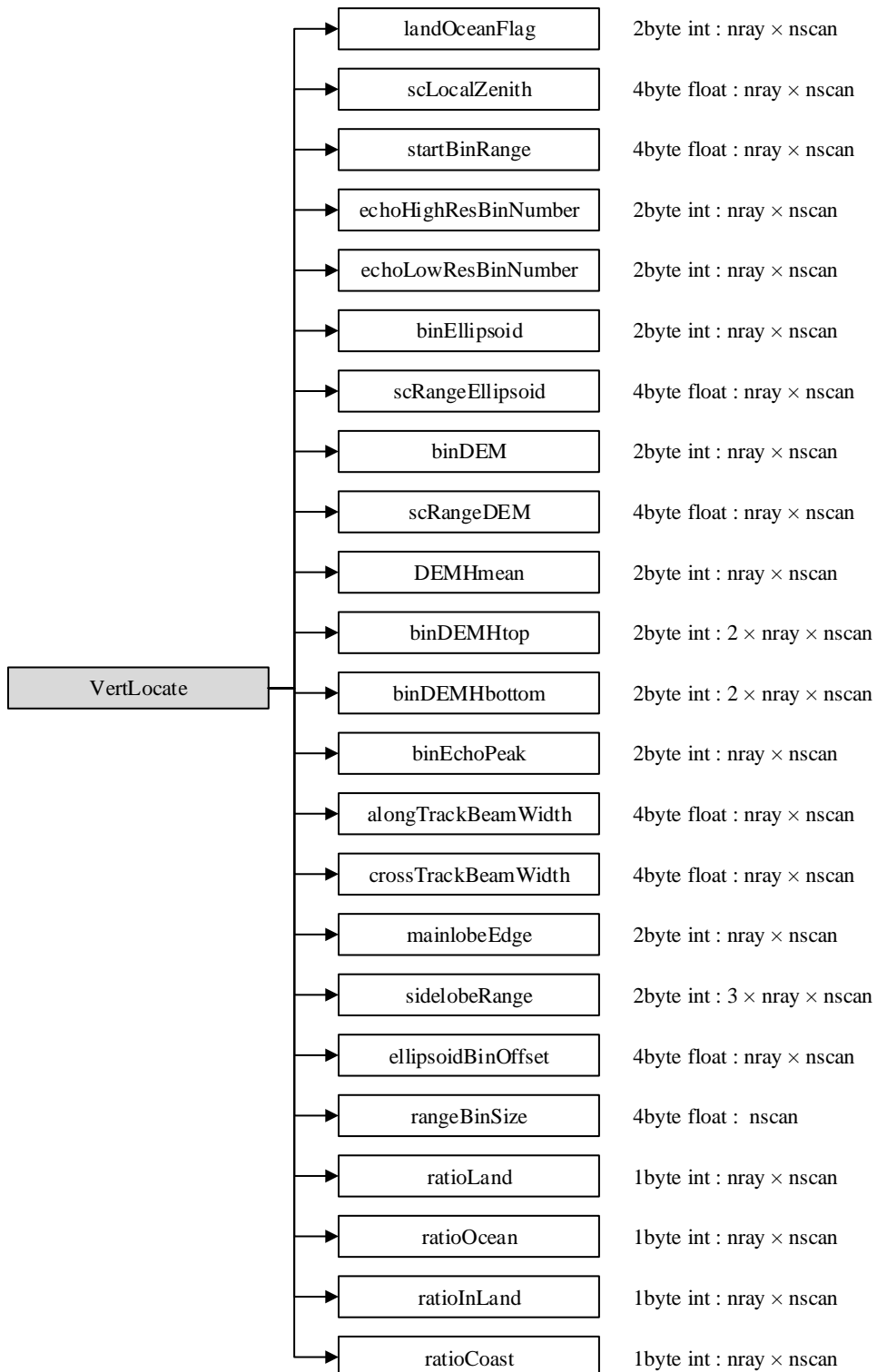

Figure1.4-4 Data Format Structure for VertLocate Group

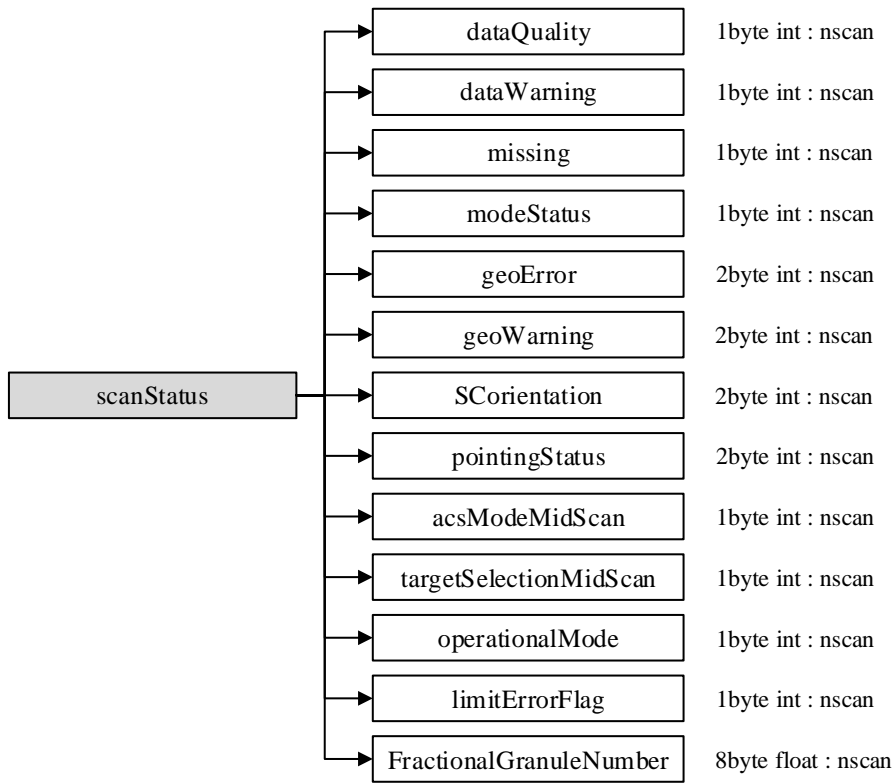

Figure1.4-5 Data Format Structure for scanStatus Group

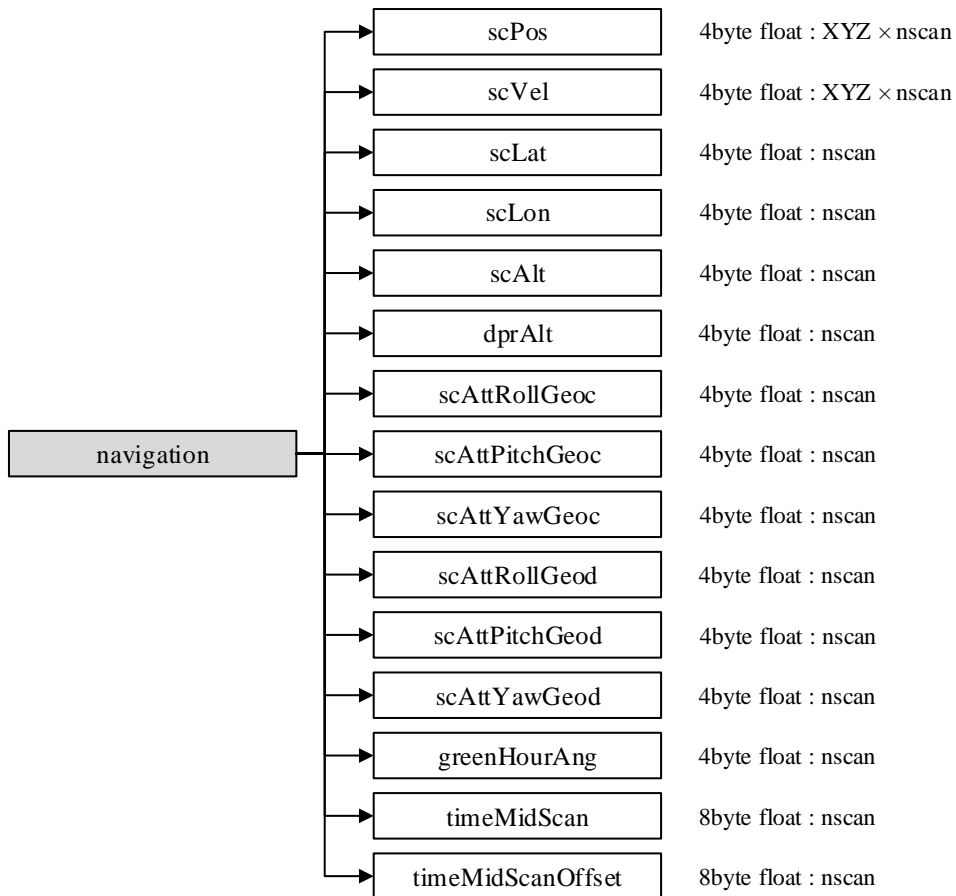

Figure1.4-6 Data Format Structure for navigation Group

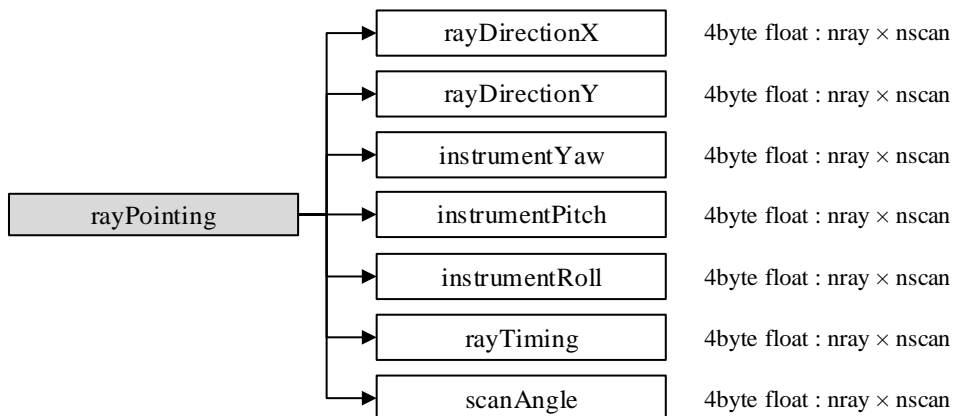

Figure1.4-7 Data Format Structure for rayPointing Group

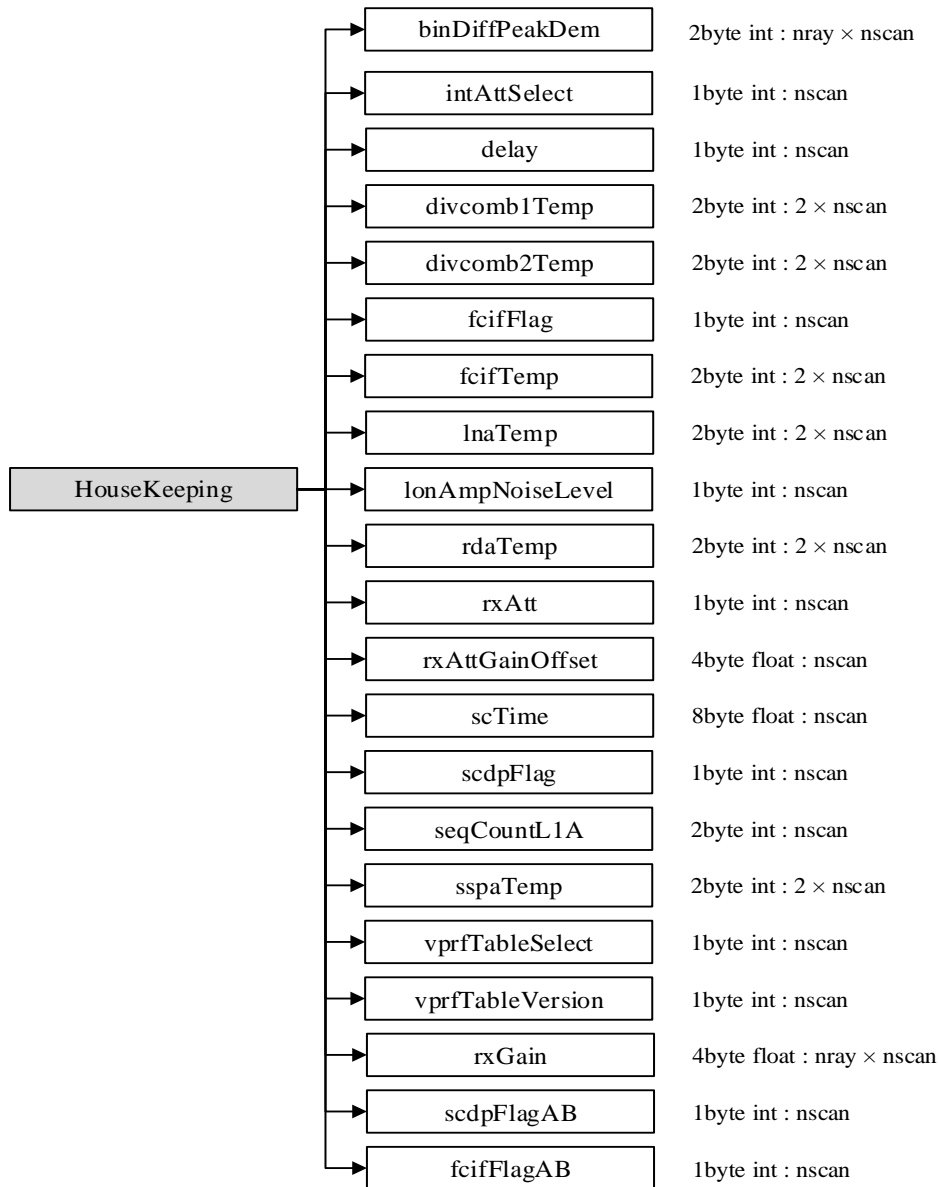

Figure1.4-8 Data Format Structure for HouseKeeping Group

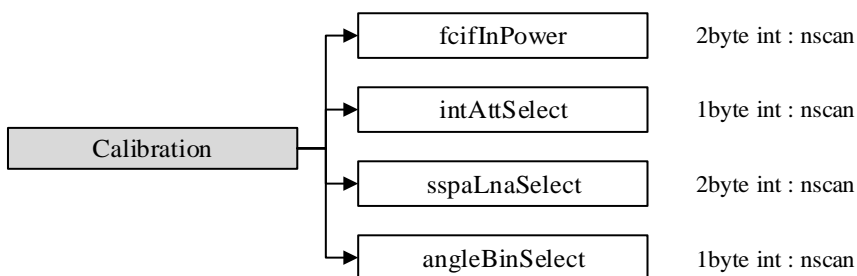

Figure1.4-9 Data Format Structure for Calibration Group

2. Contents of Objects in each Group

2.1 Metadata

Metadata has seven elements. Figure 2.1-1 shows metadata structure.

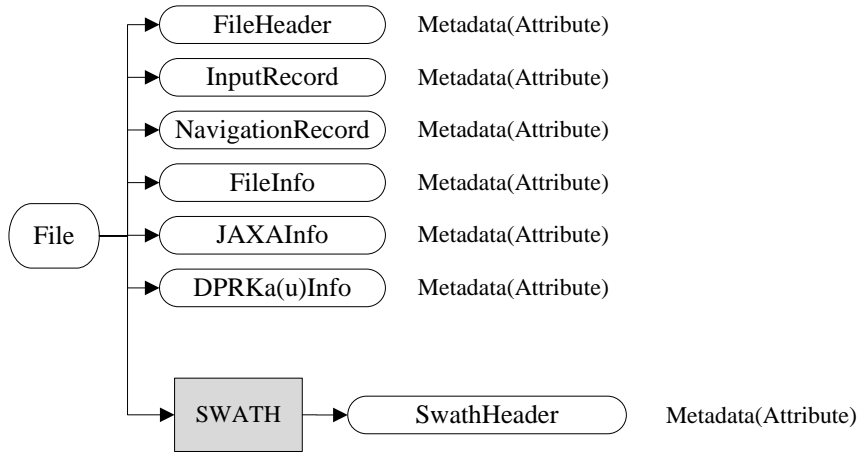

Figure2.1-1 DPR L1B Metadata

2.1.1 FileHeader

FileHeader contains metadata of general interest. This group appears in all data products. Table 2.1.1-1 shows each metadata elements in FileHeader.

Table2.1.1-1 FileHeaderElements

No	Element	Description	Data size (bytes)
1	DOI	Digital Object Identifier with DOIauthority and DOIshortName. *Value is blank currently.	256
2	DOIauthority	Digital Object Identifier Authority.	256
3	DOIshortName	Digital Object Identifier Short Name. *Value is blank currently.	256
4	AlgorithmID	The algorithm that generated this product, e.g., 2A12.	50
5	AlgorithmVersion	The version of the algorithm that generated this product.	50
6	FileName	The file name of this granule.	50

2.1 Metadata

2.1.1 FileHeader

No	Element	Description	Data size (bytes)
7	SatelliteName	Values are: TRMM GPM MULTI F10 ... F18 AQUAGCOMW1 CORIOLIS MT1 NOAA15 ... NOAA19 METOPANPP. More values will be added as they are known.	10
8	InstrumentName	Values are: PR TMI VIRS PRTMI KU KA DPR GMIDPRGMI MERGED SSMI SSMIS AMSRE AMSR2 WINDSATMADRAS AMSUA AMSUB SAPHIR MHS ATMS. More values will be added as they are known.	10
9	GenerationDateTime	The date and time this granule was generated. The format is YYYY-MM-DDTHH:MM:SS.sssZ, where YYYY is 4-digit year, MM is month number, DD is day of month, T is "T", HH is hour, MM is minute, SS is second, sss is millisecond, and Z is "Z". All fields are zero-filled. The missing value is constructed by replacing all digits with 9, i.e., 9999-99-99T99:99:99.999Z.	50
10	StartGranuleDateTime	The start time defining this granule. The format is the same as GenerationDateTime. DETAILS: An orbital granule starts when the satellite is at the position defined by GranuleStart. Thus the start time is not the first scan time. Some algorithms have overlap scans in the file before the start time as defined in SwathHeader. A monthly granule starts on the first ms of the month, for example March 1998 would be 1998-03-01T00:00:00.000Z.	50
11	StopGranuleDateTime	The stop time defining this granule. The format is the same as GenerationDateTime. DETAILS: An orbital granule stops when the satellite is at the position defined by GranuleStart. Thus the stop time is not the last scan time. Some algorithms have overlap scans in the file after the stop time as defined in SwathHeader. A monthly granule stops on the last ms of the month, for example March 1998 would be 1998-03-31T23:59:59.999Z.	50
12	GranuleNumber	The number of this granule, which starts as in GranuleStart. If the GranuleStart is identical to the orbit start, then the GranuleNumber will be the same as the orbit number. The GranuleNumber will have 6 digits, including leading zeroes, for example 001234.	50
13	NumberOfSwaths	The number of swaths in this granule.	50
14	NumberOfGrids	The number of grid structures in this granule.	50
15	GranuleStart	The starting place in the orbit of this granule. Currently defined values are "SOUTHERNMOST LATITUDE" and "NORTHBOUND EQUATOR CROSSING".	50
16	TimeInterval	The time interval covered by this granule. Values are "ORBIT", "HALF ORBIT", "HALF HOUR", "HOUR", "3 HOUR", "DAY", "DAY ASC", "DAY DES", "MONTH", "CONTACT".	50
17	ProcessingSystem	The name of the processing system, e.g., "PPS", "JAXA".	50
18	ProductVersion	The data version assigned by the processing system.	50
19	EmptyGranule	Whether a granule is empty. Values are "EMPTY" or "NOT EMPTY".	50
20	MissingData	The number of missing scans.	50

2.1.2 InputRecord

InputRecord contains a record of input files for this granule. This group appears in Level 1, Level 2, and Level 3 orbital data products. Level 3 time averaged products have the same information separated into 3 groups since they have many inputs. Table 2.1.2-1 shows each metadata element in InputRecord.

Table 2.1.2-1 InputRecordElements

No	Element	Description	Data size (bytes)
1	InputFileNames	A list of input file names for this granule.	1000
2	InputAlgorithmVersions	A list of algorithm versions of the input files for this granule.	1000
3	InputGenerationDateTimes	A list of generation date times of the input files for this granule. The format is the same as GenerationDateTime.	1000

2.1.3 NavigationRecord

NavigationRecord contains navigation metadata for this granule. This group appears in Level 1, Level 2, and Level 3 orbital data products. Table 2.1.3-1 shows each metadata element in NavigationRecord.

Table 2.1.3-1 NavigationRecordElements

No	Element	Description	Data size (bytes)
1	LongitudeOnEquator	The longitude where the satellite crosses the equator going from south to north.	50
2	UTCDateTimeOnEquator	The UTC time when the satellite crosses the equator going from south to north. The format is the same as GenerationDate Time.	50
3	MeanSolarBetaAngle	The average solar beta angle in this granule.	50
4	EphemerisFileName	Name of the ephemeris file input for processing.	50
5	AttitudeFileName	Name of the attitude file input for processing.	50
6	GeoControlFileName	Name of the GeoTK Control Parameters File input for processing.	50

2.1 Metadata

2.1.3 NavigationRecord

No	Element	Description	Data size (bytes)
7	EphemerisSource	Values are "0 CONSTANT INPUT TEST VALUE", "1 GROUND ESTIMATED STATE (GES)", "2 GPS FILTERED SOLUTION (GEONS)", "3 GPS POINT SOLUTION (PVT)", "4 ON BOARD PROPAGATED (OBP)", "5 OEM GROUND EPHEMERIS FILE", "6 GEONS WITH FALLBACK AS FLAGGED", "7 PVT WITH FALLBACK AS FLAGGED", "8 OBP WITH FALLBACK AS FLAGGED", "9 GES WITH FALLBACK AS FLAGGED".	50
8	AttitudeSource	values are "0 CONSTANT INPUTS FOR TESTING", "1 ON BOARD CALCULATED PITCH ROLL YAW".	50
9	GeoToolkitVersion	Version of the GeoToolkit.	50
10	SensorAlignmentFirstRotationAngle	Alignment angle, first rotation, in degrees. Rotation adjustment from sensor coordinates to the Attitude Control System Flight Coordinates.	50
11	SensorAlignmentSecondRotationAngle	Alignment angle, second rotation, in degrees.	50
12	SensorAlignmentThirdRotationAngle	Alignment angle, third rotation, in degrees.	50
13	SensorAlignmentFirstRotationAxis	Euler rotation sequence, first rotation axis. Values are "1", "2", "3" (representing X, Y, Z).	50
14	SensorAlignmentSecondRotationAxis	Euler rotation sequence, second rotation axis. Values are "1", "2", "3" (representing X, Y, Z).	50
15	SensorAlignmentThirdRotationAxis	Euler rotation sequence, third rotation axis. Values are "1", "2", "3" (representing X, Y, Z).	50

2.1.4 FileInfo

FileInfo contains metadata used by the PPS I/O Toolkit. This group appears in all data products. Table 2.1.4-1 shows each metadata elements in FileInfo.

Table 2.1.4-1 FileInfoElements

No	Element	Description	Data size (bytes)
1	DataFormatVersion	The version of the data format used to write this file. This version is separate for each AlgorithmID. The order is: "a" "b" ... "z" "aa" "ab" ... "az" "ba" "bb".	50
2	TKCodeBuildVersion	Usually TK CodeBuildVersion is "1". If the I/O routines built by TKIO change even though the DataFormatVersion is unchanged, then TK CodeBuildVersion increments to "2", "3", ...If subsequently DataFormatVersion changes, TKCodeBuildVersion becomes "1" again.	50
3	MetadataVersion	The version of metadata used to write this file. This version is separate for each AlgorithmID. The order is: "a" "b" ... "z" "aa" "ab" ... "az" "ba" "bb" ...	50
4	FormatPackage	The underlying format of this granule. Values are "HDF4", "HDF5", "NETCDF", "TKBINARY".	50
5	BlueprintFilename	The filename of the primary blueprint file that defined the format used to write this file.	50
6	BlueprintVersion	The BlueprintVersion of the format definition.	50
7	TKIOVersion	The version of TKIO used to create I/O routines to write this file. TKIOVersion does not define the format used to write this file.	50
8	MetadataStyle	The style in which the metadata was written, e.g., "PVL". "PVL" means < parameter >=< value >.	50
9	EndianType	The endian type of the system that wrote this file. Values are "BIG ENDIAN" and "LITTLE ENDIAN".	50

2.1.5 JAXAInfo

JAXAInfo contains metadata requested by JAXA.Used by DPR algorithms and GSMaP. Table 2.1.5-1 shows each metadata elements in JAXAInfo.

Table 2.1.5-1 JAXAInfoElements

No	Element	Description	Data size (bytes)
1	GranuleFirstScanUTCDateTime	Granule First Scan UTC Date. Date is a 24 character string. The format is YYYY-MM-DDTHH:MM:SS.sssZ, where YYYY is 4-digit year, MM is month number, DD is day of month, T is "T", HH is hour, MM is minute, SS is second, sss is millisecond, and Z is "Z". All fields are zero-filled. The missing value is constructed by replacing all digits with 9, i.e.,9999-99-99T99:99:99.999Z.	50
2	GranuleLastScanUTCDateTime	Granule Last Scan UTC Date. Date is a 24 character string. The format is YYYY-MM-DDTHH:MM:SS.sssZ, where YYYY is 4-digit year, MM is month number, DD is day of month, T is "T", HH is hour, MM is minute, SS is second, sss is millisecond, and Z is "Z". All fields are zero-filled.	50
3	TotalQualityCode	The total quality of GPM KuPR/KaPR L1B product is defined based on the number of missing scans. Quality meaning are Good: missing scans > 0 EG(Empty Granule): missing scans = 0	50
4	FirstScanLat	Latitude of orbit first scan.	50
5	FirstScanLon	Longitude of orbit first scan.	50
6	LastScanLat	Latitude of orbit last scan.	50
7	LastScanLon	Longitude of orbit last scan.	50
8	NumberOfRainPixelsNS	Number of rain pixels in the NS swath, judged at DPR L2 algorithm. At DPR L1, value is "-9999".	50
9	NumberOfRainPixelsMS	Number of rain pixels in the MS swath, judged at DPR L2algorithm. At DPR L1, value is "-9999".	50
10	NumberOfRainPixelsHS	Number of rain pixels in the HS swath, judged at DPR L2algorithm. At DPR L1, value is "-9999".	50
11	ProcessingSubSystem	The name of the processing sub-system, e.g., "ALGORITHM","PCS".	50
12	ProcessingMode	The name of the processing mode, e.g., "STD","NRT".	50
13	lightspeed	Constant value of light speed.	50
14	dielectricConstantKu	The parameter of dielectric for Ku.	50

2.1 Metadata

2.1.6 DPRKuInfo

No	Element	Description	Data size (bytes)
15	dielectricConstantKa	The parameter of dielectric for Ka.	50

2.1.6 DPRKuInfo

DPR KuInfo contains DPR Ku and PR information. This group appears in 1BKu and 1BPR. Table 2.1.6-1 shows each metadata elements in DPRKuInfo.

Table 2.1.6-1 DPRKuInfoElements

No	Element	Description	Data size (bytes)
1	scanAngleObsVersion	The version of scan angle table which is used for non-external calibration mode.	100
2	scanAngleExtVersion	The version of scan angle table which is used for external calibration mode.	100
3	transReceiverCoefVersion	The version of trans/receipt gain correction value table.	100
4	totalCoefVersion	Total version of calibration coefficients. It consists of FCIF IO table version and transmitter and receiver gain correction table version.	100
5	fcifIoTableVersion	The version of FCIF I/O table.	100
6	eqvWavelength	Equivalent wavelength (m).	100
7	logAveOffset	The offset value (dB) between logarithmic average and normal average.	100
8	alignmentAngleBasicEtoA	Rotation angle (degrees) from electrical axis to antenna axis.	100
9	alignmentAngleOffsetAtoM	Offset angle (degrees) from antenna axis to mechanical axis.	100

2.1.7 DPRKaInfo

DPR KaInfo contains DPR Ka information. This group appears in 1BKa. It is same as DPRKuInfo. Please see “2.1.6-1 DPRKuInfo”.

2.1.8 SwathHeader

SwathHeader contains metadata for each swath. This group appears in Level 1 and Level 2 data products. Table 2.1.8-1 shows each metadata elements in SwathHeader.

Table 2.1.8-1 SwathHeaderElements

No	Element	Description	Data size (bytes)
1	NumberScansInSet	The scans read by TKreadScan are a "set". For single swath data, one scan is read so NumberScansInSet=1. For multiple swath data, one TKreadScan may read more than one scan. For example, for SSM/I data one TKreadScan reads one low frequency scan and two high frequency scans. Therefore NumberScansInSet=1 for the low frequency swath and Number-ScansInSet=2 for the high frequency swath.	50
2	MaximumNumberScansTotal	The maximum allowed number of total scans in this swath. Total scans = overlap scans before granule + scans in granule + overlap scans after granule.	50
3	NumberScansBeforeGranule	The number of overlap scans before the first scan of the granule in this swath.	50
4	NumberScansGranule	The number of scans in the granule in this swath.	50
5	NumberScansAfterGranule	The number of overlap scans after the last scan of the granule in this swath.	50
6	NumberPixels	The number of IFOV in each scan in this swath.	50
7	ScanType	The type of scan in this swath. Values are: "CROSSTRACK" and "CONICAL".	50

2.2 Data Group

Elements of data group are explained in detail in this section. Each swath has 9 data group and 2 data (Latitude and Longitude) commonly. Figure 2.2-1 shows data group structure.

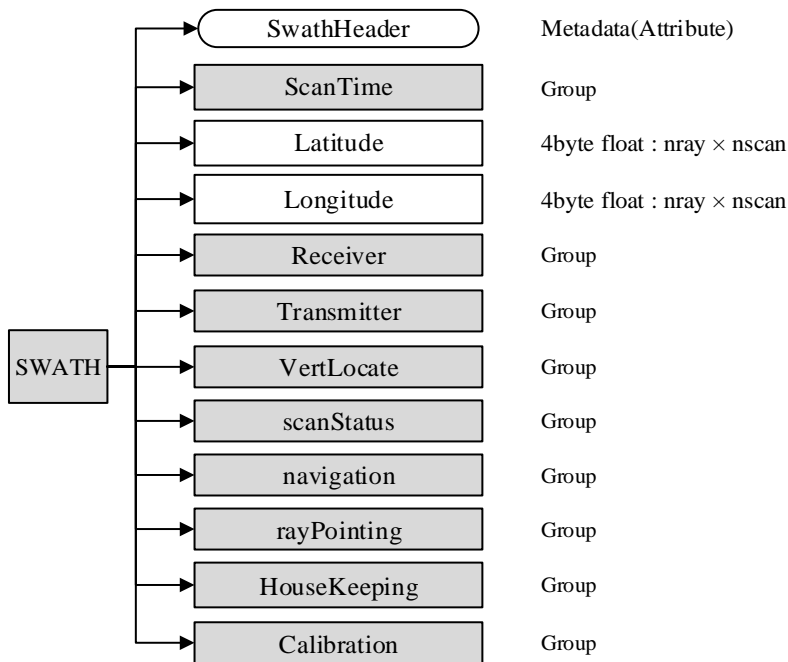

Figure2.2-1 Data Format Structure for Data Group

2.2.1 ScanTime (Group)

(1) Year

Type	Array	Unit
2-byte integer	nscan	year

4-digit year, e.g., 2014. Values range from 1950 to 2100 years.

Missing value:

N/A

(2) Month

Type	Array	Unit
1-byte integer	nscan	month

Month of the year. Values range from 1 to 12 months.

Missing value:

N/A

(3) DayOfMonth

Type	Array	Unit
1-byte integer	nscan	day

Day of the month. Values range from 1 to 31 days.

Missing value:

N/A

(4) Hour

Type	Array	Unit
1-byte integer	nscan	hour

UTC hour of the day. Values range from 0 to 23 hours.

Missing value:

N/A

(5) Minute

Type	Array	Unit
1-byte integer	nscan	minute

Minute of the hour. Values range from 0 to 59 minutes.

Missing value:

N/A

(6) Second

Type	Array	Unit
1-byte integer	nscan	s

Second of the minute. Values range from 0 to 60 s.

Missing value:

N/A

(7) MilliSecond

Type	Array	Unit
2-byte integer	nscan	ms

Thousandths of the second. Values range from 0 to 999 ms.

Missing value:

N/A

(8) DayOfYear

Type	Array	Unit
2-byte integer	nscan	day

Day of the year. Values range from 1 to 366 days.

Missing value:

N/A

(9) SecondOfDay

Type	Array	Unit
8-byte float	nscan	s

A time associated with the scan. It is expressed as the UTC seconds of the day. Values range from 0 to 86400 s.

Missing value:

N/A

2.2.2 Latitude

(1) Latitude

Type	Array	Unit
4-byte float	nray * nscan	degrees

The earth latitude of the center of the IFOV at the altitude of the earth ellipsoid. Latitude is positive north, negative south. Values range from -90 to 90 degrees.

Missing value:

-9999.9

2.2.3 Longitude

(1) Longitude

Type	Array	Unit
4-byte float	nray * nscan	degrees

The earth longitude of the center of the IFOV at the altitude of the earth ellipsoid. Longitude is positive east, negative west. A point on the 180th meridian has the value -180 degrees. Values range from -180 to 180 degrees.

Missing value:

-9999.9

2.2.4 Receiver (Group)

(1) echoPower

Type	Array	Unit
2-byte integer	nbin * nray * nscan	0.01 dBm

It is received power, which is multiplied by 100. Bins where data is not written due to a transmission, calibration, or other problem, including an entire scan of missing bins, have the value of -30000. Outrange bins of the observation area controlled by VPRF tables have the value of -29999. The range is -120 dBm to -20 dBm, which corresponds to values in the file from -12000 to -2000.

Missing values:

“Count value”: internal calibration mode.

-29999 : Outrange bins of the observation area.

-30000 : missing value.

(2) echoCount

Type	Array	Unit
1-byte integer	nbin * nray * nscan	N/A

The total signal count at the antenna input that includes both echo and noise power. The signal count is stored on both observation mode and calibration mode. It is basically a copy of science telemetry raw data for sampling range bins. 0 is set to both interpolated range bin and outrange bin of the observation mode.

Missing values:

0: at missing scan, thinning out range (normal sample) and out of observation range.

(3) noisePower

Type	Array	Unit
2-byte integer	nray * nscan	0.01 dBm

An average of the received noise power for each angle bins during suspended 4 pulses. The range is -120 dBm to -20 dBm which corresponds to values in the file from -12000 to -2000.

Missing value:

-30000 : at missing scan and internal calibration mode.

(4) noiseCount

Type	Array	Unit
4-byte float	nray * nscan	N/A

An average of the received noise count for each angle bins during suspended 4 pulses.

Missing value:

-9999.9 : at missing scan and internal calibration mode.

(5) noiseSampleNumber

Type	Array	Unit
2-byte integer	nray * nscan	number

It is the number of noise samplings defined by VPRF table. Values range from 0 to 140 Number.

Missing value:

-9999 : at missing scan and internal calibration mode.

(6) echoSampleNumber

Type	Array	Unit
1-byte integer	nray * nscan	number

It is the number of received pulse defined by VPRF table. Values range from 0 to 60 Number.

Missing value:

48 : at internal calibration mode.

-99 : at missing scan.

(7) rxAntGain

Type	Array	Unit
4-byte float	nray * nscan	dB

Received radar antenna effectiveness.

Missing value:

-9999.9 : at missing scan and internal calibration mode.

(8) receivedPulseWidth

Type	Array	Unit
4-byte float	nscan	s

Received pulse width (s) after passing through band pass filter of FCIF.

Missing value:

-9999.9 : at missing scan and internal calibration mode.

2.2.5 Transmitter (Group)**(1) radarTransPower**

Type	Array	Unit
4-byte float	nscan	dBm

The total (sum) power of 128 SSPA elements corrected with SSPA temperature in orbit. It is based on ground test temperature data of SSPA transmission power.

Missing value:

-9999.9 : at missing scan and internal calibration mode.

(2) transPulseWidth

Type	Array	Unit
4-byte float	nscan	s

Transmitted pulse width corrected with FCIF temperature in orbit, based on temperature test data of

2.2 Data Group

2.2.5 Transmitter (Group)

FCIF. Values range from 0.0000015 to 0.0000017 s.

Missing value:

-9999.9 : at missing scan and internal calibration mode.

(3) txAntGain

Type	Array	Unit
4-byte float	nray* nscan	dB

Transmitted radar antenna effectiveness (dB).

Missing value:

-9999.9 : at missing scan and internal calibration mode.

2.2.6 VertLocate (Group)**(1) landOceanFlag**

Type	Array	Unit
2-byte integer	nray * nscan	N/A

Land or ocean information. The values of the flag are:

0 : Ocean
1 : Land
2 : Coast
3 : Inland water

Missing value:

-9999 : Land or Ocean Database is missing.

(2) scLocalZenith

Type	Array	Unit
4-byte float	nray * nscan	degrees

The angle, in degrees, between the local zenith and the beam's center line. The local (geodetic) zenith at the intersection of the ray and the earth ellipsoid is used. Values range from 0 to 90 degrees.

Missing value:

-9999.9

(3) startBinRange

Type	Array	Unit
4-byte float	nray * nscan	m

It is the distance from the satellite to the center of the first range bin. Values range from 350000 to 500000 m.

Missing value:

-9999 : at missing scan and internal calibration mode.

(4) echoHighResBinNumber

Type	Array	Unit
2-byte integer	nray * nscan	range bin

It is the number of sampling without thinning out (over sampling). Values range from 1 to 260 range bin number at NS and MS while from 1 to 130 at HS.

Missing values :

-9999 : at missing scan.

42 : at internal calibration mode.

(5) echoLowResBinNumber

Type	Array	Unit
2-byte integer	nray * nscan	range bin

It is the number of sampling with thinning out (normal sample). Values range from 1 to 260 range bin number at NS and MS while from 1 to 130 at HS.

Missing value:

-9999 : at missing scan and internal calibration mode.

(6) binEllipsoid

Type	Array	Unit
2-byte integer	nray * nscan	range bin

The range bin number of the earth ellipsoid. Values range from 1 to 260 range bin number at NS and MS, from 1 to 130 at HS.

Missing value:

-9999 : at missing scan and internal calibration mode.

(7) scRangeEllipsoid

Type	Array	Unit
4-byte float	nray * nscan	m

It is the distance from instrument to ellipsoid calculated by GeoTK.

Missing value:

-9999.9

(8) binDEM

Type	Array	Unit
2-byte integer	nray * nscan	range bin

The range bin number of the average DEM surface elevation in a box centered on the IFOV. Reference width is 5 km x 5 km. Reference number of pixels in the direction of latitude is 7. On the other hand, the number of pixels in the direction of longitude reference is changed to 21-7 by latitude. Values range from 1 to 260 range bin number at NS and MS while from 1 to 130 at HS.

Missing value:

-9999 : at missing scan and internal calibration mode and in case DEM is missing.

(9) scRangeDEM

Type	Array	Unit
4-byte float	nray * nscan	m

It is calculated by the following equation:

$$\text{scRangeDEM} = \text{scRangeEllipsoid} - \text{DEMHmean} \times \sec(\text{localZenithAngle}).$$

Missing value:

-9999.9

(10) DEMHmean

Type	Array	Unit
2-byte integer	nray * nscan	m

DEMHmean is defined as averaged DEM height, whose SRTM-30, in each ray. Values range from 0 to 9000 m.

Missing value:

-9999.9 : DEM is missing

(11) binDEMHtop

Type	Array	Unit
2-byte integer	nray * nscan	range bin

The range bin number of the maximum DEM surface elevation in a box centered on the IFOV. Reference width is 5 km x 5 km. Reference number of pixels in the direction of latitude is 7. On the other hand, the number of pixels in the direction of longitude reference is changed to 21-7 by latitude. Values range from 1 to 260 range bin number at NS and MS, from 1 to 130 at HS.

Missing value:

-9999 : at missing scan and internal calibration mode and in case DEM is missing.

(12) binDEMbottom

Type	Array	Unit
2-byte integer	nray * nscan	range bin

The range bin number of the minimum DEM surface elevation in a box centered on the IFOV. Reference width is 5 km x 5 km. Reference number of pixels in the direction of latitude is 7. On the other hand, the number of pixels in the direction of longitude reference is changed to 21-7 by latitude. Values range from 1 to 260 range bin number at NS and MS, from 1 to 130 at HS.

Missing value:

-9999 : at missing scan and internal calibration mode and in case DEM is missing.

(13) binEchoPeak

Type	Array	Unit
2-byte integer	nray * nscan	range bin

It is the range bin number which has maximum echoPower in each scan and each angle bin. Values range from 1 to 260 range bin number at NS and MS, from 1 to 130 at HS.

Missing value:

-9999 : at missing scan and internal calibration mode.

(14) alongTrackBeamWidth

Type	Array	Unit
4-byte float	nray * nscan	degrees

Radar beamwidth (degree) at the point transmitted power reaches one half of peak power in the along-track direction.

Missing value:

N/A

(15) crossTrackBeamWidth

Type	Array	Unit
4-byte float	nray * nscan	degrees

Radar beamwidth (degree) at the point transmitted power reaches one half of peak power along the cross-track direction.

Missing value:

N/A

(16) mainlobeEdge

Type	Array	Unit
2-byte integer	nray * nscan	range bin

Absolute distance in range bin numbers between the detected surface and the upper edge of the clutter from the mainlobe.

Missing value:

N/A

(17) sidelobeRange

Type	Array	Unit
2-byte integer	nray * nscan	range bin

Absolute distance in range bin numbers between the detected surface and the upper clutter position from the sidelobe.

Missing value:

N/A

(18) ellipsoidBinOffset

Type	Array	Unit
4-byte float	nray * nscan	m

It is the distance between center of binEllipsoid range bin and Ellipsoid position.

Missing value:

-9999.9 : at missing scan and internal calibration mode.

(19) rangeBinSize

Type	Array	Unit
4-byte float	nscan	m

It is range bin size. The values are

<DPR>		
with VPRF	NS, MS	→ 125.16335(m)
	HS	→ 250.32670(m)
with limited PRF	NS, MS, HS	→ 250.32670 (m)
<PR>		
	NS	→ 124.9968 (m)

Missing value:

-9999.9 : at missing scan and internal calibration mode.

(20) ratioLand

Type	Array	Unit
1-byte integer	nray * nscan	percent

It is percentage of land area in one footprint. Values range from 0 to 100 %.

Missing value:

-99

(21) ratioOcean

Type	Array	Unit
1-byte integer	nray * nscan	percent

It is percentage of ocean area in one footprint. Values range from 0 to 100 %.

Missing value:

-99

(22) ratioInLand

Type	Array	Unit
1-byte integer	nray * nscan	percent

It is percentage of inland area in one footprint. Values range from 0 to 100 %.

Missing value:

-99

(23) ratioCoast

Type	Array	Unit
1-byte integer	nray * nscan	percent

It is percentage of coast area in one footprint. Values range from 0 to 100 %.

Missing value:

-99

2.2.7 scanStatus (Group)

(1) dataQuality

Type	Array	Unit
1-byte integer	nscan	N/A

A summary of data quality in the scan. Unless this is 0 (normal), the scan data is meaningless to higher precipitation processing. Bit 0 is the least significant bit (i.e., if bit $i = 1$ and other bits = 0, the unsigned integer value is 2^{**i}).

Bit Meaning

0 : missing

5 : geoError is not zero

6 : modeStatus is not zero

(2) dataWarning

Type	Array	Unit
1-byte integer	nscan	N/A

Flag of data warning for each scan. Bit Meaning is below.

Bit Meaning

0 : beam Matching is abnormal

1 : VPRF table is abnormal

2 : surface Table is abnormal

3 : geoWarning is not Zero

4 : operational mode is not observation mode.

5 : GPS status is abnormal

(3) missing

Type	Array	Unit
1-byte integer	nscan	N/A

Indicates whether information is contained in the scan data. The values are:

Bit Meaning

- 0 : Scan is missing
- 1 : Science telemetry packet missing
- 2 : Science telemetry segment withing packet missing
- 3 : Science telemetry other missing
- 4 : Housekeeping (HK) telemetry packet missing
- 5 : Spare (always 0)
- 6 : Spare (always 0)
- 7 : Spare (always 0)

(4) modeStatus

Type	Array	Unit
1-byte integer	nscan	N/A

A summary of status modes. If all status modes are routine, all bits in modeStatus = 0. Routine means that scan data has been measured in the normal operational situation as far as the status modes are concerned. modeStatus does not assess geolocation quality. modeStatus is broken into 8 bit flags. Each bit = 0 if the status is routine but the bit = 1 if the status is not routine. Bit 0 is the least significant bit (i.e., if bit $i = 1$ and other bits = 0, the unsigned integer value is 2^{*i}). The non-routine situations follow:

Bit Meaning

- 0 : Spare (always 0)
- 1 : SCorientation not 0 or 180
- 2: pointingStatus not 0
- 3 : Non-routine limitErrorFlag
- 4 : Non-routine operationalMode (not 1 or 11)
- 5 : Spare (always 0)
- 6 : Spare (always 0)
- 7 : Spare (always 0)

(5) geoError

Type	Array	Unit
2-byte integer	nscan	N/A

A summary of geolocation errors in the scan. geoError is used to set a bit in dataQuality. A zero integer value of geoError indicates 'good' geolocation. A non-zero value broken down into the bit flags below indicates the specified reason, where bit 0 is the least significant bit (i.e., if bit $i = 1$ and other bits = 0 the unsigned integer value is 2^{**i}). Bits 0, 4, 5, 8 and 9 are per pixel error flags. If the number of bad pixels (for any of the reasons specified by these flags) is greater than the threshold then bit 7 = 1 and each of these flags is set to 1 if any pixel is bad for that reason. At launch this threshold is zero, so data is flagged if any pixel is bad. If the number of bad pixels is less than or equal to the threshold then bit 7 = 0 and all of these flags are also 0.

Bit Meaning

- 0 : Latitude limit exceeded for viewed pixel locations
- 1 : Negative scan time, invalid input
- 2 : Error getting spacecraft attitude at scan mid-time
- 3 : Error getting spacecraft ephemeris at scan mid-time
- 4 : Invalid input non-unit ray vector for any pixel
- 5 : Ray misses Earth for any pixel with normal pointing
- 6 : Nadir calculation error for subsatellite position
- 7 : Pixel count with geolocation error over threshold
- 8 : Error in getting spacecraft attitude for any pixel
- 9 : Error in getting spacecraft ephemeris for any pixel
- 10 : Spare (always 0)
- 11 : Spare (always 0)
- 12 : Spare (always 0)
- 13 : Spare (always 0)
- 14 : Spare (always 0)
- 15 : Spare (always 0)

(6) geoWarning

Type	Array	Unit
2-byte integer	nscan	N/A

A summary of geolocation warnings in the scan. geoWarning does not set a bit in dataQuality. Warnings indicate unusual conditions. These conditions do not indicate bad geolocation but are flagged as a warning that further review of the data may be useful. A zero integer value indicates usual geolocation. A non-zero value broken down into the following bit flags indicates the following, where bit 0 is the least significant bit (i.e., if bit $i = 1$ and other bits = 0 the unsigned integer value is 2^{**i}):

Bit Meaning

- 0 : Ephemeris Gap Interpolated
- 1 : Attitude Gap Interpolated
- 2 : Attitude jump/discontinuity
- 3 : Attitude out of range
- 4 : Anomalous Time Step
- 5 : GHA not calculated due to error
- 6 : SunData (Group) not calculated due to error
- 7 : Failure to calculate Sun in inertial coordinates
- 8 : Fallback to GES ephemeris
- 9 : Fallback to GEONS ephemeris
- 10 : Fallback to PVT ephemeris
- 11 : Fallback to OBP ephemeris
- 12 : Spare (always 0)
- 13 : Spare (always 0)
- 14 : Spare (always 0)
- 15 : Spare (always 0)

(7) Sorientation

Type	Array	Unit
2-byte integer	nscan	degrees

The positive angle of the spacecraft vector (v) from the satellite forward direction of motion, measured clockwise facing down. We define v in the same direction as the spacecraft axis +X, which is also the center of the GMI scan. If Sorientation is not 0 or 180, a bit is set to 1 in modeStatus.

Value Meaning

0 : +X forward (yaw 0)

180 : -X forward (yaw 180)

-8000 : Non-nominal pointing

-9999 : Missing

(8) pointingStatus

Type	Array	Unit
2-byte integer	nscan	N/A

It is provided by the GeoTK. A value of zero means the pointing is good. Non-zero values indicate non-nominal pointing. If pointingStatus is non-zero, a bit in modeStatus is set to 1.

Value Meaning

0 : Nominal pointing in Mission Science Mode

1 : GPS point solution stale and PVT ephemeris used

2 : GEONS solution stale and GEONS ephemeris used

-8000 : Non-nominal mission science orientation

-9999 : Missing

(9) acsModeMidScan

Type	Array	Unit
1-byte integer	nscan	N/A

It is provided by the GeoTK as taken from Attitude Control System telemetry and is provided in this format for information only.

Value Meaning
0 : LAUNCH
1 : RATENULL
2 : SUNPOINT
3 : GSPM (Gyro-less Sun Point)
4 : MSM (Mission Science Mode)
5 : SLEW
6 : DELTAH
7 : DELTAV

(10) targetSelectionMidScan

Type	Array	Unit
1-byte integer	nscan	N/A

It is provided by the GeoTK as taken from Attitude Control System telemetry and is provided in this format for information only.

Value Meaning
0 : S/C Z axis nadir, +X in flight direction
1 : Flight Z axis nadir, +X in flight direction
2 : S/C Z axis nadir, -X in flight direction
3 : Flight Z axis nadir, -X in flight direction
4 : +90 yaw for DPR antenna pattern calibration
5 : -90 yaw for DPR antenna pattern calibration
-99 : Missing
Other standard target orientations TBD

(11) operationalMode

Type	Array	Unit
1-byte integer	nscan	N/A

The operational mode of KuPR/KaPR/PR stored in science telemetry basically. However, if science telemetry is not made like as stand-by mode, KuPR/KaPR L1B algorithm decides it using HK telemetry. PR L1B algorithm stored missing value. The values range is 1 to 20 for KuPR/KaPR. The values range is 1 to 3, 5, 6, 10, -99. The value meaning is shown below.

Value Meaning

- 1 : Ku/Ka/PR Observation
- 2 : Ku/Ka/PR External Calibration
- 3 : Ku/Ka/PR Internal Calibration
- 4 : Ku/Ka SSPA Analysis
- 5 : Ku/Ka/PR LNA Analysis
- 6 : Ku/Ka/PR Health-Check
- 7 : Ku/Ka Standby VPRF Table OUT
- 8 : Ku/Ka Standby Phase Out
- 9 : Ku/Ka Standby Dump Out
- 10 : Ku/Ka Standby (No Science Data)
- 11 : Ku/Ka/PR Independent Observation
- 12 : Ku/Ka Independent External Calibration
- 13 : Ku/Ka Independent Internal Calibration
- 14 : Ku/Ka Independent SSPA Analysis
- 15 : Ku/Ka Independent LNA Analysis
- 16 : Ku/Ka Independent Health-Check
- 17 : Ku/Ka Independent Standby VPRF Table OUT
- 18 : Ku/Ka Independent Standby Phase Out
- 19 : Ku/Ka Independent Standby Dump Out
- 20 : Ku/Ka Independent Standby (No Science Data)
- 99 : PR missing value (No Science Data)

(12) limitErrorFlag

Type	Array	Unit
1-byte integer	nscan	N/A

It has 2 error information. One is as for noise power limit, another one is as for binEllipsoid limit. The former is defined that if there are more than 2 overlimited rays in a swath, limitErrorFlag(at 0bit) is adapted. On the other hand, the later is defined that if there is even an overlimited ray, limitErrorFlag(at 1bit) is adapted. Then, LimitErrorFlag is used in modeStatus, dataQuality in scanStatus Group picks it up consequently.

The values are

Bit Meaning
0 : noise power limit error
1 : binEllipsoid is missing
2 : Spare (always 0)
3 : Spare (always 0)
4 : Spare (always 0)
5 : Spare (always 0)
6 : Spare (always 0)
7 : Spare (always 0)

(13) FractionalGranuleNumber

Type	Array	Unit
8-byte float	nscan	N/A

The floating point granule number. The granule begins at the Southern-most point of the spacecraft's trajectory. For example, FractionalGranuleNumber = 10.5 means the spacecraft is halfway through granule 10 and starting the descending half of the granule. Values range from 0 to 100000. In Near Real Time (NRT) process, granule number is stored only '0', so Fractional Granule Number less than 1.0.

Missing value:

N/A

2.2.8 navigation (Group)

(1) scPos

Type	Array	Unit
4-byte float	XYZ * nscan	m

The position vector(m) of the spacecraft in Earth-Centered Earth Fixed (ECEF) Coordinates at the Scan mid-Time (i.e., time at the middle pixel/IFOV of the active scan period). Values range from -10000000 to 10000000 m.

Missing value:

-9999.9

(2) scVel

Type	Array	Unit
4-byte float	XYZ * nscan	m/s

The velocity vector (m/s) of the spacecraft in ECEF Coordinates at the Scan mid-Time. Values range from -10000000 to 10000000 m/s.

Missing value:

-9999.9

(3) scLat

Type	Array	Unit
4-byte float	nscan	degrees

The geodesic latitude (decimal degrees) of the spacecraft at the Scan mid-Time. Values range from -70 to 70 degrees.

Missing value:

-9999.9

(4) scLon

Type	Array	Unit
4-byte float	nscan	degrees

The geodesic longitude (decimal degrees) of the spacecraft at the Scan mid-Time. Values range from -180 to 180 degrees.

Missing value:

-9999.9

(5) scAlt

Type	Array	Unit
4-byte float	scan	m

The altitude (m) of the spacecraft above the Earth Ellipsoid at the Scan mid-Time. It is computed by GeoTK. Values range from 350000 to 500000 m.

Missing value:

-9999.9

(6) dprAlt

Type	Array	Unit
4-byte float	nscan	m

The altitude (m) of the spacecraft above the Earth Ellipsoid at the Scan mid-Time from DPR science telemetry. This is empty in non-DPR products. It is stored 'GPS Altitude Data' with LSB equal to 10m in DPR science telemetry. Values range from 350000 to 500000 m.

Missing value:

-9999.9 : at missing scan and internal calibration mode.

(7) scAttRollGeoc

Type	Array	Unit
4-byte float	nscan	degrees

The geocentric satellite attitude Euler roll angle (degrees) at the Scan mid-Time. The order of the components in the file is roll, pitch, and yaw. However, the angles are computed using a 3-2-1 Euler rotation sequence representing the rotation order yaw, pitch, and roll for the rotation from Orbital Coordinates to the spacecraft body coordinates. Orbital Coordinates represent an orthogonal triad in Geocentric Inertial Coordinates where the Z-axis is toward the geocentric nadir, the Y-axis is perpendicular to the spacecraft velocity opposite the orbit normal direction, and the X-axis is approximately in the velocity direction for a near circular orbit. Note this is geocentric, not geodetic, referenced, so that pitch and roll will have twice orbital frequency components due to the onboard control system following the oblate geodetic Earth horizon. Note also that the yaw value will show an orbital frequency component relative to the Earth fixed ground track due to the Earth rotation relative to inertial coordinates. Values range from -180 to 180 degrees.

Missing value:

-9999.9

(8) scAttPitchGeoc

Type	Array	Unit
4-byte float	nscan	degrees

The geocentric satellite attitude Euler pitch angle (degrees) at the Scan mid-Time. Values range from -180 to 180 degrees.

Missing value:

-9999.9

(9) scAttYawGeoc

Type	Array	Unit
4-byte float	nscan	degrees

The geocentric satellite attitude Euler yaw angle (degrees) at the Scan mid-Time. Values range from -135 to 225 degrees.

Missing value:

-9999.9

(10) scAttRollGeod

Type	Array	Unit
4-byte float	nscan	degrees

The geodetic satellite attitude Euler roll angle (degrees) at the Scan mid-Time. The order of the components in the file is roll, pitch, and yaw. However, the angles are computed using a 3-2-1 Euler rotation sequence representing the rotation order yaw, pitch, and roll for the rotation from Geodetic Coordinates to the spacecraft body coordinates. Geodetic Coordinates represent an orthogonal triad in Geocentric Inertial Coordinates where the Z-axis is toward the geodetic nadir, the Y-axis is perpendicular to the spacecraft velocity opposite the orbit normal direction, and the X-axis is approximately in the velocity direction for a near circular orbit. Values range from -180 to 180 degrees.

Missing value:

-9999.9

(11) scAttPitchGeod

Type	Array	Unit
4-byte float	nscan	degrees

The geodetic satellite attitude Euler pitch angle (degrees) at the Scan mid-Time. Values range from -180 to 180 degrees.

Missing value:

-9999.9

(12) scAttYawGeod

Type	Array	Unit
4-byte float	nscan	degrees

The geodetic satellite attitude Euler yaw angle (degrees) at the Scan mid-Time. Values range from -135 to 225 degrees.

Missing value:

-9999.9

(13) greenHourAng

Type	Array	Unit
4-byte float	nscan	degrees

The rotation angle (degrees) from Geocentric Inertial Coordinates to Earth Fixed Coordinates. Values range from 0 to 390 degrees.

Missing value:

-9999.9

(14) timeMidScan

Type	Array	Unit
8-byte float	nscan	s

The Scan mid-Time in GPS Atomic time, namely the seconds since 0000 UTC, 6 Jan 1980. timeMidScan is used as the reference time for the scPos and scVel values. Values range from 0 to 10000000000 s.

Missing value:

-9999.9

(15) timeMidScanOffset

Type	Array	Unit
8-byte float	nscan	s

Offset from the secondary header packet time to the timeMidScan. Values range from 0 to 100 s.

Missing value:

-9999.9

2.2.9 rayPointing (Group)**(1) rayDirectionX**

Type	Array	Unit
4-byte float	nray * nscan	N/A

Unit ray direction x component in mechanical coordinates. Values range from -1.0 to 1.0.

Missing value:

N/A

(2) rayDirectionY

Type	Array	Unit
4-byte float	nray * nscan	N/A

Unit ray direction y component in mechanical coordinates. Values range from -1.0 to 1.0.

Missing value:

N/A

(3) instrumentYaw

Type	Array	Unit
4-byte float	nray * nscan	degrees

Yaw of mechanical coordinates with reference to geodetic coordinates. Values range from -135 to 225 degrees.

Missing value:

-9999.9

(4) instrumentPitch

Type	Array	Unit
4-byte float	nray * nscan	degrees

Pitch of mechanical coordinates with reference to geodetic coordinates. Values range from -90 to 90 degrees.

Missing value:

-9999.9

(5) instrumentRoll

Type	Array	Unit
4-byte float	nray * nscan	degrees

Roll of mechanical coordinates with reference to geodetic coordinates. Values range from -180 to 180 degrees.

Missing value:

-9999.9

(6) rayTiming

Type	Array	Unit
4-byte float	nray * nscan	s

The time delay from the secondary header packet time tag to each ray (assumed as midtime of all radar pulses for the associated rayDirection). Values range from 0 to 1.6 s.

Missing value:

N/A

(7) scanAngle

Type	Array	Unit
4-byte float	nray * nscan	degrees

Angle (degrees) of the ray from nominal nadir offset about the mechanical x axis. The sign of the angle is consistent with the sensor y-axis, i.e., the angle is positive to the right of the direction of travel if the spacecraft is in normal mode.

Missing value:

N/A

2.2.10 HouseKeeping (Group)**(1) rxAtt**

Type	Array	Unit
1-byte integer	nscan	dB

Attenuator setting levels of Received radar antenna. Values are 0, 3, 6, 9 and 12 in dB.

Missing value

-99 : at missing scan and internal calibration mode.

(2) rxAttGainOffset

Type	Array	Unit
4-byte float	nscan	dB

It is the actual gain of rxAtt considering the temperature dependence.

Missing value:

-9999.9: missing scan and internal calibration mode.

(3) binDiffPeakDEM

Type	Array	Unit
4-byte float	nray * nscan	range bin

It is the number of difference for range bin between “binEchoPeak” and “binDEM”. It is used to ensure that the VPRF is switched in accordance with the GPM satellite altitude. Values range from -260 to 260 range bin number at NS and MS, from -130 to 130 range bin number at HS respectively.

Missing value:

-9999 : at missing scan and internal calibration mode.

(4) scTime

Type	Array	Unit
8-byte float	nscan	N/A

It is expressed as TAI time with epoch of 0000Z Jan 6, 1980. This time is space craft clock time for N scan in secondary header.

Missing value:

N/A

(5) vprfTableVersion

Type	Array	Unit
1-byte integer	nscan	number

It is the version number of VPRF table which is used in L1B process.

Missing value:

-99 : at missing scan and internal calibration mode.

(6) vprfTableSelect

Type	Array	Unit
1-byte integer	nscan	number

vprfTableSelect is the selected number of VPRF table for altitude which is used in L1B process. The range is 1 to 25.

Missing value:

-99 : at missing scan and internal calibration mode.

Table 2.2.10-1 Relation between satellite altitude and VPRFTableSelect.

satellite altitude (km)	vprfTableSelect
under 396.5	1
396.5 ~ under 397.5	2
397.5 ~ under 398.5	3
398.5 ~ under 399.5	4
399.5 ~ under 400.5	5
400.5 ~ under 401.5	6
401.5 ~ under 402.5	7
402.5 ~ under 403.5	8
403.5 ~ under 404.5	9
404.5 ~ under 405.5	10
405.5 ~ under 406.5	11
406.5 ~ under 407.5	12
407.5 ~ under 408.5	13
408.5 ~ under 409.5	14
409.5 ~ under 410.5	15
410.5 ~ under 411.5	16
411.5 ~ under 412.5	17
412.5 ~ under 413.5	18
413.5 ~ under 414.5	19
414.5 ~ under 415.5	20
415.5 ~ under 416.5	21
416.5 ~ under 417.5	22
417.5 ~ under 418.5	23
418.5 ~ under 419.5	24
419.5 and over	25

(7) catchingInt

Type	Array	Unit
1-byte integer	nscan	number

The timing that receive window is open for the first reflected TX pulse. If catchingInt is set “12”, then the first TX pulse is received with receive window after the 12th TX pulse.

In the case of nominal operation, catchingInt is adapted “12”, that is, VPRF table is adapted. Another case, which may be GPS Status trouble situation, it is set “8” and limited PRF is loaded.

Missing values are defined as:

-99 at missing scan and internal calibration mode.

(8) scdpFlag

Type	Array	Unit
1-byte signed char	nscan	N/A

scdpFlag shows the flag information of A side or B side of the system control/data processing (SCDP) system.

Bit Meaning

0 : 0 : SCDP A-side, 1:SCDP B-side

1 : Priority is 1 at Basic System Table. Refer to Basic System Table.

2 : Priority is 2 at Basic System Table. Refer to HK telemetry.

3 : Priority is 2 at Basic System Table. Refer to Basic System Table.

4 : (spare)

5 : (spare)

6 : (spare)

7 : (spare)

(9) fcifFlag

Type	Array	Unit
1-byte signed char	nscan	N/A

It shows side of FCIF system and resource of its decision.

Bit Meaning
0 : 0 : FCIF A-side, 1:FCIF B-side
1 : Priority is 1 at Basic System Table. Refer to Basic System Table.
2 : Priority is 2 at Basic System Table. Refer to HK telemetry
3 : Priority is 2 at Basic System Table. Refer to Basic System Table
4 : (spare)
5 : (spare)
6 : (spare)
7 : (spare)

- Basic System Table : This table defines the basic system information which consists of FCIF, SCDP, SCDP independent Flag, and priority.
- Priority : 1 = Refers only to Basic System Table.
2 = Refers to HK telemetry; if the telemetry is missing, refers to Basic System Table.

(10) logAmpNoiseLevel

Type	Array	Unit
2-byte integer	nscan	count

It is the Noise Level at Log Amp Termination which is stored in science telemetry.

Missing value:

-9999 : at missing scan and internal calibration mode.

(11) delay

Type	Array	Unit
2-byte integer	nscan	number

It is the timing offset value from space craft time in NS. In MS and HS, it is defined as offset time value from the base delay time. They are used to adjust for beam matching of along track direction. Values range from 0 to 3360 Number.

Missing value:

N/A

(12) seqCountL1A

Type	Array	Unit
2-byte integer	nscan	count

It is the scan number which is determined by the L1A product. Values range from 1 to 27000 counts.

Missing value:

-9999

(13) fcifTemp

Type	Array	Unit
2-byte integer	2 * nscan	0.01C

The temperature of FCIF component, which is averaged during about 3 minutes. The first dimension is temperature and the other is the number of referenced HK telemetry. Temperature values are multiplied by 100 and stored as a 2 byte integer. The range is -50C to 50C which correspond to values from -5000 to 5000.

Missing value:

-9999

(14) lnaTemp

Type	Array	Unit
2-byte integer	2 * nscan	0.01C

The temperature of LNA component, which is averaged during about 3 minutes. The first dimension is temperature and the other is the number of referenced HK telemetry. Temperature values are multiplied by 100 and stored as a 2 byte integer. The range is -50C to 50C which corresponds to values from -5000 to 5000.

Missing value:

-9999

(15) rdaTemp

Type	Array	Unit
2-byte integer	2 * nscan	0.01C

The temperature of RDA component, which is averaged during about 3 minutes. The first dimension is temperature and the other is the number of referenced HK telemetry. Temperature values are multiplied by 100 and stored as a 2 byte integer. The range is -50C to 50C which correspond to values from -5000 to 5000.

Missing value:

-9999

(16) divcomb1Temp

Type	Array	Unit
2-byte integer	2 * nscan	0.01C

The temperature of divcomb1, which is averaged during about 3 minutes. The first dimension is temperature and the other is the number of referenced HK telemetry. Temperature values are multiplied by 100 and stored as a 2 byte integer. The range is -50C to 50C which correspond to values from -5000 to 5000.

Missing value:

-9999

(17) divcomb2Temp

Type	Array	Unit
2-byte integer	2 * nscan	0.01C

The temperature of divcomb2, which is averaged during about 3 minutes. The first dimension is temperature and the other is the number of referenced HK telemetry. Temperature values are multiplied by 100 and stored as a 2 byte integer. The range is -50C to 50C which correspond to values from -5000 to 5000.

Missing value:

-9999

(18) sspaTemp

Type	Array	Unit
2-byte integer	2 * nscan	0.01C

The temperature of RDA component, which is averaged during about 3 minutes. The first dimension is temperature and the other is the number of referenced HK telemetry. Temperature values are multiplied by 100 and stored as a 2 byte integer. The range is -50C to 50C which correspond to values from -5000 to 5000.

Missing value:

-9999

(19) rxGain

Type	Array	Unit
4-byte float	nray*nscan	dB

The total receiver gain from FCIF input to antenna input.

Missing value:

-9999.9 : at missing scan and internal calibration mode.

(20) scdpFlagAB

Type	Array	Unit
1-byte integer	nscan	N/A

The scdpFlagAB includes information for flag of the SCDP A or SCPD B only.

-99: missing

<p>Bit Meaning</p> <p>0: SCDP A side is selected.</p> <p>1: SCDP B side is selected.</p>
--

(21) fcifFlagAB

Type	Array	Unit
1-byte integer	nscan	N/A

The fcifFlagAB includes information for flag of the FCIF A or FCIF B only.

-99: missing

<p>The values of the flag are:</p> <p>0 : FCIF A side is selected.</p> <p>1: FCIF B side is selected.</p>

2.2.11 Calibration (Group)

(1) fcifInPower

Type	Array	Unit
2-byte integer	nscan	0.01 dBm

It is input power value of FCIF and is set at internal calibration mode. At another mode, the value of fcifInPower is set as missing.

Missing value:

-30000: except internal calibration mode.

(2) intAttSelect

Type	Array	Unit
1-byte integer	nscan	step

It is the selected number of internal attenuation that is controlled automatically with 32 steps and is set by internal mode. At another mode, the value of fcifInPower is set as missing. Values range from 1 to 32 Number.

Missing value:

-99 : except internal calibration mode.

(3) sspaLnaSelect

Type	Array	Unit
2-byte integer	nscan	number

In the case of SSPA mode, it is stored number of LNA. On the other hand, in the case of LNA mode, it is stored the number of SSPA. At the other modes, missing value is stored. Values range from 1 to 128 Number.

Missing value:

-9999 : except SSPA and LNA analysis mode.

(4) angleBinSelect

Type	Array	Unit
1-byte integer	nscan	number

It is the selected beam number used SSPA and LNA analysis mode. In case of another operational mode, the value of angleBinSelect is set as missing. Values range from 1 to 49 Number.

Missing value:

-99 : except SSPA and LNA analysis mode.

3. The List of Elements of the Data Group

3.1 The List of Elements of NS Data Group of 1BKu and 1BPR

Table 3.1-1 Elements of NS Data Group of 1BKu and 1BPR

(B:byte, int:integer)

Group Name	Variables [Array]	Missing (_fill Value)	Minimum Value	Maximum Value	Unit	Data Type
ScanTime	Year [nscan]	-9999	1950	2100	[years]	signed 2B int
	Month [nscan]	-99	1	12	[months]	signed 1B int
	DayOfMonth [nscan]	-99	1	31	[days]	signed 1B int
	Hour [nscan]	-99	0	23	[hours]	signed 1B int
	Minute [nscan]	-99	0	59	[minutes]	signed 1B int
	Second [nscan]	-99	0	60	[s]	signed 1B int
	MilliSecond [nscan]	-9999	0	999	[ms]	signed 2B int
	DayOfYear [nscan]	-9999	1	366	[days]	signed 2B int
	SecondOfDay [nscan]	-9999.9	0	86400	[s]	8B double
(N/A)	Latitude [nray][nscan]	-9999.9	-90	90	[degrees]	4B float
(N/A)	Longitude [nray][nscan]	-9999.9	-180	180	[degrees]	4B float
Receiver	echoPower [nbin][nray][nscan]	-30000	-12000	-2000	[dBm]	signed 2B int
	echoCount [nbin][nray][nscan]	0				unsigned 1B int
	noisePower [nray][nscan]	-30000	-12000	-2000	[dBm]	signed 2B int
	noiseSampleNumber [nray][nscan]	-9999	0	140		signed 2B int
	noiseCount [nray][nscan]	-9999.9				4B float
	echoSampleNumber [nray][nscan]	-99	0	60	[dB]	signed 1B int

3.1 The List of Elements of NS Data Group of 1BKu and 1BPR

	rxAntGain [nray][nscan]	-9999.9				4B float	
	receivedPulseWidth [nscan]	-9999.9			[s]	4B float	
Transmitter	radarTransPower [nscan]	-9999.9				4B float	
	transPulseWidth [nscan]	-9999.9	0.0000015	0.0000017	[s]	4B float	
	txAntGain [nray][nscan]	-9999.9			[dB]	4B float	
VertLocate	landOceanFlag [nray][nscan]		0	3		signed 2B int	
	scLocalZenith [nray][nscan]	-9999.9	0	90	[degrees]	4B float	
	startBinRange [nray][nscan]	-9999.9	350000	500000	[m]	4B float	
	echoHighResBinNumber [nray][nscan]	-9999	1	260		signed 2B int	
	echoLowResBinNumber [nray][nscan]	-9999	0	260		signed 2B int	
	binEllipsoid [nray][nscan]	-9999	1	260		signed 2B int	
	scRangeEllipsoid [nray][nscan]	-9999.9	0	500000	[m]	4B float	
	binDEM [nray][nscan]	-9999	1	260		signed 2B int	
	scRangeDEM [nray][nscan]	-9999.9	0	500000	[m]	4B float	
	DEMHmean [nray][nscan]	-9999	0	9000	[m]	signed 2B int	
	binDEMHtop [nray][nscan]	-9999	1	260		signed 2B int	
	binDEMHbottom [nray][nscan]	-9999	1	260		signed 2B int	
	binEchoPeak [nray][nscan]	-9999	1	260		signed 2B int	
	alongTrackBeamWidth [nray][nscan]					[degrees]	4B float
	crossTrackBeamWidth [nray][nscan]					[degrees]	4B float
	mainlobeEdge [nray][nscan]						signed 2B int

3.1 The List of Elements of NS Data Group of 1BKu and 1BPR

	sidelobeRange [nray][nscan]					signed 2B int
	ellipsoidBinOffset [nray][nscan]					4B float
	rangeBinSize [nscan]				[m]	4B float
	ratioLand [nray][nscan]					signed 1B int
	ratioOcean [nray][nscan]					signed 1B int
	ratioInLand [nray][nscan]					signed 1B int
	ratioCoast [nray][nscan]					signed 1B int
scanStatus	dataQuality [nscan]					signed 1B int
	dataWarning [nscan]					signed 1B int
	missing [nscan]					signed 1B int
	modeStatus [nscan]					signed 1B int
	geoError [nscan]					signed 2B int
	geoWarning [nscan]					signed 2B int
	Scorientation [nscan]	-9999				
	pointingStatus [nscan]	-9999				signed 2B int
	acsModeMidScan [nscan]					signed 1B int
	targetSelectionMidScan [nscan]	-99				signed 1B int
	operationalMode [nscan]		1	20		signed 1B int
	limitErrorFlag [nscan]					signed 1B int
	FractionalGranuleNumber [nscan]	-9999.9	0	100000		8B double

3.1 The List of Elements of NS Data Group of 1BKU and 1BPR

navigation	scPos [XYZ][nscan]	-9999.9	-10000000	10000000	[m]	4B float
	scVel [XYZ][nscan]	-9999.9	-10000000	10000000	[m/s]	4B float
	scLat [nscan]	-9999.9	-70	70	[degrees]	4B float
	scLon [nscan]	-9999.9	-180	180	[degrees]	4B float
	scAlt [nscan]	-9999.9	350000	500000	[m]	4B float
	dprAlt [nscan]	-9999.9	350000	500000	[m]	4B float
	scAttRollGeoc [nscan]	-9999.9	-180	180	[degrees]	4B float
	scAttPitchGeoc [nscan]	-9999.9	-180	180	[degrees]	4B float
	scAttYawGeoc [nscan]	-9999.9	-135	225	[degrees]	4B float
	scAttRollGeod [nscan]	-9999.9	-180	180	[degrees]	4B float
	scAttPitchGeod [nscan]	-9999.9	-180	180	[degrees]	4B float
	scAttYawGeod [nscan]	-9999.9	-135	225	[degrees]	4B float
	greenHourAng [nscan]	-9999.9	0	390	[degrees]	4B float
	timeMidScan [nscan]	-9999.9	0	10000000000	[s]	8B double
	timeMidScanOffset [nscan]	-9999.9	0	100	[s]	8B double
rayPointing	rayDirectionX [nray][nscan]	-9999.9	-1	1		4B float
	rayDirectionY [nray][nscan]	-9999.9	-1	1		4B float
	instrumentYaw [nray][nscan]	-9999.9	-135	225	[degrees]	4B float
	instrumentPitch [nray][nscan]	-9999.9	-90	90	[degrees]	4B float
	instrumentRoll [nray][nscan]	-9999.9	-180	180	[degrees]	4B float
	rayTiming [nray][nscan]	-9999.9	0	1.6	[s]	4B float
	scanAngle [nray][nscan]	-9999.9	-18	18	[degrees]	4B float

3.1 The List of Elements of NS Data Group of 1BKu and 1BPR

HouseKeeping	rxAtt [nscan]	-99	0	12	[dB]	signed 1B int
	rxAttGainOffset [nscan]	-9999.9	-260	260	[dB]	4B float
	binDiffPeakDEM [nray][nscan]	-9999	-260	260		signed 2B int
	scTime [nscan]	-9999.9				8B float
	vprfTableVersion [nscan]	-99	1	127		signed 1B int
	vprfTableSelect [nscan]		1	25		signed 1B int
	catchingInt [nscan]	-99	8	12		signed 1B int
	scdpFlag [nscan]					signed 1B int
	fcifFlag [nscan]		0	1		signed 1B int
	fcifFlagAB [nscan]	-99	0	1		signed 1B int
	rxGain [nray][nscan]	-9999.9				4B float
	scdpFlagAB [nscan]	-99	0	1		signed 1B int
	logAmpNoiseLevel [nscan]	-9999			[dBm]	signed 2B int
	Delay [nscan]	-9999	0	3360		signed 2B int
	seqCountL1A [nscan]	-9999	0	27000		signed 2B int
	fcifTemp [2 x nscan]	-9999	-5000	5000	[C]	signed 2B int
	lnaTemp [2 x nscan]	-9999	-5000	5000	[C]	signed 2B int
	rdaTemp [2x nscan]	-9999	-5000	5000	[C]	signed 2B int
	divcomb1Temp [2 x nscan]	-9999	-5000	5000	[C]	signed 2B int
	divcomb2Temp [2 x nscan]	-9999	-5000	5000	[C]	signed 2B int
sspaTemp [2 x nscan]	-9999	-5000	5000	[C]	signed 2B int	
Calibration	fcifInPower [nscan]	-32734			[dBm]	signed 2B int

3.1 The List of Elements of NS Data Group of 1BKU and 1BPR

	intAttSelect [nscan]	-99	1	32	[step]	signed 1B int
	sspaLnaSelect [nscan]	-9999	1	128		signed 2B int
	angleBinSelect [nscan]	-99	1	49		signed 1B int

3.2 The List of Elements of MS Data Group of 1BKa

Table3.2-1 The Elements of MS Data Group of 1BKa

(B:byte, int:integer)

Group Name	Variables [Array]	Missing (Fill Value)	Minimum Value	Maximum Value	Unit	Data Type
ScanTime	Year [nscan]	-9999	1950	2100	[years]	signed 2B int
	Month [nscan]	-99	1	12	[months]	signed 1B int
	DayOfMonth [nscan]	-99	1	31	[days]	signed 1B int
	Hour [nscan]	-99	0	23	[hours]	signed 1B int
	Minute [nscan]	-99	0	59	[minutes]	signed 1B int
	Second [nscan]	-99	0	60	[s]	signed 1B int
	MilliSecond [nscan]	-9999	0	999	[ms]	signed 2B int
	DayOfYear [nscan]	-9999	1	366	[days]	signed 2B int
	SecondOfDay [nscan]	-9999.9	0	86400	[s]	8B double
(N/A)	Latitude[nrayMS][nscan]	-9999.9	-90	90	[degrees]	4B float
(N/A)	Longitude [nrayMS][nscan]	-9999.9	-180	180	[degrees]	4B float
Receiver	echoPower [nbinMS][nrayMS][nscan]	-30000	-12000	-2000	[dBm]	signed 2B int
	echoCount [nbinMS][nrayMS][nscan]	0				unsigned 1B int
	noiseCount [nrayMS][nscan]	-9999.9				4B float
	noisePower [nrayMS][nscan]	-30000	-12000	-2000	[dBm]	signed 2B int
	noiseSampleNumber [nrayMS][nscan]	-9999	0	140		signed 2B int
	echoSampleNumber [nrayMS][nscan]	-99	0	60	[dB]	signed 1B int

3.2 The List of Elements of MS Data Group of 1BKa

	rxAntGain [nrayMS][nscan]	-9999.9				4B float
	receivedPulseWidth [nscan]	-9999.9			[s]	4B float
Transmitter	radarTransPower [nscan]	-9999.9				4B float
	transPulseWidth [nscan]	-9999.9	0.0000015	0.0000017	[s]	4B float
	txAntGain [nrayMS][nscan]	-9999.9			[dB]	4B float
VertLocate	landOceanFlag [nrayMS][nscan]		0	3		signed 2B int
	scLocalZenith [nrayMS][nscan]	-9999.9	0	90	[degrees]	4B float
	startBinRange [nrayMS][nscan]	-9999.9	350000	500000	[m]	4B float
	echoHighResBinNumber [nrayMS][nscan]	-9999	1	260		signed 2B int
	echoLowResBinNumber [nrayMS][nscan]	-9999	0	260		signed 2B int
	binEllipsoid [nrayMS][nscan]	-9999	1	260		signed 2B int
	scRangeEllipsoid [nrayMS][nscan]	-9999.9	0	500000	[m]	4B float
	binDEM [nrayMS][nscan]	-9999	1	260		signed 2B int
	scRangeDEM [nrayMS][nscan]	-9999.9	0	500000	[m]	4B float
	DEMHmean [nrayMS][nscan]	-9999	0	9000	[m]	signed 2B int
	binDEMHtop [nrayMS][nscan]	-9999	1	260		signed 2B int
	binDEMHbottom [nrayMS][nscan]	-9999	1	260		signed 2B int
	binEchoPeak [nrayMS][nscan]	-9999	1	260		signed 2B int
	alongTrackBeamWidth [nrayMS][nscan]				[degrees]	4B float
	crossTrackBeamWidth [nrayMS][nscan]				[degrees]	4B float
mainlobeEdge [nrayMS][nscan]					signed 2B int	

3.2 The List of Elements of MS Data Group of 1BKa

	sidelobeRange [nrayMS][nscan]					signed 2B int
	ellipsoidBinOffset [nrayMS][nscan]					4B float
	rangeBinSize [nscan]				[m]	4B float
	ratioLand [nrayMS][nscan]					signed 1B int
	ratioOcean [nrayMS][nscan]					signed 1B int
	ratioInLand [nrayMS][nscan]					signed 1B int
	ratioCoast [nrayMS][nscan]					signed 1B int
scanStatus	dataQuality [nscan]					signed 1B int
	dataWarning [nscan]					signed 1B int
	missing [nscan]					signed 1B int
	modeStatus [nscan]					signed 1B int
	geoError [nscan]					signed 2B int
	geoWarning [nscan]					signed 2B int
	SCorientation [nscan]	-9999				signed 2B int
	pointingStatus [nscan]	-9999				signed 2B int
	acsModeMidScan [nscan]					signed 1B int
	targetSelectionMidScan [nscan]	-99				signed 1B int
	operationalMode [nscan]			1	20	signed 1B int
	limitErrorFlag [nscan]					signed 1B int
	FractionalGranuleNumber [nscan]	-9999.9		0	100000	8B double

3.2 The List of Elements of MS Data Group of 1BKa

navigation	scPos [3][nscan]	-9999.9	-10000000	10000000	[m]	4B float
	scVel [3][nscan]	-9999.9	-10000000	10000000	[m/s]	4B float
	scLat [nscan]	-9999.9	-70	70	[degrees]	4B float
	scLon [nscan]	-9999.9	-180	180	[degrees]	4B float
	scAlt [nscan]	-9999.9	350000	500000	[m]	4B float
	dprAlt [nscan]	-9999.9	350000	500000	[m]	4B float
	scAttRollGeoc [nscan]	-9999.9	-180	180	[degrees]	4B float
	scAttPitchGeoc [nscan]	-9999.9	-180	180	[degrees]	4B float
	scAttYawGeoc [nscan]	-9999.9	-135	225	[degrees]	4B float
	scAttRollGeod [nscan]	-9999.9	-180	180	[degrees]	4B float
	scAttPitchGeod [nscan]	-9999.9	-180	180	[degrees]	4B float
	scAttYawGeod [nscan]	-9999.9	-135	225	[degrees]	4B float
	greenHourAng [nscan]	-9999.9	0	390	[degrees]	4B float
	timeMidScan [nscan]	-9999.9	0	10000000000	[s]	8B double
	timeMidScanOffset [nscan]	-9999.9	0	100	[s]	8B double
rayPointing	rayDirectionX [nrayMS][nscan]	-9999.9	-1	1		4B float
	rayDirectionY [nrayMS][nscan]	-9999.9	-1	1		4B float
	instrumentYaw [nrayMS][nscan]	-9999.9	-135	225	[degrees]	4B float
	instrumentPitch [nrayMS][nscan]	-9999.9	-90	90	[degrees]	4B float
	instrumentRoll [nrayMS][nscan]	-9999.9	-180	180	[degrees]	4B float
	rayTiming [nrayMS][nscan]	-9999.9	0	1.6	[s]	4B float
	scanAngle [nrayMS][nscan]	-9999.9	-18	18	[degrees]	4B float

3.2 The List of Elements of MS Data Group of 1BKa

HouseKeeping	rxAtt [nscan]	-99	0	12	[dB]	signed 1B int
	rxAttGainOffset [nscan]	-9999.9	-260	260	[dB]	4B float
	rxGain [nrayMS][nscan]	-9999.9			[dB]	4B float
	binDiffPeakDEM [nrayMS][nscan]	-9999	-260	260		signed 2B int
	scTime [nscan]	-9999.9				8B float
	vprfTableVersion [nscan]	-99	1	127		signed 1B int
	vprfTableSelect [nscan]		1	25		signed 1B int
	catchingInt [nscan]	-99	8	12		signed 1B int
	scdpFlag [nscan]					signed 1B int
	fcifFlag [nscan]					signed 1B int
	scdpFlagAB [nscan]	-99	0	1		signed 1B int
	fcifFlagAB [nscan]	-99	0	1		signed 1B int
	logAmpNoiseLevel [nscan]	-9999			[dBm]	signed 2B int
	delay [nscan]	-9999	0	3360		signed 2B int
	seqCountL1A [nscan]	-9999	0	27000		signed 2B int
	fcifTemp [2 x nscan]	-9999	-5000	5000	[C]	signed 2B int
	lnaTemp [2 x nscan]	-9999	-5000	5000	[C]	signed 2B int
	rdaTemp [2 x nscan]	-9999	-5000	5000	[C]	signed 2B int
	divcomb1Temp [2 x nscan]	-9999	-5000	5000	[C]	signed 2B int
	divcomb2Temp [2 x nscan]	-9999	-5000	5000	[C]	signed 2B int
sspaTemp [2 x nscan]	-9999	-5000	5000	[C]	signed 2B int	
Calibration	fcifInPower [nscan]	-32734			[dBm]	signed 2B int

3.2 The List of Elements of MS Data Group of 1BKa

	intAttSelect [nscan]	-99	1	32	[step]	signed 1B int
	sspaLnaSelect [nscan]	-9999	1	128		signed 2B int
	angleBinSelect [nscan]	-99	1	49		signed 1B int

3.3 The List of Elements of HS Data Group of 1BKa

Table 3.3-1 The Elements of HS Data Group of 1BKa

(B:byte, int:integer)

Group Name	Variables [Array]	Missing (Fill Value)	Minimum Value	Maximum Value	Unit	Data Type
ScanTime	Year [nscan]	-9999	1950	2100	[years]	signed 2B int
	Month [nscan]	-99	1	12	[months]	signed 1B int
	DayOfMonth [nscan]	-99	1	31	[days]	signed 1B int
	Hour [nscan]	-99	0	23	[hours]	signed 1B int
	Minute [nscan]	-99	0	59	[minutes]	signed 1B int
	Second [nscan]	-99	0	60	[s]	signed 1B int
	MilliSecond [nscan]	-9999	0	999	[ms]	signed 2B int
	DayOfYear [nscan]	-9999	1	366	[days]	signed 2B int
	SecondOfDay [nscan]	-9999.9	0	86400	[s]	8B double
Receiver	echoPower [nbinHS][nrayHS][nscan]	-30000	-12000	-2000	[dBm]	signed 2B int
	echoCount [nbinHS][nrayHS][nscan]	0				unsigned 1B int
	noisePower [nrayHS][nscan]	-30000	-12000	-2000	[dBm]	signed 2B int
	noiseCount [nrayHS][nscan]	-9999.9				4B float
	noiseSampleNumber [nrayHS][nscan]	-9999	0	140		signed 2B int
	echoSampleNumber [nrayHS][nscan]	-99	0	60	[dB]	signed 1B int
	rxAntGain [nrayHS][nscan]	-9999.9				4B float

3.3 The List of Elements of HS Data Group of 1BKa

	receivedPulseWidth [nscan]	-9999.9			[s]	4B float
Transmitter	radarTransPower [nscan]	-9999.9				4B float
	transPulseWidth [nscan]	-9999.9	0.0000015	0.0000017	[s]	4B float
	txAntGain [nrayHS][nscan]	-9999.9			[dB]	4B float
VertLocate	landOceanFlag [nrayHS][nscan]		0	3		signed 2B int
	scLocalZenith [nrayHS][nscan]	-9999.9	0	90	[degrees]	4B float
	startBinRange [nrayHS][nscan]	-9999.9	350000	500000	[m]	4B float
	echoHighResBinNumber [nrayHS][nscan]	-9999	1	260		signed 2B int
	echoLowResBinNumber [nrayHS][nscan]	-9999	0	260		signed 2B int
	binEllipsoid [nrayHS][nscan]	-9999	1	260		signed 2B int
	scRangeEllipsoid [nrayHS][nscan]	-9999.9	0	500000	[m]	4B float
	binDEM [nrayHS][nscan]	-9999	1	260		signed 2B int
	scRangeDEM [nrayHS][nscan]	-9999.9	0	500000	[m]	4B float
	DEMHmean [nrayHS][nscan]	-9999	0	9000	[m]	signed 2B int
	binDEMHTop [nrayHS][nscan]	-9999	1	260		signed 2B int
	binDEMHBOTTOM [nrayHS][nscan]	-9999	1	260		signed 2B int
binEchoPeak [nrayHS][nscan]	-9999	1	260		signed 2B int	

3.3 The List of Elements of HS Data Group of 1BKa

	alongTrackBeamWidth [nrayHS][nscan]				[degrees]	4B float
	crossTrackBeamWidth [nrayHS][nscan]				[degrees]	4B float
	mainlobeEdge [nrayHS][nscan]					signed 2B int
	sidelobeRange [nrayHS][nscan]					signed 2B int
	ellipsoidBinOffset [nrayHS][nscan]					4B float
	rangeBinSize [nscan]				[m]	4B float
	ratioLand [nrayHS][nscan]					signed 1B int
	ratioOcean [nrayHS][nscan]					signed 1B int
	ratioInLand [nrayHS][nscan]					signed 1B int
	ratioCoast [nrayHS][nscan]					signed 1B int
scanStatus	dataQuality [nscan]					signed 1B int
	dataWarning [nscan]					signed 1B int
	missing [nscan]					signed 1B int
	modeStatus [nscan]					signed 1B int
	geoError [nscan]					signed 2B int
	geoWarning [nscan]					signed 2B int
	SCorientation [nscan]	-9999				signed 2B int
	pointingStatus [nscan]	-9999				signed 2B int

3.3 The List of Elements of HS Data Group of 1BKa

	acsModeMidScan [nscan]					signed 1B int
	targetSelectionMidScan [nscan]	-99				signed 1B int
	operationalMode [nscan]		1	20		signed 1B int
	limitErrorFlag [nscan]					signed 1B int
	FractionalGranuleNumber [nscan]	-9999.9	0	100000		8B double
navigation	scPos [3][nscan]	-9999.9	-10000000	10000000	[m]	4B float
	scVel [3][nscan]	-9999.9	-10000000	10000000	[m/s]	4B float
	scLat [nscan]	-9999.9	-70	70	[degrees]	4B float
	scLon [nscan]	-9999.9	-180	180	[degrees]	4B float
	scAlt [nscan]	-9999.9	350000	500000	[m]	4B float
	dprAlt [nscan]	-9999.9	350000	500000	[m]	4B float
	scAttRollGeoc [nscan]	-9999.9	-180	180	[degrees]	4B float
	scAttPitchGeoc [nscan]	-9999.9	-180	180	[degrees]	4B float
	scAttYawGeoc [nscan]	-9999.9	-135	225	[degrees]	4B float
	scAttRollGeod [nscan]	-9999.9	-180	180	[degrees]	4B float
	scAttPitchGeod [nscan]	-9999.9	-180	180	[degrees]	4B float
	scAttYawGeod [nscan]	-9999.9	-135	225	[degrees]	4B float
	greenHourAng [nscan]	-9999.9	0	390	[degrees]	4B float
	timeMidScan [nscan]	-9999.9	0	10000000000	[s]	8B double
	timeMidScanOffset [nscan]	-9999.9	0	100	[s]	8B double
rayPointing	rayDirectionX [nrayHS][nscan]	-9999.9	-1	1		4B float

3.3 The List of Elements of HS Data Group of 1BKa

	rayDirectionY [nrayHS][nscan]	-9999.9	-1	1		4B float
	instrumentYaw [nrayHS][nscan]	-9999.9	-135	225	[degrees]	4B float
	instrumentPitch [nrayHS][nscan]	-9999.9	-90	90	[degrees]	4B float
	instrumentRoll [nrayHS][nscan]	-9999.9	-180	180	[degrees]	4B float
	rayTiming [nrayHS][nscan]	-9999.9	0	1.6	[s]	4B float
	scanAngle [nrayHS][nscan]	-9999.9	-18	18	[degrees]	4B float
HouseKeeping	rxAtt [nscan]	-99	0	12	[dB]	signed 1B int
	rxAttGainOffset [nscan]	-9999.9	-260	260	[dB]	4B float
	rxGain [nrayHS][nscan]	-9999.9			[dB]	4B float
	binDiffPeakDEM [nrayHS][nscan]	-9999	-260	260		signed 2B int
	scTime [nscan]	-9999.9				8B float
	vprfTableVersion [nscan]	-99	1	127		signed 1B int
	vprfTableSelect [nscan]		1	25		signed 1B int
	catchingInt [nscan]	-99	8	12		signed 1B int
	scdpFlag [nscan]					signed 1B int
	fcifFlag [nscan]					signed 1B int
	scdpFlagAB [nscan]	-99	0	1		signed 1B int
	fcifFlagAB [nscan]	-99	0	1		signed 1B int
	logAmpNoiseLevel [nscan]	-9999			[dBm]	signed 2B int
	delay [nscan]	-9999	0	3360		signed 2B int
	seqCountL1A [nscan]	-9999	0	27000		signed 2B int
fcifTemp [2][nscan]	-9999	-5000	5000	[C]	signed 2B int	

3.3 The List of Elements of HS Data Group of 1BKa

	InaTemp [2][nscan]	-9999	-5000	5000	[C]	signed 2B int
	rdaTemp [2][nscan]	-9999	-5000	5000	[C]	signed 2B int
	divcomb1Temp [2][nscan]	-9999	-5000	5000	[C]	signed 2B int
	divcomb2Temp [2][nscan]	-9999	-5000	5000	[C]	signed 2B int
	sspaTemp [2][nscan]	-9999	-5000	5000	[C]	signed 2B int
Calibration	fcifInPower [nscan]	-32734			[dBm]	signed 2B int
	intAttSelect [nscan]	-99	1	32	[step]	signed 1B int
	sspaLnaSelect [nscan]	-9999	1	128		signed 2B int
	angleBinSelect [nscan]	-99	1	49		signed 1B int

Index

I

1BKa.....	2, 4, 18, 64, 70
1BKu.....	2, 3, 18, 58

A

acsModeMidScan.....	38, 60, 66, 73
AlgorithmID.....	12, 16
AlgorithmVersion.....	12
alignmentAngleBasicEtoA.....	18
alignmentAngleOffsetAtoM.....	18
alongTrackBeamWidth.....	30, 59, 65, 72
angleBinSelect.....	56, 63, 69, 75
AttitudeFileName.....	14
AttitudeSource.....	15

B

binDEM.....	29, 47, 59, 65, 71
binDEMHbottom.....	30, 59, 65, 71
binDEMHtop.....	29, 59, 65, 71
binDiffPeakDEM.....	47, 62, 68, 74
binEchoPeak.....	30, 47, 59, 65, 71
binEllipsoid.....	28, 31, 40, 59, 65, 71
BlueprintFilename.....	16
BlueprintVersion.....	16

C

Calibration.....	10, 39, 55, 62, 68, 75
catchingInt.....	50, 62, 68, 74
crossTrackBeamWidth.....	30, 59, 65, 72

D

DataFormatVersion.....	16
dataQuality.....	33, 35, 36, 40, 60, 66, 72
dataWarning.....	33, 60, 66, 72
DayOfMonth.....	21, 58, 64, 70
DayOfYear.....	22, 58, 64, 70
delay.....	46, 51, 68, 74
DEMhmean.....	29, 59, 65, 71

dielectricConstantKa.....	18
dielectricConstantKu.....	17
divcomb1Temp.....	53, 62, 68, 75
divcomb2Temp.....	53, 62, 68, 75
DOI.....	12
DOIauthority.....	12
DOIshortName.....	12
dprAlt.....	42, 61, 67, 73
DPRKaInfo.....	18
DPRKuInfo.....	18

E

echoCount.....	24, 58, 64, 70
echoHighResBinNumber.....	28, 59, 65, 71
echoLowResBinNumber.....	28, 59, 65, 71
echoPower.....	23, 30, 58, 64
echoSampleNumber.....	25, 58, 64, 70
ellipsoidBinOffset.....	31, 60, 66, 72
EmptyGranule.....	13
EndianType.....	16
EphemerisFileName.....	14
EphemerisSource.....	15
eqvWavelength.....	18

F

fcifFlag.....	51, 62, 68, 74
fcifFlagAB.....	54, 62, 68, 74
fcifInPower.....	55, 62, 68, 75
fcifIoTableVersion.....	18
fcifTemp.....	52, 62, 68, 74
FileHeader.....	12
FileInfo.....	16
FileName.....	12
FirstScanLat.....	17
FirstScanLon.....	17
FormatPackage.....	16
FractionalGranuleNumber.....	40, 60, 66, 73

G

GenerationDateTime.....	13, 14
-------------------------	--------

GeoControlFileName	14
geoError.....	33, 35, 60, 66, 72
GeoToolkitVersion.....	15
geoWarning.....	33, 36, 60, 66, 72
GranuleFirstScanUTCDateTime	17
GranuleLastScanUTCDateTime	17
GranuleNumber	13
GranuleStart	13
greenHourAng	44, 61, 67, 73

H

Hour	21, 58, 64, 70
HouseKeeping	10, 46, 62, 68, 74
HS.....	2

I

InputAlgorithmVersions	14
InputFileNames	14
InputGenerationDateTimes	14
InputRecord.....	14
InstrumentName	13
instrumentPitch.....	45, 61, 67, 74
instrumentRoll.....	46, 61, 67, 74
instrumentYaw	45, 61, 67, 74
intAttSelect	55, 63, 69, 75

J

JAXAInfo	17
----------------	----

K

KaPR.....	17, 39
KuPR.....	17, 39

L

landOceanFlag.....	27, 59, 65, 71
LastScanLat.....	17
LastScanLon.....	17
Latitude	17, 20, 23, 35, 58, 64
lightspeed.....	17

limitErrorFlag.....	34, 40, 60, 66, 73
lnaTemp.....	52, 62, 68, 75
logAmpNoiseLevel	51, 62, 68, 74
logAveOffset.....	18
Longitude.....	17, 20, 23, 58, 64
LongitudeOnEquator.....	14

M

mainlobeEdge.....	31, 59, 65, 72
MaximumNumberScansTotal	19
MeanSolarBetaAngle	14
MetadataStyle.....	16
MetadataVersion.....	16
MilliSecond.....	22, 58, 64, 70
Minute	22, 58, 64, 70
missing	60, 66, 72
MissingData	13
modeStatus.....	33, 34, 37, 40, 60, 66, 72
Month.....	21, 58, 64, 70
MS	2

N

navigation	9, 14, 41, 61, 67, 73
NavigationRecord	14
nbin	2
noiseCount	24, 58, 64, 70
noisePower.....	24, 58, 64, 70
noiseSampleNumber	24, 58, 64, 70
nray	2
NS.....	2
nscan	2
NumberOfGrids.....	13
NumberOfRainPixelsHS.....	17
NumberOfRainPixelsMS	17
NumberOfRainPixelsNS.....	17
NumberOfSwaths	13
NumberPixels.....	19
NumberScansAfterGranule	19
NumberScansBeforeGranule	19
NumberScansGranule.....	19
NumberScansInSet.....	19

O

operationalMode 34, 39

P

pointingStatus 34, 37, 60, 66, 72
ProcessingMode 17
ProcessingSubSystem 17
ProcessingSystem 13
ProductVersion 13

R

radarTransPower 25, 59, 65, 71
rangeBinSize 31, 60, 66, 72
ratioCoast 32, 60, 66, 72
ratioInLand 32, 60, 66, 72
ratioLand 32, 60, 66, 72
ratioOcean 32, 60, 66, 72
rayDirectionX 45, 61, 67, 73
rayDirectionY 45, 61, 67, 74
rayPointing 9, 45, 61, 67, 73
rayTiming 46, 61, 67, 74
rdaTemp 53, 62, 68, 75
receivedPulseWidth 25, 59, 65, 71
Receiver 5, 23, 58, 64, 70
rxAntGain 25, 59, 65, 70
rxAtt 46, 47, 62, 68, 74
rxAttGainOffset 47, 62, 68, 74
rxGain 54, 62, 68, 74

S

SatelliteName 13
scAlt 42, 61, 67, 73
scanAngle 46, 61, 67, 74
scanAngleExtVersion 18
scanAngleObsVersion 18
scanStatus 8, 33, 40, 60, 66, 72
ScanTime 5, 21, 58, 64, 70
ScanType 19
scAttPitchGeoc 43, 61, 67, 73
scAttPitchGeod 43, 61, 67, 73
scAttRollGeoc 42, 61, 67, 73

scAttRollGeod 43, 61, 67, 73
scAttYawGeoc 43, 61, 67, 73
scAttYawGeod 44, 61, 67, 73
scdpFlag 50, 62, 68, 74
scdpFlagAB 54, 62, 68, 74
scLat 41, 61, 67, 73
scLocalZenith 27, 59, 65, 71
scLon 41, 61, 67, 73
Scorientation 60
SCorientation 66, 72
scPos 41, 44, 61, 67, 73
scRangeDEM 29, 59, 65, 71
scRangeEllipsoid 28, 29, 59, 65, 71
scTime 47, 62, 68, 74
scVel 41, 44, 61, 67, 73
Second 22, 58, 64, 70
SecondOfDay 22, 58, 64, 70
SensorAlignmentFirstRotationAngle 15
SensorAlignmentFirstRotationAxis 15
SensorAlignmentSecondRotationAngle 15
SensorAlignmentSecondRotationAxis 15
SensorAlignmentThirdRotationAngle 15
SensorAlignmentThirdRotationAxis 15
seqCountLIA 52, 62, 68, 74
sidelobeRange 31, 60, 66, 72
sspaLnaSelect 56, 63, 69, 75
sspaTemp 54, 62, 68, 75
startBinRange 27, 59, 65, 71
StartGranuleDateTime 13
StopGranuleDateTime 13
SwathHeader 13, 19

T

targetSelectionMidScan 38, 60, 66, 73
TimeInterval 13
timeMidScan 44, 61, 67, 73
timeMidScanOffset 44, 61, 67, 73
TKCodeBuildVersion 16
TKIOVersion 16
totalCoefVersion 18
TotalQualityCode 17
Transmitter 6, 25, 59, 65, 71
transPulseWidth 25, 59, 65, 71
transReceiverCoefVersion 18

txAntGain 27, 59, 65, 71

vprfTableSelect48, 49, 62, 68, 74

vprfTableVersion.....47, 62, 68, 74

U

UTCDateTimeOnEquator 14

Y

Year21, 58, 64, 70

V

VertLocate 7, 27, 59, 65, 71