



**PALSAR-2**

**Level 1.1/2.1/1.5/3.1 CEOS SAR Product**

**Format Description**

**December 6, 2021**

**Japan Aerospace Exploration Agency**



**PALSAR-2**

**Level 1.1/1.5/3.1 CEOS SAR Product**

**Format Description**

**Japan Aerospace Exploration Agency**

ALOS-2 Product Format Description  
CEOS Level 1.1/1.5/3.1 Revision History (1/7)

Rev.	Date	Revision Contents	Remark
NC	2012/12/28	First Edition	
A	2014/05/16	P22 P38 P90 Table 3.3-14 Field No.18 P95 Table 3.3-15 Field No.18 P.125 Table 4.3-1 No.44 Removed the statement about compact polarimetry.	
		P24, 28-29 Changed the figure numbers. Before: Figure 3-1, 3-2, 3-3, 3-4, 3-5 After: Figure 3.1-1, 3.1-2, 3.1-3, 3.1-4, 3.1-5	
		P31 Table 3.2-1 P34 Table 3.2-18 P77 Table 3.3-11 (1/2) P78 Table 3.3-11 (2/2) Removed the statement about predicted ephemeris.	
		P35 Added the description of Table 3.3-19 to Table 3.3-27.	

ALOS-2 Product Format Description  
CEOS Level 1.1/1.5/3.1 Revision History (2/7)

Rev.	Date	Revision Contents	Remark
A cont.		<p>P36 Table 3.3-1 Field No.12  P44 Table 3.3-4 Field No.12  P83 Table 3.3-13 Field No.12  P98 Table 3.3-16 Field No.12  Revised the format of “Software release and revision level”.</p> <p>Before:  (Description)  Software release and revision level = 'NN.NNbbbbbb'  1.00, 1.01, ... 1.10, ... 2.00  (Remarks)  b1.00bbbbbb</p> <p>After:  (Description)  Software release and revision level = 'NNN.NNNbbbbbb'  001.000, 001.001, ... 001.100, ... 002.000  (Remarks)  001.000bbbbbb</p>	
		<p>P50 Table 3.3-5 Field No.34  Removed the statement about periodical calibration.</p>	

ALOS-2 Product Format Description  
CEOS Level 1.1/1.5/3.1 Revision History (3/7)

Rev.	Date	Revision Contents	Remark
A cont.		P50 Table 3.3-5 Field No.34 Added suffix: “mode.” Before: '01': Ultra-fine '02': High-sensitive '03': Fine '18': Full (Quad.) pol./High-sensitive '19': Full (Quad.) pol./Fine After: '01': Ultra-fine mode '02': High-sensitive mode '03': Fine mode '18': Full (Quad.) pol./High-sensitive mode '19': Full (Quad.) pol./Fine mode	
		P53 Table 3.3-5 Field No.82 Revised the format of “Processing version ID” Before: NN.NNbbb After: NNN.NNNb	
		P55 Table 3.3-5(8/16) Field No.100, 101, 102, 104 P56 Table 3.3-5(9/16) Field No.105, 106, 109, 110, 111 P57 Table 3.3-5(10/16) Field No.113, 114, 115 P81 Table 3.3-12(3/4) Field No.21 P82 Table 3.3-12(4/4) Field No.24 Added the description of the values in the case of ScanSAR level 1.1	
		P57 Table 3.3-5 Field No.118 and 119 Revised the descriptions. Before: 'NO..bb' After: 'NObb'	
		P119 Table 4.3-1 No.9 Changed the figure numbers. Before: Figure 4-1 After: Figure 4.3-1	

ALOS-2 Product Format Description  
CEOS Level 1.1/1.5/3.1 Revision History (4/7)

Rev.	Date	Revision Contents	Remark
A cont.		P122 Corrected the spelling. Before: PS reference logitude After: PS reference longitude	
		P125 Table 4.3-1 No.42 Revised the description about the value of “Data size of product.” Before: Mbytes = 1024Kbyte After: Mbyte = 1024Kbyte	
		P.125 Table 4.3-1 No.43 Added the number of files in the case of level 1.1 ScanSAR mode products. Before: * Level 1.1 ScanSAR mode product: ScanSAR nominal mode (Single pol.) ScanSAR wide mode (Single pol.) ScanSAR nominal mode (Dual pol.) ScanSAR wide mode (Dual pol.) After: * Level 1.1 ScanSAR mode product: ScanSAR nominal mode (Single pol.) : 8 files ScanSAR wide mode (Single pol.) : 10 files ScanSAR nominal mode (Dual pol.) : 13 files ScanSAR wide mode (Dual pol.) : 17 files	
		P129-132 Changed the figure numbers. Before: Figure 5-1, 5-2, 5-3, 5-4, 5-5 After: Figure 5.2-1, 5.2-2, 5.2-3, 5.2-4, 5.2-5	
B		Missing number	

ALOS-2 Product Format Description

CEOS Level 1.1/1.5/3.1 Revision History (5/7)

C	2015/2/10	<p>P.39 Table 3.3-2 (2/3) No.15</p> <p>Correct the number of records.</p> <p>Before:</p> <p style="padding-left: 20px;">Leader file = 'bbbbbb17' : Level 1.1  'bbbbbb18' : Level 1.5 / 3.1</p> <p style="padding-left: 20px;">Trailer file = N+1 (N is the number of low resolution image data records)</p> <p>After:</p> <p style="padding-left: 20px;">Leader file = 'bbbbbb11' : Level 1.1  'bbbbbb12' : Level 1.5 / 3.1</p> <p style="padding-left: 20px;">Trailer file = N+1 (N is the number of Scan) : ScanSAR and Level 1.1  = 'bbbbbb2' : Other</p>	
		<p>P.40 Table 3.3-2 (3/3) No.23</p> <p>Correct the number of records.</p> <p>Before:</p> <p style="padding-left: 20px;">Leader file = 'bbbbbb17' : Level 1.1  'bbbbbb18' : Level 1.5 / 3.1</p> <p style="padding-left: 20px;">Trailer file = N+1 (N is the number of low resolution image data records)</p> <p>After:</p> <p style="padding-left: 20px;">Leader file = 'bbbbbb11' : Level 1.1  'bbbbbb12' : Level 1.5 / 3.1</p> <p style="padding-left: 20px;">Trailer file = N+1 (N is the number of Scan) : ScanSAR and Level 1.1  = 'bbbbbb2' : Other</p>	
		<p>P.68 Table 3.3-7 (1/3) No.11-13</p> <p>Correct the descriptions.</p> <p>Before : Position vector in the earth ///</p> <p>After : Velocity vector in the earth ///</p>	

ALOS-2 Product Format Description  
CEOS Level 1.1/1.5/3.1 Revision History (6/7)

C cont.	<p>P.91 Table 3.3-14 (3/5) No.36 Removed the description. Before : Data record window position (SAMPLE DELAY [nsec]) = 0)<sub>10</sub> After : Data record window position (SAMPLE DELAY [nsec])</p>	
	<p>P.67 Table 3.3-6 (4/4) No.77, 78 P.79 Table 3.3-12 (1/4) No. 8 Revised the recommendation about usage of the coefficients</p> <p>P.67 Table 3.3-6 (4/4) No.77 Before : Recommend to use the coefficients of 1025-2024 bytes in facility related data record 5  After : The coefficients of 1025-2024 bytes in facility related data record 5 should be used if high position accuracy is needed.</p> <p>P.67 Table 3.3-6 (4/4) No.78 Before : Recommend to use the coefficients of 2065-3064 bytes in facility related data record 5  After : The coefficients of 2065-3064 bytes in facility related data record 5 should be used if high position accuracy is needed.</p> <p>P.79 Table 3.3-12 (1/4) No. 8 Before : (Recommend to use the coefficients of 2065-3064 bytes)  After : The coefficients of 2065-3064 bytes in facility related data record 5 should be used if high position accuracy is needed.</p>	



ALOS-2 Product Format Description  
CEOS Level 1.1/1.5/3.1 Revision History (7/7)

C cont.		<p>P.81 Table 3.3-12 (3/4) No.22 and No.23 Removed the description. Before : No.22 : Origin Pixel (P0) 0.0 fixed No.23 : Origin Line (L0) 0.0 fixed After : No.22 : Origin Pixel (P0) 0.0 No.23 : Origin Line (L0) 0.0</p>	
D	2015/08/24	<p>P.66-67 Table 3.3-6 (3/5) and (4/5) No. 57 to No.64 Added the note to clarify the provision. “at the center of pixel” or “same as above”</p>	
E	2016/04/15	<p>P.8-10 Table 2.2-7 to Table 2.2-9 Corrected the values of “Azimuth Pixel” and “Data Volume”.</p>	
F	2016/08/10	<p>P74 Table 3.3-9 Radiometric data record (1/2) Added the remarks of the field No.9, Calibration Factor: “except ScanSAR level 1.1 product by the full aperture method”</p>	

ALOS-2 Product Format Description  
(CEOS Level 1.1/1.5/3.1 Format)

Table of Contents

1. Overview .....	1
2. Product Specifications .....	2
2.1. Definition of Processing Levels .....	2
2.2. Definition of Scene .....	3
2.2.1. Scene Size .....	3
2.2.2. Data Volume of Scene .....	3
2.3. Format .....	21
2.4. Product Description .....	21
2.5. Processing Parameter .....	23
3. Product Formats .....	24
3.1. Composition of CEOS Product .....	24
3.2. Record Structure of CEOS Product .....	30
3.2.1. Record Data Type .....	32
3.2.2. Record Type Code and Record Sub-type Code .....	32
3.3. Contents of Records in CEOS Files .....	35
4. Summary Information .....	120
4.1. Outline of Summary Information .....	120
4.2. Filename of Summary Information .....	120
4.3. File Format of Summary Information .....	120
4.3.1. Format Definition of Keyword .....	120
4.3.2. Format Definition of Value .....	120
4.3.3. Contents of Summary Information .....	120
5. Appendix .....	129
5.1. Thumbnail Image .....	129
5.2. Image File of ScanSAR Level 1.1 Product .....	130
5.2.1. Processing Mode and Data Storage Outline of ScanSAR Level 1.1 Product .....	130
5.2.2. Acquisition of Parameters from Image File in SPECAN method .....	134
5.3. Low Resolution Image Data Record .....	138

## 1. Overview

This document describes the CEOS (Committee on Earth Observation Satellites) SAR format specifications for ALOS-2 Level 1.1/1.5/3.1 products which are generated with ALOS-2 Data Processing System. The formats are based on the CEOS SAR formats of the ALOS/PALSAR products to take user friendliness into account and added new items for ALOS-2.

## 2. Product Specifications

### 2.1. Definition of Processing Levels

The definition of processing levels of ALOS-2 products is shown in Table 2.1-1. This document describes the data formats for CEOS level 1.1/1.5/3.1 products.

**Table 2.1-1 Definition of Processing Levels**

Level	Definition	Remark
1.0	Data corresponding to a scene area is extracted from received data. Data type is 8 bit. In the case of multi-polarization modes, the number of SAR data files is equal to the number of polarizations. In the case of ScanSAR mode, the data file is not divided into each scan. In the case of ATI and compact polarimetry observations, only level 1.0 product is generated.	
1.1	Range and single look azimuth compressed data is represented by complex I and Q channels to preserve the magnitude and phase information. Range coordinate is in slant range. L1.1 image is focused onto zero Doppler direction. In the case of ScanSAR mode, an image file is generated per each scan.	SLC: Single Look Complex. Interferometry processing requires SLC data.
1.5	Range and multi-look azimuth compressed data is represented by amplitude data. Range coordinate is converted from slant range to ground range, and map projection is performed. Pixel spacing is selectable depending on observation modes. There are two methods to transform image coordinate; G: Image coordinate in map projection is geocoded. R: Image coordinate in map projection is georeferenced.	G or R is selectable.
2.1	Level 2.1 data is orthorectified from level 1.1 data by using digital elevation model. Pixel spacing is selectable depending on observation modes. Image coordinate in map projection is geocoded.	
3.1	Image quality corrections (noise reduction and dynamic range compression) are performed to level 1.5 data.	

## 2.2. Definition of Scene

### 2.2.1. Scene Size

Scene sizes for level 1.1/1.5/3.1 products of each observation mode are shown in Table 2.2-1 and Table 2.2-2.

**Table 2.2-1 Scene Size for Level 1.1/1.5/3.1 Products  
(Except Full (Quad.) Polarimetry)**

Observation Mode	Spotlight	Ultra-Fine	High-sensitive	Fine	ScanSAR nominal [28MHz]	ScanSAR nominal [14MHz]	ScanSAR wide [490km]
Length of Range Direction	25km	55km	55km	70km	350.5km	350.5km	489.5km
Length of Azimuth Direction	25km	70km	70km	70km	355km	355km	355km
Time Duration of Azimuth Direction	N/A	10sec	10sec	10sec	52sec	52sec	52sec
Range Resolution*	3.0m	3.0m	6.0m	9.1m	47.5m(5look)	95.1m(5look)	44.2m(2look)
Azimuth Resolution*	1.0m	3.0m	4.3m	5.3m	77.7m(3look)	77.7m(3look)	56.7m(1.5look)

\*: The values in Table 2.2-1 are defined as those in single look processing and at the incidence angle 37 deg (unless otherwise noted).

**Table 2.2-2 Scene Size for Level 1.1/1.5/3.1 Products (Full (Quad.) Polarimetry)**

Observation Mode	High-sensitive	Fine
Length of Range Direction	40-50km	30km
Length of Azimuth Direction	70km	70km
Time Duration of Azimuth Direction	10sec	10sec
Range Resolution*	5.1m	8.7m
Azimuth Resolution*	4.3m	5.3m

\*: The values in Table 2.2-2 are defined as those in single look processing and at the incidence angle 37 deg (unless otherwise noted).

### 2.2.2. Data Volume of Scene

The number of pixels and the data volumes for each observation mode and each offnadir angle are shown in Table 2.2-3 - Table 2.2-21.

**Table 2.2-3 Level 1.1 Image Size and Volume for Spotlight Mode**

Spotlight Mode			
Off-nadir Angle [deg]	Range Pixel	Azimuth Pixel	Data Volume [MB]
7.3	2439	50000	930
13.6	4514	50000	1722
18.1	5964	50000	2275
22.6	7378	50000	2814
27.1	8746	50000	3336
31.5	10032	50000	3827
33.22	10519	50000	4013
35.8	11232	50000	4285
40.1	12368	50000	4718
44.2	13387	50000	5107
48.2	14315	50000	5461
52.1	15132	50000	5772
55.6	15845	50000	6044
58.8	16426	50000	6266

**Table 2.2-4 Level 1.1 Image size and Volume for Ultra-Fine Mode  
(Single Polarization)**

Ultra-Fine Mode			
Off-nadir Angle [deg]	Range Pixel	Azimuth Pixel	Data Volume [MB]
9.6	6719	30164	1546
13.9	9679	30164	2228
18.0	12452	30164	2866
21.9	15031	30164	3460
25.6	17415	30164	4008
29.1	20535	30164	4726
32.4	22627	30164	5208
35.4	24464	30164	5630
38.2	26119	30164	6010
40.6	24990	30164	5752
42.7	26042	30164	5994
44.7	27012	30164	6216
46.4	27811	30164	6400
48.0	28541	30164	6568
49.5	29204	30164	6720
50.9	29805	30164	6860
52.1	30307	30164	6974
53.3	30795	30164	7086
54.3	31191	30164	7178
55.3	31578	30164	7268
56.2	31917	30164	7346
57.0	32213	30164	7414
57.7	32466	30164	7472
58.4	32715	30164	7528

\*: In the case of dual polarization, the data volume is twice as that of a single polarization.

**Table 2.2-5 Level 1.1 Image size and Volume for High-sensitive Mode  
(Single Polarization)**

High-sensitive Mode			
Off-nadir Angle [deg]	Range Pixel	Azimuth Pixel	Data Volume [MB]
9.6	3359	27400	702
13.9	4839	27400	1012
18.0	6225	27400	1302
21.9	7514	27400	1570
25.6	8706	27400	1820
29.1	10266	27400	2146
32.4	11311	27400	2364
35.4	12230	27400	2556
38.2	13057	27400	2730
40.6	12492	27400	2612
42.7	13019	27400	2722
44.7	13504	27400	2822
46.4	13903	27400	2906
48.0	14268	27400	2982
49.5	14599	27400	3052
50.9	14900	27400	3114
52.1	15150	27400	3168
53.3	15394	27400	3218
54.3	15592	27400	3260
55.3	15786	27400	3300
56.2	15956	27400	3336
57.0	16103	27400	3366
57.7	16230	27400	3392
58.4	16354	27400	3418

\*: In the case of dual polarization, the data volume is twice as that of a single polarization.



**Table 2.2-6 Level 1.1 Image size and Volume for Fine Mode  
(Single Polarization)**

Fine Mode			
Off-nadir Angle [deg]	Range Pixel	Azimuth Pixel	Data Volume [MB]
9.8	2608	13700	273
14.7	3889	13700	406
19.4	5092	13700	532
23.8	6187	13700	647
28.2	8452	13700	883
32.5	9612	13700	1005
36.2	9813	13700	1026
39.3	9716	13700	1016
41.9	10245	13700	1071
44.3	10715	13700	1120
46.4	10185	13700	1065
48.2	10485	13700	1096
49.8	10743	13700	1123
51.2	9966	13700	1042
52.4	10132	13700	1059
53.5	10280	13700	1074
54.6	10424	13700	1090
55.5	10012	13700	1046
56.3	10639	13700	1112
57.1	9127	13700	954
57.8	10821	13700	1131
58.5	10904	13700	1140

\*: In the case of dual polarization, the data volume is twice as that of a single polarization.

**Table 2.2-7 Level 1.1 Image size and Volume for ScanSAR nominal [14MHz] Mode  
(Single Polarization, SPECAN Method \*1)**

ScanSAR Mode					
Scan Mode	Scan No.	Off-nadir Angle [deg]	Range Pixel	Azimuth Pixel	Data Volume [MB]
5	1	9.1	1468	70000	784
	2	15.1	2418	70000	1291
	3	20.7	3282	70000	1753
	4	26.2	4523	70000	2416
	5	30.8	4265	105000	3417
	total				
5	1	26.2	4523	70000	2416
	2	30.8	4265	87500	2847
	3	34.9	5499	70000	2937
	4	38.6	5597	70000	2989
	5	41.8	6194	87500	4135
	total				
5	1	41.8	6194	70000	3308
	2	44.7	6538	52500	2619
	3	47.3	6831	52500	2736
	4	49.5	7069	70000	3775
	5	51.5	7275	70000	3885
	total				
5	1	53.2	7444	52500	2982
	2	54.7	7588	52500	3039
	3	56.1	7717	70000	4121
	4	57.3	7824	70000	4178
	5	58.3	7911	70000	4225
	total				

E

\*1: SPECAN: SPECTral ANalysis

\*2: In the case of dual polarization, the data volume is twice as that of a single polarization.

**Table 2.2-8 Level 1.1 Image size and Volume for ScanSAR nominal [28MHz] Mode  
(Single Polarization, SPECAN Method)**

ScanSAR Mode					
Scan Mode	Scan No.	Off-nadir Angle [deg]	Range Pixel	Azimuth Pixel	Data Volume [MB]
5	1	9.1	2927	70000	1563
	2	15.1	4822	70000	2575
	3	20.7	6545	70000	3495
	4	26.2	9021	70000	4818
	5	30.8	8506	105000	6814
	total				
5	1	26.2	9021	70000	4818
	2	30.8	8506	87500	5678
	3	34.9	10966	70000	5856
	4	38.6	11164	70000	5962
	5	41.8	12354	87500	8247
	total				
5	1	41.8	12354	70000	6598
	2	44.7	13038	52500	5222
	3	47.3	13624	52500	5457
	4	49.5	14097	70000	7529
	5	51.5	14510	70000	7749
	total				
5	1	53.2	14846	52500	5946
	2	54.7	15133	52500	6061
	3	56.1	15390	70000	8219
	4	57.3	15604	70000	8333
	5	58.3	15776	70000	8425
	total				

E

\*: In the case of dual polarization, the data volume is twice as that of a single polarization.

**Table 2.2-9 Level 1.1 Image size and Volume for ScanSAR wide Mode  
(Single Polarization, SPECAN Method)**

ScanSAR Mode					
Scan Mode	Scan No.	Off-nadir Angle [deg]	Range Pixel	Azimuth Pixel	Data Volume [MB]
7	1	9.1	1468	35000	392
	2	15.1	2418	35000	646
	3	20.7	3282	35000	876
	4	26.2	4100	35000	1095
	5	30.8	4756	52500	1905
	6	34.9	5316	35000	1420
	7	38.6	5797	35000	1548
	total				
7	1	34.9	5316	35000	1420
	2	38.6	5797	35000	1548
	3	41.8	6194	35000	1654
	4	44.7	6538	35000	1746
	5	47.3	6831	35000	1824
	6	49.5	7069	35000	1888
	7	51.5	7275	35000	1943
	total				
7	1	49.5	7069	17500	944
	2	51.5	7275	17500	971
	3	53.2	7444	35000	1988
	4	54.7	7588	35000	2026
	5	56.1	7717	35000	2061
	6	57.3	7824	35000	2089
	7	58.3	7911	35000	2112
	total				

E

\*: In the case of dual polarization, the data volume is twice as that of a single polarization.

**Table 2.2-10 Level 1.1 Image size and Volume for ScanSAR nominal [14MHz] Mode  
(Single Polarization, Full Aperture Method)**

ScanSAR Mode					
Scan Mode	Scan No.	Off-nadir Angle [deg]	Range Pixel	Azimuth Pixel	Data Volume [MB]
5	1	9.1	1468	136764	1532
	2	15.1	2418	135890	2507
	3	20.7	3282	136284	3413
	4	26.2	4523	135954	4691
	5	30.8	4265	136640	4446
	total				
5	1	26.2	4523	135828	4687
	2	30.8	4265	136730	4449
	3	34.9	5499	136620	5732
	4	38.6	5597	136468	5827
	5	41.8	6194	136372	6444
	total				
5	1	41.8	6194	136230	6438
	2	44.7	6538	136800	6824
	3	47.3	6831	135408	7057
	4	49.5	7069	136320	7352
	5	51.5	7275	135150	7501
	total				
5	1	53.2	7444	136462	7750
	2	54.7	7588	135474	7843
	3	56.1	7717	136192	8018
	4	57.3	7824	136274	8135
	5	58.3	7911	135488	8178
	total				

\*: In the case of dual polarization, the data volume is twice as that of a single polarization.

**Table 2.2-11 Level 1.1 Image size and Volume for ScanSAR nominal [28MHz] Mode  
(Single Polarization, Full Aperture Method)**

ScanSAR Mode					
Scan Mode	Scan No.	Off-nadir Angle [deg]	Range Pixel	Azimuth Pixel	Data Volume [MB]
5	1	9.1	2927	136764	3054
	2	15.1	4822	135890	4999
	3	20.7	6545	136284	6805
	4	26.2	9021	135954	9357
	5	30.8	8506	136640	8867
	total				
5	1	26.2	9021	136730	9410
	2	30.8	8506	136620	8866
	3	34.9	10966	136468	11417
	4	38.6	11164	136372	11615
	5	41.8	12354	136230	12840
	total				
5	1	41.8	12354	136230	12840
	2	44.7	13038	136800	13608
	3	47.3	13624	135408	14075
	4	49.5	14097	136320	14661
	5	51.5	14510	135150	14961
	total				
5	1	53.2	14846	136462	15457
	2	54.7	15133	135474	15641
	3	56.1	15390	136192	15991
	4	57.3	15604	136274	16223
	5	58.3	15776	135488	16308
	total				

\*: In the case of dual polarization, the data volume is twice as that of a single polarization.

**Table 2.2-12 Level 1.1 Image size and Volume for ScanSAR wide Mode  
(Single Polarization, Full Aperture Method)**

ScanSAR Mode					
Scan Mode	Scan No.	Off-nadir Angle [deg]	Range Pixel	Azimuth Pixel	Data Volume [MB]
7	1	9.1	1468	136764	1532
	2	15.1	2418	135890	2507
	3	20.7	3282	136284	3413
	4	26.2	4100	135954	4253
	5	30.8	4756	136640	4958
	6	34.9	5316	135828	5509
	7	38.6	5797	136730	6047
	total				
7	1	34.9	5316	136620	5541
	2	38.6	5797	136468	6036
	3	41.8	6194	136372	6444
	4	44.7	6538	136230	6795
	5	47.3	6831	136800	7130
	6	49.5	7069	135408	7303
	7	51.5	7275	136320	7566
	total				
7	1	49.5	7069	135150	7289
	2	51.5	7275	136462	7574
	3	53.2	7444	135474	7694
	4	54.7	7588	136192	7884
	5	56.1	7717	136274	8023
	6	57.3	7824	135488	8088
	7	58.3	7911	135150	8157
	total				

\*: In the case of dual polarization, the data volume is twice as that of a single polarization.

**Table 2.2-13 Level 1.1 Image size and Volume for High-sensitive Mode  
(Full (Quad.) Polarization)**

High-sensitive Mode (Full (Quad.) pol.)			
Off-nadir Angle [deg]	Range Pixel	Azimuth Pixel	Data Volume [MB]
			FP
17.5	5769	22187	3908
21.3	6970	22187	4720
24.8	8049	22187	5448
27.8	8950	22187	6060
30.2	9653	22187	6536
32.5	10312	22187	6984
34.7	10926	22187	7396



**Table 2.2-14 Level 1.1 Image size and Volume for Fine Mode  
(Full (Quad.) Polarization)**

Fine Mode (Full (Quad.) pol.)			
Off-nadir Angle [deg]	Range Pixel	Azimuth Pixel	Data Volume [MB]
			FP
21.5	5117	13700	2140

**Table 2.2-15 Level 1.5/3.1 Image Size and Volume for Spotlight Mode (Geo-reference)**

Spotlight Mode			
Image Size Range×Azimuth	Number of Pixels & Data Volume [MB]		
	Pixel Spacing : 0.625m		
	Range	Azimuth	Data Volume [MB]
25×25 km	40000	40000	3051

\* Data Volume shows the value for single polarization.

**Table 2.2-16 Level 1.5/3.1 Image Size and Volume for Ultra-Fine Mode  
(Geo-reference)**

Ultra-Fine Mode			
Image Size Range×Azimuth	Number of Pixels & Data Volume [MB]		
	Pixel Spacing : 2.5m		
	Range	Azimuth	Data Volume [MB]
55×70 km	22000	28000	1175
52.5×70 km	21000	28000	1122
50×70 km	20000	28000	1068

\* Data Volume shows the value for single polarization.

**Table 2.2-17 Level 1.5/3.1 Image Size and Volume for High-sensitive Mode  
(Geo-reference)**

High-sensitive Mode			
Image Size Range×Azimuth	Number of Pixels & Data Volume [MB]		
	Pixel Spacing : 3.125m		
	Range	Azimuth	Data Volume [MB]
55×70 km	17600	22400	752
52.5×70 km	16800	22400	718
50×70 km	16000	22400	683

\* Data Volume shows the value for single polarization.

**Table 2.2-18 Level 1.5/3.1 Image Size and Volume for Fine Mode  
(Geo-reference)**

Fine Mode			
Image Size Range×Azimuth	Number of Pixels & Data Volume [MB]		
	Pixel Spacing : 6.25m (2 looks)		
	Range	Azimuth	Data Volume [MB]
70×70 km	11200	11200	239
65×70 km	10400	11200	222
60×70 km	9600	11200	205
55×70 km	8800	11200	188
50×70 km	8000	11200	171

\* Data Volume shows the value for single polarization.

**Table 2.2-19 Level 1.5/3.1 Image Size and Volume for ScanSAR Mode  
(Geo-reference)**

ScanSAR Mode			
Image Size Range×Azimuth	Number of Pixels & Data Volume [MB]		
	Pixel Spacing : 25m		
	Range	Azimuth	Data Volume [MB]
350×350 km	14000	14000	374
490×350 km	19600	14000	523

\* Data Volume shows the value for single polarization.

**Table 2.2-20 Level 1.5/3.1 Image Size and Volume for High-sensitive Mode  
(Full (Quad.) Polarization) (Geo-reference)**

High-sensitive Mode (Full (Quad.) pol.)			
Image Size Range×Azimuth	Number of Pixels & Data Volume [MB]		
	Pixel Spacing : 3.125m		
	Range	Azimuth	Data Volume [MB]
50×70 km	16000	22400	684

\* Data Volume shows the value for single polarization.

**Table 2.2-21 Level 1.5/3.1 Image Size and Volume for Fine Mode (Full (Quad.) Polarization)  
(Geo-reference)**

Fine Mode (Full (Quad.) Polarization)			
Image Size Range×Azimuth	Number of Pixels & Data Volume [MB]		
	Pixel Spacing : 6.25m (2 looks)		
	Range	Azimuth	Data Volume [MB]
30×70 km	4800	11200	103

\* Data Volume shows the value for single polarization.

### 2.3. Format

ALOS-2 CEOS level 1.1/1.5/3.1 data is based on the CEOS superstructure formats and consists of following files: Volume Directory File, SAR Leader File, SAR Image File and SAR Trailer File.

### 2.4. Product Description

In the case of multi-polarization data (i.e. Dual pol. and Full (Quad.) pol. data), the image data of ALOS-2 CEOS level 1.1/1.5/3.1 is divided in each polarization.

In the case of ScanSAR mode data, the level 1.1 image data is divided in each scan and the level 1.5/3.1 data is not divided in each scan.

The SAR Image file composition of CEOS level 1.1/1.5/3.1 for each observation mode is shown in Table 2.4-1.

**Table 2.4-1 SAR Image File Composition of CEOS Level 1.1/1.5/3.1 for Each Observation Mode**

Observation Mode	Polarization	Processing Level	Number of Data Files	Data File Composition
Spotlight	Single Pol. (HH, HV, VH or VV *1)	1.1/1.5/3.1	1	Data of HH, HV, VH or VV Polarization
Ultra-Fine, High-sensitive and Fine	Single Pol. (HH, HV, VH or VV)	1.1/1.5/3.1	1	Data of HH, HV, VH or VV Polarization
	Dual Pol. (HH+HV or VH+VV)	1.1/1.5/3.1	2	Data of HH+HV Polarization, or VH+VV Polarization
	Full Pol. (HH+HV+VH+VV)	1.1/1.5/3.1	4	Data of HH, HV, VH and VV Polarization
ScanSAR nominal and wide	Single Pol. (HH, HV, VH or VV)	1.1	5 or 7 *3, *4	Each scan data of HH, HV, VH or VV Polarization *3, *4 Storage methods vary depending on processing methods. (*5).
		1.5/3.1	1	First scan data Second scan data ..... Fifth scan data ..... Seventh scan data *4 of HH, HV, VH or VV Polarization
	Dual Pol. (HH+HV or VH+VV)	1.1	10 or 14 *3, *4	Each scan data of HH, HV, VH or VV Polarization *3, *4 Storage methods vary depending on processing methods. (*5).
		1.5/3.1	2	First scan data Second scan data ..... Fifth scan data ..... Seventh scan data *4 of HH, HV, VH or VV Polarization

\*1 The order of transmitting, receiving polarization.

\*2 (Erased)

\*3 The number of data files is the number of scans multiplied by the number of polarizations.

\*4 In the case of ScanSAR nominal and wide mode, the number of scans is 5 or 7, respectively.

\*5 See also chapter 5.2 “ Image File of ScanSAR Level 1.1 Product”.



## 2.5. Processing Parameter

Table 2.5-1 shows the processing parameters of each level.

**Table 2.5-1 Processing Parameter**

Parameter	Processing Level		
	1.0	1.1	1.5/3.1
Map Projection	-	-	UTM, PS, MER, LCC
Framing	-	-	Geo-reference Geo-coded
Image Direction *1	-	-	Map
Resampling Method	-	-	NN, BL, CC
Geodetic coordinate	-	-	ITRF97
Ellipsoid	-	-	GRS80
Scene Shift *2	-5 to 4 (-25 to 20)	-5 to 4 (-25 to 20)	-5 to 4 (-25 to 20)
Window Function	-	Rectangle	Rectangle
Number of Multi-look	-	1	Depending on observation mode
Pixel Spacing	-	-	depending on observation mode and multi-look number

\*1 Geocoded Product Only.

\*2 In the case of ScanSAR mode, the values in the brackets are available.

### 3. Product Formats

#### 3.1. Composition of CEOS Product

The overall configuration of CEOS level 1.1/1.5/3.1 product formats is shown in section 2.3. The definition of each file is shown in Table 3.1-1. And the file structure of each polarization is represented in Figure 3.1-1 to Figure 3.1-5.

|A

**Table 3.1-1 CEOS L1.1/1.5/3.1 File Composition and Definitions of File Names**

File Name	File Num.	Definition of File Name	Record name	Contents
Volume Directory File	1	VOL-Scene ID-Product ID	Volume descriptor File pointer Text	This file is located at the beginning of the image volume and stores the volume and file management information.
SAR Leader File	1	LED-Scene ID-Product ID	File descriptor Data set summary Map projection data (Only L1.5/3.1) Platform position data Attitude data Radiometric data Data quality summary Facility related data	This file is located before image file and stores annotation data, ancillary data and other types of data related to the image data in the succeeding image file.
SAR Image File (for level 1.1 of Scan SAR mode)	n (Number of polarization × Number of Scan)	IMG-XX-Scene ID-Product ID -Scan Information	File descriptor Signal data	This file is located after the leader file and stores the image data.
SAR Image File (except level 1.1 of Scan SAR mode)	n (Number of polarization)	IMG-XX-Scene ID-Product ID	File descriptor Signal data (Only L1.1) Processed data record (Only L1.5/3.1)	This file is located after the leader file and stores the image data.
SAR Trailer File	1	TRL-Scene ID-Product ID	File descriptor Low resolution image data	This file is located after the image file and stores the final information related to the image data.

Scene ID = AAAAABBBBBBCCCC-YYMMDD

AAAAA : Satellite/Sensor name (ALOS2)

BBBBB : Orbit accumulation number of a scene center

CCCC : Scene frame number of a scene center

-: separator

YYMMDD: Observation date of scene center (YY: lower 2 figures of a year, MM: month, DD: day)

Product ID = DDDEFFFGHI

DDD: Observation Mode

SBS: Spotlight mode

UBS: Ultra-fine mode Single polarization

UBD: Ultra-fine mode Dual polarization

HBS: High-sensitive mode Single polarization  
HBD: High-sensitive mode Dual polarization  
HBQ: High-sensitive mode Full (Quad.) polarimetry  
FBS: Fine mode Single polarization  
FBD: Fine mode Dual polarization  
FBQ: Fine mode Full (Quad.) polarimetry  
WBS: Scan SAR nominal [14MHz] mode Single polarization  
WBD: Scan SAR nominal [14MHz] mode Dual polarization  
WWS: Scan SAR nominal [28MHz] mode Single polarization  
WWD: Scan SAR nominal [28MHz] mode Dual polarization  
VBS: Scan SAR wide mode Single polarization  
VBD: Scan SAR wide mode Dual polarization

E: Observation Direction

L: Left looking, R: Right looking

FFF: Processing Level

1.0: Level 1.0

1.1: Level 1.1, 1.5: Level 1.5

3.1: Level 3.1

G: Processing Option

G: Geo-code, R: Geo-Reference, \_(underscore): Not Specified

H: Map Projection

U: UTM, P: PS, M: MER, L: LCC, \_(underscore): Not Specified

I: Orbit Direction

A: Ascending, D: Descending

Polarization (Transmission and Receiving) = XX

HH: Horizontally polarized wave transmission / Horizontally polarized wave receiving

HV: Horizontally polarized wave transmission / Vertically polarized wave receiving

VH: Vertically polarized wave transmission / Horizontally polarized wave receiving

VV: Vertically polarized wave transmission / Vertically polarized wave receiving

Scan information with Scan SAR level 1.1 Image data = XN

X: Processing method\*

F: Full aperture method

B: SPECAN method

N: Scan number

350km: 1 to 5,

490km: 1 to 7

\* Processing method

Full aperture method

Range compression and one look azimuth compression are performed for the data whose gaps between neighboring bursts in a sub swath are filled with zero.

This processing is performed for each scan and each polarization.

SPECAN method

Range compression and one look azimuth compression are performed for each burst.

Signal data is generated for each burst and stored in the order of the time series in the case of data of the same polarization in a sub swath.

■Single polarization (except Scan SAR level 1.1)

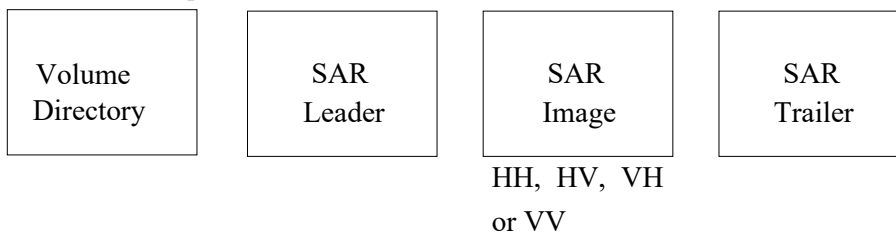

**Figure 3.1-1 CEOS level 1.1(except Scan SAR)/1.5/3.1 file composition/Single polarization** |A

■Single polarization (Scan SAR level 1.1)

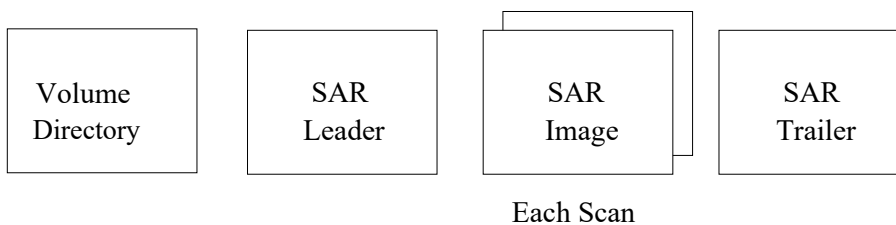

**Figure 3.1-2 CEOS Level 1.1(Scan SAR) file composition/Single polarization** |A

■Dual polarization (except Scan SAR level 1.1 )

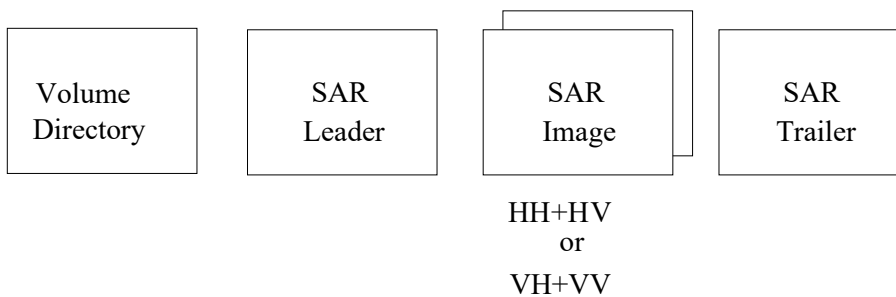

**Figure 3.1-3 CEOS level 1.1(except Scan SAR mode)/1.5/3.1 file composition/Dual polarization** |A

■Dual polarization (Scan SAR level1.1)

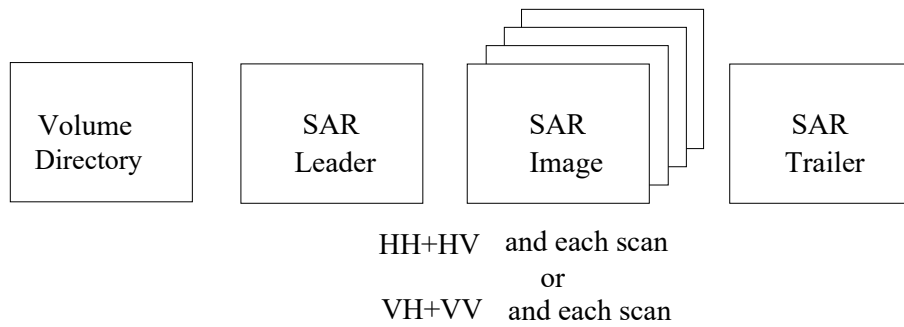

Figure 3.1-4 CEOS level 1.1(Scan SAR)/1.5/3.1 file composition/Dual polarization

|A

■High-sensitive/Fine Mode Full (Quad.) Polarimetry

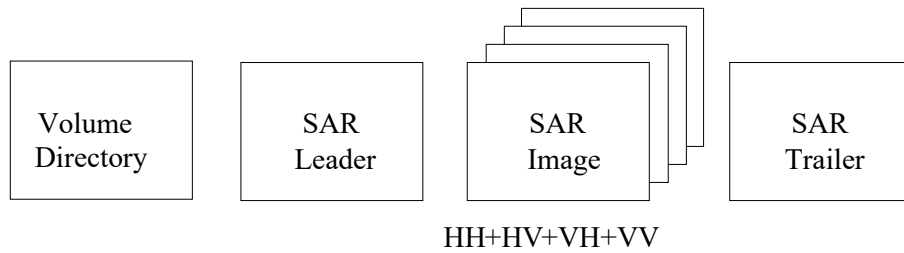

Figure 3.1-5 CEOS level 1.1/1.5/3.1 file composition/Full (Quad.) Polarimetry

|A

### 3.2. Record Structure of CEOS Product

The record structure of CEOS level 1.1/1.5/3.1 format is shown in Table 3.2-1. The sizes of the signal data record and the processed data record are shown in Table 3.3-14 and Table 3.3-15



**Table 3.2-1 Record Structure of CEOS level 1.1/1.5/3.1 Format**

Record No.		Record length [byte]	Number of records	Record name	File name
L1.1	L1.5/3.1				
1		360	1	Volume descriptor	Volume Directory
ScanSAR L1.1: 2 to 3 + number of polarizations x number of scans Except ScanSAR L1.1: 2 to 3 + number of polarizations		360	ScanSAR L1.1: Number of polarizations x number of scans + 2 Except ScanSAR L1.1: Number of polarizations + 2	File pointer	
ScanSAR L1.1: 4 + number of polarizations x number of scans Except ScanSAR L1.1: 4 + number of polarizations		360	1	Text	
1		720	1	File descriptor	SAR Leader
2		4,096	1	Data set summary	
-	3	1620	1	Map projection data (L1.5/3.1)	
3	4	4,680	1	Platform position data	
4	5	16,384	1	Altitude data	
5	6	9,860	1	Radiometric data	
6	7	1,620	1	Data quality summary	
7	8	325,000	1	Facility related data 1 (Dummy data)	
8	9	511,000	1	Facility related data 2 (Determined ephemeris)	
9	10	3,072	1	Facility related data 3 (Time error information)	
10	11	728,000	1	Facility related data 4 (Coordinate conversion information)	
11	12	5000	1	Facility related data 5 (Latitude and longitude conversion factor)	
1		720	1	File descriptor	SAR Image
2 to n+1		variable Variable	n n	Signal data (Only L1.1) Processed data (L1.5/3.1)	
1		720	1	File descriptor	SAR Trailer
ScanSAR L1.1: 2 to number of scans + 1 Except ScanSAR L1.1: 2		Variable	Scan SAR L1.1: Number of scans Except Scan SAR L1.1: 1	Low resolution image data	

A

### 3.2.1. Record Data Type

The definition of data type that used for description of record is shown in Table 3.2-2.

**Table 3.2-2 Definition of Data Types**

Type (code)	Details
Am	Character (Left-fill if not specified)
Im	ASCII that represents integer (Right-fill)
Fm.n	Real type data (Right-fill)
Em.n	Real type data (Exponential notation, right-fill)
Bm	Binary number representation (The first byte is the most significant, big endian)

m: Number of digits

n: Number of decimal places

p: multiplier in an index

### 3.2.2. Record Type Code and Record Sub-type Code

Each record has record type code and record sub-type code (sub-type code) in order to distinguish each other. The type code of each record is shown in Table 3.2-3 and Table 3.2-4.

**Table 3.2-3 Record Type of Each Record**

Record name	1 <sup>st</sup> record Sub-type	Record Type	2 <sup>nd</sup> record Sub-type	3 <sup>rd</sup> record Sub-type	Record length [byte]
Volume Descriptor	192	192	18	18	360
File pointer	219	192	18	18	360
Text	18	192	18	18	360
SAR Leader file Descriptor	11	192	18	18	720
Data set summary	18	10	18	20	4,096
Map projection data	18	20	18	10	1,620
Platform position data	18	30	18	20	4,680
Attitude data	18	40	18	20	16,384
Radiometric data	18	50	18	20	9,860
Data quality summary	18	60	18	20	1,620
Facility related data	18	200	18	70	Refer to Table 3.2-4
SAR data file Descriptor	50	192	18	18	720
Signal data	50	10	18	20	Refer to Table 3.3-14
Processed data	50	11	18	20	Refer to Table 3.3-15
SAR Trailer file Descriptor	63	192	18	18	720
Low resolution image data	-	-	-	-	Refer to Table 3.3-17

\* Value is decimal

**Table 3.2-4 Facility Related Data Record Type**

Record name	1 <sup>st</sup> record Sub-type	Record Type	2 <sup>nd</sup> record sub-type	3 <sup>rd</sup> record sub-type	Record length [byte]
Facility related 1 (Dummy data)	18	200	18	70	325,000
Facility related 2 (Determined ephemeris)					511,000
Facility related 3 (Time error information)					3,072
Facility related 4 (Coordinate conversion information)					728,000
Facility related 5 (Latitude and longitude conversion factor)					5000

A

\* Value is decimal

### 3.3. Contents of Records in CEOS Files

The record formats are shown in Table 3.3-1 to Table 3.3-17. "b" in a table means blanks. In the case of "N)<sub>10</sub>", "N" means decimal value. The definitions of items in CEOS level 1.1/1.5/3.1 format are shown in Table 3.3-18. The relationships between antenna beam number and parameters for each mode are shown in Table 3.3-19 to Table 3.3-27. | A

**Table 3.3-1 Volume descriptor records (1/2)**

Field No.	Byte No.	Type	Description	Remarks
1	1 - 4	B4	Record sequence number = 1) <sub>10</sub>	0000001h
2	5 - 5	B1	1 <sup>st</sup> record subtype code = 192) <sub>10</sub>	C0h
3	6 - 6	B1	Record type code = 192) <sub>10</sub>	C0h
4	7 - 7	B1	2 <sup>nd</sup> record subtype code = 18) <sub>10</sub>	12h
5	8 - 8	B1	3 <sup>rd</sup> record subtype code = 18) <sub>10</sub>	12h
6	9 - 12	B4	Length of this record = 360) <sub>10</sub>	00000168h
7	13 - 14	A2	ASCII/EBCDIC flag = 'Ab': ASCII	Ab
8	15 - 16	A2	Blanks	bb
9	17 - 28	A12	Superstructure format control document ID = 'CEOS-SARbbbb'	CEOS-SAR
10	29 - 30	A2	Superstructure format control document revision level = 'NN' NN: 'bA'~'bZ'	bA
11	31 - 32	A2	Superstructure record format revision level = 'NN' NN: 'bA'~'bZ'	bA
12	33 - 44	A12	Software release and revision level = 'NNN.NNNbbbb' 001.000, 001.001, ... 001.100, ... 002.000	001.000bbbb
13	45 - 60	A16	Physical volume ID Spacecraft Control Mission Operation system = 'SCMObbbbbbbbbb' Earth Intelligence Collection and Shearing System = 'EICSbbbbbbbbbb'	SCMObbbbbbbbbb
14	61 - 76	A16	Logical volume ID = 'MMNSSSYYYYMMDDbb' MM : Mission ID (ALOS2='AL')(*) N : Mission Number (=2')(*) SSS : Sensor ID (SAR='SAR')(*) YYYY : Product generation year MM : Product generation month DD : Product generation day	AL2SAR20150101bb
15	77 - 92	A16	Volume set ID = 'MMMMMMbSSSbbbbbb' MMMMMM : Mission name (ALOS2='ALOS2b') SSS : Sensor name (SAR='SAR')	ALOS2bbSARbbbbbb
16	93 - 94	I2	Total number of physical volumes in the logical volume = 'b1'	b1
17	95 - 96	I2	Physical volume sequence number of the first tape = 'b1'	b1

A

**Table 3.3-1 Volume descriptor records (2/2)**

Field No.	Byte No.	Type	Description	Remarks
18	97 - 98	I2	Physical volume sequence number of the last tape = 'b1'	b1
19	99 - 100	I2	Physical volume sequence number of the current tape = 'b1'	b1
20	101 - 104	I4	File number in the logical volume follows volume directory file. = 'bbb3'~'bbb6': N+2 (N is number of polarization) (Leader, Image, Trailer)	bbb3
21	105 - 108	I4	Logical volume within a volume set = 'bbb1'	bbb1
22	109 - 112	I4	Logical volume number within physical volume = 'bbb1'	bbb1
23	113 - 120	A8	Logical volume creation data = 'YYYYMMDD'(Without zero suppression) YYYY : Year MM : Month DD : Day	20150101
24	121 - 128	A8	Logical volume creation time = 'HHMMSSXX'(Without zero suppression) HH : Hour MM : Minute SS : Second XX : 10mili-second	12010100
25	129 - 140	A12	Logical volume generation country (JAPAN) = 'JAPANbbbbbbb'	JAPANbbbbbbb
26	141 - 148	A8	Logical volume generating agency (Japan Aerospace Exploration Agency) = 'JAXAbbbb'	JAXAbbbb
27	149 - 160	A12	Logical volume generating facility Spacecraft Control and Mission Operation System = 'SCMObbbbbbb' Earth Intelligence Collection and Shearing Earth Intelligence Collection and Shearing System = 'EICSbbbbbbb'	SCMObbbbbbb
28	161 - 164	I4	Number of file pointer records in volume directory Scan SAR and L1.1 = ' N+2 (N is number of polarization)' Except Scan SAR and L1.1 = ' N+2 (N is number of polarization)'	bbb3
29	165 - 168	I4	Number of text records in volume directory = 'bbb1'	bbb1
30	169 - 260	A92	Volume descriptor Spare = Blanks	Blanks (b*92)
31	261 - 360	A100	Local use segment = Blanks	Blanks (b*100)

**Table 3.3-2 File pointer records (1/3)**

Field No.	Byte No.	Type	Description	Remarks	
1	1 - 4	B4	Record number (Except Scan SAR L1.1) Single Polarization Leader file = 2) <sub>10</sub> Image file = 3) <sub>10</sub> Trailer file = 4) <sub>10</sub> Dual polarization Leader file = 2) <sub>10</sub> Image file = 3), 4) <sub>10</sub> Trailer file = 5) <sub>10</sub> Full (Quad.) polarimetry(four polarization) Leader file = 2) <sub>10</sub> Image file = 3), 4), 5), 6) <sub>10</sub> Trailer file = 7) <sub>10</sub>	Record number (Scan SAR L1.1) Single Polarization 350km Leader file = 2) <sub>10</sub> Image file = 3) <sub>10</sub> to 7) <sub>10</sub> Trailer file = 8) <sub>10</sub> Single Polarization 490km Leader file = 2) <sub>10</sub> Image file = 3) <sub>10</sub> to 9) <sub>10</sub> Trailer file = 10) <sub>10</sub> Dual polarization 350km Leader file = 2) <sub>10</sub> Image file = 3) <sub>10</sub> to 12) <sub>10</sub> Trailer file = 13) <sub>10</sub> Dual polarization 490km Leader file = 2) <sub>10</sub> Image file = 3) <sub>10</sub> to 16) <sub>10</sub> Trailer file = 17) <sub>10</sub>	
2	5 - 5	B1	1 <sup>st</sup> record Sub-type code = 219) <sub>10</sub>	DBh	
3	6 - 6	B1	Record type code = 192) <sub>10</sub>	C0h	
4	7 - 7	B1	2 <sup>nd</sup> sub-type code = 18) <sub>10</sub>	12h	
5	8 - 8	B1	3 <sup>rd</sup> sub-type code = 18) <sub>10</sub>	12h	
6	9 - 12	B4	Record length = 360) <sub>10</sub>	00000168h	
7	13 - 14	A2	ASCII/EBCDIC code = 'Ab': ASCII	Ab	
8	15 - 16	A2	Blanks	bb	
9	17 - 20	I4	Referenced file number Leader file = 'bbb1' Image file = 'bbb2' Trailer file = 'bbb3'	bbb1	

A



**Table 3.3-2 File pointer records (2/3)**

Field No.	Byte No.	Type	Description	Remarks
10	21 - 36	A16	Referenced File name ID = 'MMN <b>b</b> SSST <b>FFFF</b> bbbb' MM : Mission ID (ALOS2='AL')(*) N : Mission number (=2')(*) SSS : Sensor ID (SAR='SAR')(*) T : Processing level code Level 1.0 = 'A' Level 1.1 = 'B' Level 1.5 = 'C' Level 3.1 = 'D' FFFF : File Type(*) Leader file = 'SARL' Image file = 'IMOP' Trailer = 'SART'	AL2 <b>b</b> SARASARL <b>bbbb</b>
11	37 - 64	A28	Referenced file class Leader file = 'SARLEADER <b>b</b> FILE <b>bbbbbbbbbbbbbb</b> ' Image file = 'IMAGERY <b>b</b> OPTIONS <b>b</b> FILE <b>bbbbbbbb</b> ' Trailer file = 'SARTRAILER <b>b</b> FILE <b>bbbbbbbbbbbbbb</b> '	SARLEADER <b>b</b> FILE <b>bbbbbbbbbbbbbb</b>
12	65 - 68	A4	Reference file class code Leader file = 'SARL' Image file = 'IMOP' Trailer file = 'SART'	SARL
13	69 - 96	A28	Referenced file data Type = 'MIXED <b>b</b> BINARY <b>b</b> AND <b>b</b> ASCII <b>bbbbbb</b> '	MIXED <b>b</b> BINARY <b>b</b> AND <b>b</b> ASCII <b>bbbbbb</b>
14	97 - 100	A4	Referenced file data Type code = 'MBAA'(Mixed Binary And ASCII)	MBAA
15	101 - 108	I8	Number of records in referenced file Leader file = 'bbbbbb11': Level 1.1 'bbbbbb12': Level 1.5/3.1 Image file = N+1 (N is the number of image data records) Trailer file = N+1 (N is the number of Scan) : ScanSAR and Level 1.1 = 'bbbbbb2' : Other	bbbbbb15
16	109 - 116	I8	Length of the first record in referenced file = 'bbbbbb720'	bbbbbb720
17	117 - 124	I8	Maximum record length in referenced file	bbbbnnnn

C

**Table 3.3-2 File pointer records (3/3)**

Field No.	Byte No.	Type	Description	Remarks
18	125 - 136	A12	Referenced file record length type Leader file = 'VARIABLEbLEN' Image file = 'VARIABLEbLEN' Trailer file = 'VARIABLEbLEN'	VARIABLEbLEN
19	137 - 140	A4	Referenced file record length type code Leader file = 'VARE' Image file = 'VARE' Trailer file = 'VARE'	VARE
20	141 - 142	I2	The number of the physical volume set containing the first record of the file = 'b1'	b1
21	143 - 144	I2	The number of the physical volume set containing the last record of the file = 'b1'	b1
22	145 - 152	I8	Record number of the first record appearing on this physical volume = 'bbbbbb1'	bbbbbb1
23	153 - 160	I8	Record number of the last record appearing on this physical volume Leader file = 'bbbbbb11': Level 1.1 'bbbbbb12': Level 1.5/3.1 Image file = N+1 (N is the number of image data records) Trailer file = N+1 (N is the number of Scan) : ScanSAR and Level 1.1 = 'bbbbbb2' : Other	
24	161 - 260	A100	Spare = Blanks	Blanks (b*100)
25	261 - 360	A100	Local use segment = Blanks	Blanks (b*100)

C

**Table 3.3-3 Text records (1/3)**

Field No.	Byte No.	Type	Description	Remarks
1	1 - 4	B4	Record number Scan SAR and L1.1 = $N_1 \times N_2 + 4$ ) <sub>10</sub> ( $N_1$ = 'Number of polarization', $N_2$ = 'Number of scan') Except Scan SAR and L1.1 = $N + 4$ ) <sub>10</sub> ( $N$ = 'Number of polarization')	
2	5 - 5	B1	1 <sup>st</sup> record sub-type code = 18) <sub>10</sub>	12h
3	6 - 6	B1	Record type code = 192) <sub>10</sub>	C0h
4	7 - 7	B1	2 <sup>nd</sup> sub-type code = 18) <sub>10</sub>	12h
5	8 - 8	B1	3 <sup>rd</sup> sub-type code = 18) <sub>10</sub>	12h
6	9 - 12	B4	Record length = 360) <sub>10</sub>	00000168h
7	13 - 14	A2	ASCII/EBCDIC code = 'Ab': ASCII	Ab
8	15 - 16	A2	Blanks	bb
9	17 - 56	A40	Product ID = 'PRODUCT: DDDEFFFGHIbbbbbbbbbbbbbbbbbbbb' DDD: Observation mode (*) SBS: Spotlight mode UBS: Ultra-fine mode (Single pol.) UBD: Ultra-fine mode (Dual pol.) HBS: High-sensitive mode (Single pol.) HBD: High-sensitive mode (Dual pol.) HBQ: High-sensitive mode (Full(Quad.) pol.) FBS: Fine mode (Single pol.) FBD: Fine mode (Dual pol.) FBQ: Fine mode (Full (Quad.) pol.) WBS: ScanSAR nominal [14MHz] mode (Single pol.) WBD: ScanSAR nominal [14MHz] mode (Dual pol.) WWS: ScanSR nominal [28MHz,] mode (Single pol.) WWD: ScanSAR nominal [28MHz] mode (Dual pol.) VBS: ScanSAR wide mode (Single pol.) VBD: ScanSAR wide mode (Dual pol.) E : Observation direction (*) L: Left looking R: Right looking	PRODUCT: HSPR1.0_UAbbbbbbbbbbb bbbbbbbbbb Refer to Table 4.3-1 No.1

**Table 3.3-3 Text records (2/3)**

Field No.	Byte No.	Type	Description	Remarks
			FFF: Processing level 1.0: Level 1.0 1.1: Level 1.1 1.5: Level 1.5 3.1: Level 3.1 G : Processing option G: Geo-Coded R: Geo-Reference _ : Not specified (Underscore) H : Map projection U: UTM P: PS M: MER L: LCC _ : Not specified (Underscore) I : Orbit direction (*) A: Ascending D: Descending	
10	57 - 116	A60	Location and date/time of product creation Spacecraft Control Mission Operation system = 'PROCESS: JAPAN-JAXA-ALOS2-SCMObbYYYYMMDDbHHMMSSb...b' Earth Intelligence Collection and Shearing system = 'PROCESS: JAPAN-JAXA-ALOS2-EICSbbYYYYMMDDbHHMMSSb...b' (without zero suppress both) YYYYMMDD : Date of creation (YYYY: Year, MM: Month, DD: Day) HHMMSS : Time of Creation (UTC)	
11	117 - 156	A40	Physical tape ID = 'TAPEbID: bbbbbb'	TAPEbID: bbbbbb bbbbbb

**Table 3.3-3 Text records (3/3)**

Field No.	Byte No.	Type	Description	Remarks
12	157 - 196	A40	Scene ID = 'ORBITb: AAAAABBBBBBCCCC-YYMMDDbbbbbbbbbbb' AAAAA : Satellite (= 'ALOS2') BBBBB : Orbit accumulation number of a scene center CCCC : Scene frame number of a scene center - : Separator (hyphen) YYMMDD : Observation date of a scene center (YY: lower 2 figures of a year, MM: month, DD: day)	ORBITb: ALOS2000010001-150101bbbbbb bbbbbb Refer to Table 3.3-18 No.2.
13	197 - 236	A40	Scene location ID = 'FRAMEbCENTRE: bbbbbbbbbbbbbbbbbbbbbbb' : Level 1.1 = 'FRAMEbCENTRE: bN±nnn.nnbbE±nnn.nnbbbbbbb' : Level 1.5/3.1 N±nnn.nn : Latitude of a scene center [deg] E±nnn.nn : Longitude of a scene center [deg]	In the case of level 1.1 FRAMEbCENTRE: bbbbbbbbbbbbbbbbbbbbbbb
14	237 - 360	A124	Blanks	Blanks (b*124)

**Table 3.3-4 SAR Leader file descriptor records (1/4)**

Field No.	Byte No.	Type	Description	Remarks
1	1 - 4	B4	Record number = 1) <sub>10</sub>	0000001h
2	5 - 5	B1	1 <sup>st</sup> record sub-type code = 11) <sub>10</sub>	0Bh
3	6 - 6	B1	Record type code = 192) <sub>10</sub>	C0h
4	7 - 7	B1	2 <sup>nd</sup> sub-type code = 18) <sub>10</sub>	12h
5	8 - 8	B1	3 <sup>rd</sup> sub-type code = 18) <sub>10</sub>	12h
6	9 - 12	B4	Record length = 720) <sub>10</sub>	000002D0h
7	13 - 14	A2	ASCII/EBCDIC code = 'Ab': ASCII	Ab
8	15 - 16	A2	Blanks	bb
9	17 - 28	A12	Format control document ID = 'CEOS-SARbbbb'	CEOS-SARbbbb
10	29 - 30	A2	Format control document revision level = 'bA'	bA
11	31 - 32	A2	Record format revision level = 'bA'	bA
12	33 - 44	A12	Software release and revision number = 'NNN.NNNbbbb' 001.000, 001.001, ... 001.100, ... 002.000	001.000bbbb
13	45 - 48	I4	File number = 'bbb1'	bbb1
14	49 - 64	A16	File ID = 'MMNbSSSTFFFFbbbb' MM : Mission ID (ALOS2='AL')(*) N : Mission number (=2')(*) SSS : Sensor ID (SAR='SAR')(*) T : Processing level code Level 1.0 = 'A' Level 1.1 = 'B' Level 1.5 = 'C' Level 3.1 = 'D' FFFF : File Type(*) Leader file = 'SARL' Image file = 'IMOP' Trailer file = 'SART'	AL2bSARASARLbbbb
15	65 - 68	A4	Record sequence and location type flag = 'FSEQ'	FSEQ

A

**Table 3.3-4 SAR Leader file descriptor records (2/4)**

Field No.	Byte No.	Type	Description	Remarks
16	69 - 76	I8	Sequence number of location = 'bbbbbb1'	bbbbbb1 (Location of record No.)
17	77 - 80	I4	Field length of sequence number = 'bbb4'	bbb4 (Field length of record No.)
18	81 - 84	A4	Record code and location type flag = 'FTYP'	FTYP
19	85 - 92	I8	Location of record code = 'bbbbbb5'	bbbbbb5
20	93 - 96	I4	Field length of record code = 'bbb4'	bbb4
21	97 - 100	A4	Record length and location type flag = 'FLGT'	FLGT
22	101 - 108	I8	Location of record length = 'bbbbbb9'	bbbbbb9
23	109 - 112	I4	Field length of record length = 'bbb4'	bbb4
24	113 - 180	A68	Blanks	Blanks (b*68)
25	181 - 186	I6	Number of data set summary records = 'bbbb1'	bbbb1
26	187 - 192	I6	Data set summary record length = 'bb4096'	bb4096
27	193 - 198	I6	Number of map projection data records = 'bbbb0': Level 1.1 = 'bbbb1': Level 1.5/3.1	
28	199 - 204	I6	Map projection data record length = 'bbbb0': Level 1.1 = 'bb1620': Level 1.5/3.1	
29	205 - 210	I6	Number of platform position data records = 'bbbb1'	bbbb1
30	211 - 216	I6	Platform position record length = 'bb4680'	bb4680
31	217 - 222	I6	Number of attitude data records = 'bbbb1'	bbbb1
32	223 - 228	I6	Attitude data record length = 'b16384'	b16384
33	229 - 234	I6	Number of radiometric data records = 'bbbb1'	
34	235 - 240	I6	Radiometric record length = 'bb9860'	
35	241 - 246	I6	Number of radiometric compensation records = 'bbbb0'	bbbb0
36	247 - 252	I6	Radiometric compensation record length = 'bbbb0'	bbbb0
37	253 - 258	I6	Number of data quality summary records = 'bbbb1'	
38	259 - 264	I6	Data quality summary record length = 'bb1620'	
39	265 - 270	I6	Number of data histograms records = 'bbbb0'	bbbb0
40	271 - 276	I6	Data histogram record length = 'bbbb0'	bbbb0

**Table 3.3-4 SAR Leader file descriptor records (3/4)**

Field No.	Byte No.	Type	Description	Remarks
41	277 - 282	I6	Number of range spectra records = 'bbbbbb0'	bbbbbb0
42	283 - 288	I6	Range spectra record length = 'bbbbbb0'	bbbbbb0
43	289 - 294	I6	Number of DEM descriptor records = 'bbbbbb0'	bbbbbb0
44	295 - 300	I6	DEM descriptor record length = 'bbbbbb0'	bbbbbb0
45	301 - 306	I6	Number of radar parameter update records = 'bbbbbb0'	bbbbbb0
46	307 - 312	I6	Radar parameter update record length = 'bbbbbb0'	bbbbbb0
47	313 - 318	I6	Number of annotation data records = 'bbbbbb0'	bbbbbb0
48	319 - 324	I6	Annotation data record length = 'bbbbbb0'	bbbbbb0
49	325 - 330	I6	Number of detail processing records = 'bbbbbb0'	bbbbbb0
50	331 - 336	I6	Detail processing record length = 'bbbbbb0'	bbbbbb0
51	337 - 342	I6	Number of calibration records = 'bbbbbb0'	
52	343 - 348	I6	Calibration record length = 'bbbbbb0'	
53	349 - 354	I6	Number of GCP records = 'bbbbbb0'	bbbbbb0
54	355 - 360	I6	GCP record length = 'bbbbbb0'	bbbbbb0
55	361 - 420	10A6	Spare	Blanks(b*A58)
56	421 - 426	I6	Number of facility data(1) records = 'bbbbbb1'	bbbbbb1
57	427 - 434	I8	Facility data(1) record length = 'bb325000'	bb325000
58	435 - 440	I6	Number of facility data(1) records = 'bbbbbb1'	bbbbbb1
59	441 - 448	I8	Facility data(2) record length = 'bb511000'	bb511000
60	449 - 454	I6	Number of facility data(2) records = 'bbbbbb1'	bbbbbb1
61	455 - 462	I8	Facility data(3) record length = 'bbbb3072'	bbbb3072
62	463 - 468	I6	Number of facility data(3) records = 'bbbbbb1'	bbbbbb1
63	469 - 476	I8	Facility data(4) record length = 'bb728000'	bb728000



**Table 3.3-4 SAR Leader file descriptor records (4/4)**

Field No.	Byte No.	Type	Description	Remarks
64	477 - 482	I6	Number of facility data(5) records = 'bbbb1'	
65	483 - 490	I8	Facility data(5) record length = 'bbb5000'	
66	491 - 720	A230	Blanks	

**Table 3.3-5 Data set summary records (1/16)**

Field No.	Byte No.	Type	Description	Remarks
1	1 - 4	B4	Records number = 2) <sub>10</sub>	00000002h
2	5 - 5	B1	1 <sup>st</sup> record sub-type code = 18) <sub>10</sub>	12h
3	6 - 6	B1	Record type code = 10) <sub>10</sub>	0Ah
4	7 - 7	B1	2 <sup>nd</sup> record sub-type code = 18) <sub>10</sub>	12h
5	8 - 8	B1	3 <sup>rd</sup> record sub-type code = 20) <sub>10</sub>	14h
6	9 - 12	B4	Data set summary records length = 4096) <sub>10</sub>	00001000h
7	13 - 16	I4	Data set summary records sequence number = 'bbb1'	bbb1
8	17 - 20	A4	SAR channel ID = Blanks (fixed value)	bbbb
9	21 - 52	A32	Scene ID = 'AAAAABBBBBBCCCC-YYMMDDbbbbbbbbbbb' AAAAA : Satellite ID (=ALOS2) BBBBB : Orbit accumulation number of a scene center CCCC : Scene frame number of a scene center - : Separator (hyphen) YYMMDD : Observation date of a scene center (YY: lower 2 figures of a year, MM: month, DD: day)	ALOS2000010001-150101bbbbbbbbbbb Refer to Table 3.3-18 No.2
10	53 - 68	A16	Number of scene reference = Blanks (fixed value)	bbbbbbbbbbbbbbbb
11	69 - 100	A32	Scene center time = 'YYYYMMDDHHMMSStttbbbbbbbbbbbbbbb' (Without zero suppression, YYYY: year, MM: month , DD: day) HHMMSSttt : Time (UTC)	In the case of level 1.1 20150101120000000bbbbbbbbbbbbbbb
12	101 - 116	A16	Spare = Blanks (fixed value)	bbbbbbbbbbbbbbbb
13	117 - 132	F16.7	Geodetic latitude (defined as positive to the north of the equator and negative to the south) of processed scene center [deg] = Blanks: Level 1.1 = Positive value to the north of the equator : Level 1.5/3.1 = Negative value to the south of the equator : Level 1.5/3.1	In the case of level 1.1 bbbbbbbbbbbbbbbb
14	133 - 148	F16.7	Geodetic longitude (defined as positive to the east of the prime meridian and negative to the west) of processed scene center [deg] = Blanks: Level 1.1 = Positive value to the east of the prime meridian: Level 1.5/3.1 = Positive value to the west of the prime meridian: Level 1.5/3.1	In the case of level 1.1 bbbbbbbbbbbbbbbb

**Table 3.3-5 Data set summary records (2/16)**

Field No.	Byte No.	Type	Description	Remarks
15	149 - 164	F16.7	Processed scene center true heading [deg] = Blanks: Level 1.1 = Value: Level 1.5/3.1	In the case of level 1.1 bbbbbbbbbbbbbbbb
16	165 - 180	A16	Ellipsoid designator = 'GRS80bbbbbbbbbb'(fixed value)	GRS80bbbbbbbbbb
17	181 - 196	F16.7	Ellipsoid semi-major axis [km] = 6378.1370000	
18	197 - 212	F16.7	Ellipsoid semi-minor axis [km] = 6356.7523141	
19	213 - 228	F16.7	Earth mass [10 <sup>24</sup> kg] = 5.9740000	
20	229 - 244	F16.7	Gravitational constant [10 <sup>-14</sup> m <sup>3</sup> /s <sup>2</sup> ] = 3.9860050	
21	245 - 260	F16.7	Ellipsoid J2 parameter = 0.1082629*10 <sup>-2</sup>	(Ellipsoid J2 parameter)
22	261 - 276	F16.7	Ellipsoid J3 parameter = -0.0000254*10 <sup>-1</sup>	(Ellipsoid J3 parameter)
23	277 - 292	F16.7	Ellipsoid J4 parameter = -0.0000162*10 <sup>-1</sup>	(Ellipsoid J4 parameter)
24	293 - 308	A16	Spare = Blanks(fixed value)	bbbbbbbbbbbbbbbb
25	309 - 324	F16.7	Average terrain height above ellipsoid at scene center = Blanks (fixed value)	bbbbbbbbbbbbbbbb
26	325 - 332	I8	Scene center line No. (Including zero fill)	N/2 (N: number of lines)
27	333 - 340	I8	Scene center pixel No. (Including zero fill)	M/2 (M: number of pixels)
28	341 - 356	F16.7	Processing scene length [km] = Blanks (fixed value)	bbbbbbbbbbbbbbbb
29	357 - 372	F16.7	Processed scene width [km] = Blanks (fixed value)	bbbbbbbbbbbbbbbb
30	373 - 388	A16	Spare = Blanks (fixed value)	bbbbbbbbbbbbbbbb
31	389 - 392	I4	Number of SAR channel = 'bbbn' Single Beam type 2: Fine [10m] mode (Single pol.) 4: Fine [10m] mode (Dual pol. and Full (Quad.) pol.) Dual beam type 4: Spotlight mode, High resolution mode (Single pol.), ScanSAR mode (Single pol.) 8: High resolution mode (Dual pol. and Full (Quad.) pol.) ScanSAR mode (Dual pol.)	bbb2
32	393 - 396	A4	Spare = Blanks (fixed value)	bbbb
33	397 - 412	A16	Sensor platform mission identifier (ID) = 'ALOS2bbbbbbbbbb'	ALOS2bbbbbbbbbb

**Table 3.3-5 Data set summary records (3/16)**

Field No.	Byte No.	Type	Description	Remarks
34	413 - 444	A32	Sensor ID and operation mode = 'AAAAAA-BB-CCDD-bbbbbbbbbbbbbbbb' AAAAAA : Satellite ID (= 'ALOS2b') BB : SAR band (= 'Lb') CC : Operation mode '00': Spotlight mode '01': Ultra-fine mode '02': High-sensitive mode '03': Fine mode '04': spare '05': spare '08': ScanSAR nominal mode '09': ScanSAR wide mode '18': Full (Quad.) pol./High-sensitive mode '19': Full (Quad.) pol./Fine mode '64': Manual observation Other: spare DD : Calibration mode '00': A/D offset before observation '01': A/D noise measure before observation '02': Pulse replica before observation '03': Range zero before observation '04': Pulse replica after observation '05': Range zero after observation '06': Noise measure after observation '14': Calibration in observation '15': During observation Other: spare	ALOS2b-Lb-015-bbbbbbbbbbbb bbbbbb

A

**Table 3.3-5 Data set summary records (4/16)**

Field No.	Byte No.	Type	Description	Remarks
35	445 - 452	I8	Orbit number or flight line indicator	bbbbbb1
36	453 - 460	F8.3	Sensor platform geodetic latitude at nadir corresponding to scene center [deg] = Blanks: Level 1.1 = Value: Level 1.5/3.1	In the case of level 1.1 bbbbbbb
37	461 - 468	F8.3	Sensor platform geodetic longitude at nadir corresponding to scene center [deg] = Blanks: Level 1.1 = Value: Level 1.5/3.1	In the case of level 1.1 bbbbbbb
38	469 - 476	F8.3	Sensor platform heading at nadir corresponding to scene center [deg] = Blanks: Level 1.1 = Value: Level 1.5/3.1	In the case of level 1.1 bbbbbbb
39	477 - 484	F8.3	Sensor clock angle as measured relative to sensor platform flight direction [deg] Left = 'b-90.000' Right = 'bb90.000'	b-90.000
40	485 - 492	F8.3	Incidence angle at scene center [deg] = Value: Level 1.1 = Value: Level 1.5/3.1 Geo-reference = Nominal value: Level 1.5/3.1 Geo-coded	In level 1.5/3.1 Geo-coded (Incidence angle)
41	493 - 500	A8	Spare = Blanks	bbbbbbb
42	501 - 516	F16.7	Radar wavelength [m] = Nominal value	(Radar wavelength)
43	517 - 518	A2	Motion compensation indicator = '00'(Always '00') 00 : No. compensation 01 : on board compensation 10 : in processor compensation 11 : both on board and in processor	00
44	519 - 534	A16	Range pulse code = 'LINEARbFMbCHIRPb'	LINEARbFMbCHIRPb
45	535 - 550	E16.7	Range pulse amplitude coefficient #1 = Nominal value Center frequency $\xi_1$ for pulse width $\tau$ of linearFMmodulationchirp (Constant term)	(Range pulse amplitude coefficient #1)
46	551 - 566	E16.7	Range pulse amplitude coefficient #2 = Nominal value FMrate $\xi_2$ for pulse width $\tau$ of linearFMmodulationchirp (Linear coefficient terms)	(Range pulse amplitude coefficient #2)

**Table 3.3-5 Data set summary records (5/16)**

Field No.	Byte No.	Type	Description	Remarks
47	567 - 582	E16.7	Range pulse amplitude coefficient #3 = Nominal value (= 0.0) FMrate $\xi_3$ for pulse width $\tau$ of linearFMmodulationchirp (Quadratic coefficient terms)	(Range pulse amplitude coefficient #3)
48	583 - 598	E16.7	Range pulse amplitude coefficient #4 = Nominal value (= 0.0) FMrate $\xi_4$ for pulse width $\tau$ of linearFMmodulationchirp (Cubic coefficient terms)	(Range pulse amplitude coefficient #4)
49	599 - 614	E16.7	Range pulse amplitude coefficient #5 = Nominal value (= 0.0) FMrate $\xi_5$ for pulse width $\tau$ of linearFMmodulationchirp (Quartic term coefficient)	(Range pulse amplitude coefficient #5)
50	615 - 630	E16.7	Range pulse phase coefficient # 1 (Constant term) = Blanks (fixed value)	bbbbbbbbbbbbbb
51	631 - 646	E16.7	Range pulse phase coefficient # 2 (Linear coefficient terms) = Blanks (fixed value)	bbbbbbbbbbbbbb
52	647 - 662	E16.7	Range pulse phase coefficient # 3 (Quadratic coefficient terms) = Blanks (fixed value)	bbbbbbbbbbbbbb
53	663 - 678	E16.7	Range pulse phase coefficient # 4 (Cubic coefficient terms) = Blanks (fixed value)	bbbbbbbbbbbbbb
54	679 - 694	E16.7	Range pulse phase coefficient # 5 (Quartic term coefficient) = Blanks (fixed value)	bbbbbbbbbbbbbb
55	695 - 702	I8	Down linked data chirp extraction index linear-up chirp = 'bbbbbb0' linear-down chirp = 'bbbbbb1' linear-up and -down chirp = 'bbbbbb2'	
56	703 - 710	A8	Spare = Blanks	bbbbbbbb
57	711 - 726	F16.7	Sampling rate [MHz] Extracted from auxiliary data of first PALSAR frame	(Sampling rate) Refer to Table 3.3-18 No.3
58	727 - 742	F16.7	Range gate (early edge (in time) at the start of the image) [ $\mu$ sec] Extracted from auxiliary data of first PALSAR frame	(Range gate) Refer to Table 3.3-18 No.4
59	743 - 758	F16.7	Range pulse width [ $\mu$ sec] Extracted from auxiliary data of first PALSAR frame	(Range pulse width) Refer to Table 3.3-18 No.5
60	759 - 762	A4	Base band conversion flag = 'YESb' (Always 'YESb')	YESb Refer to Table 3.3-18 No.6
61	763 - 766	A4	Range compressed flag = 'YESb': Level 1.1 or later: range compressed (Always)	
62	767 - 782	F16.7	Receiver gain for like polarized at early edge at the start of the image = Nominal value	(Receiver gain for like polarized)
63	783 - 798	F16.7	Receiver gain for cross polarized at early edge at the start of the image = Nominal value	(Receiver gain for cross polarized)
64	799 - 806	I8	Quantization in bits per channel = 'bbbbbb8'	bbbbbb8
65	807 - 818	A12	quantized descriptor = 'UNIFORMbI,Qb'	UNIFORMbI,Qb
66	819 - 834	F16.7	DC Bias for I-component = Nominal value	(DC Bias for I-component)

**Table 3.3-5 Data set summary records (6/16)**

Field No.	Byte No.	Type	Description	Remarks
67	835 - 850	F16.7	DC Bias for Q-component = Nominal value	(DC Bias for Q-component)
68	851 - 866	F16.7	Gain imbalance for I & Q = Nominal value	(Gain imbalance for I & Q)
69	867 - 882	F16.7	Spare = Blanks (fixed value)	bbbbbbbbbbbbbb
70	883 - 898	F16.7	Spare = Blanks (fixed value)	bbbbbbbbbbbbbb
71	899 - 914	F16.7	electronic boresight = fixed value	Electronic boresight and mechanical boresight is the same definition (The same value)
72	915 - 930	F16.7	mechanical boresight = fixed value	Electronic boresight and mechanical boresight is the same definition (The same value)
73	931 - 934	A4	Echo tracker-on/off = 'OFFb' (fixed value)	OFFb ONOFF: Always 'OFF' on ALOS2
74	935 - 950	F16.7	PRF[mHz]	
75	951 - 966	F16.7	Two-way antenna beam width [deg] (Elevation, Effective value) = Nominal value	(Two-way antenna beam width elevation)
76	967 - 982	F16.7	Two-way antenna beam width [deg] (Azimuth, Effective value) = Nominal value	(Two-way antenna beam width azimuth)
77	983 - 998	I16	Satellite encoded binary time code: Standard satellite time counter of error time information (Tref)	(Standard satellite time of error time information) Refer to Table 3.3-18 No. 11
78	999 - 1030	A32	Satellite clock time: Standard ground time of error time information (Tgref)	(Standard ground time) Refer to Table 3.3-18 No. 12
79	1031 - 1046	I16	Satellite clock increment [nsec]: Error time information of calculation satellite counter cycle (Psc)	(Calculation satellite counter cycle) Refer to Table 3.3-18 No.13
80	1047 - 1062	A16	Processing facility ID Spacecraft Control Mission Operation system = 'SCMObbbbbbbbbb' Earth Intelligence Collection and Shearing System = 'EICSbbbbbbbbbb'	SCMObbbbbbbbbb
81	1063 - 1070	A8	Processing system ID Spacecraft Control Mission Operation System = 'SCMObbbb' Earth Intelligence Collection and Shearing System = 'EICSbbbb'	
82	1071 - 1078	A8	Processing version ID Note: This is the same as first 8 characters of software release and version ID for volume descriptor	NNN.NNNb
83	1079 - 1094	A16	Processing code of processing facility = Blanks (fixed value)	bbbbbbbbbbbbbb

A

**Table 3.3-5 Data set summary records (7/16)**

Field No.	Byte No.	Type	Description	Remarks
84	1095 - 1110	A16	Product level code = '1.1bbbbbbbbbbbb': Level 1.1 = '1.5bbbbbbbbbbbb': Level 1.5 = '3.1bbbbbbbbbbbb': Level 3.1	
85	1111 - 1142	A32	Product type specifier = 'BASICbIMAGEbbbbbbbbbbbbbbbb': Level 1.1 = 'STANDARDbGEOCODEDbIMAGEbbbbbbbb': Level 1.5 = 'CORRECTEDbGEOCODEDbIMAGEbbbbbbbb': Level 3.1	
86	1143 - 1174	A32	Processing algorithm ID = Blanks (fixed value)	bbbbbbbbbbbbbbbbbbbbbbbbbbbbbbbb bbbbbb
87	1175 - 1190	F16.7	Number of looks in azimuth Level 1.1 : 1.0 Level 1.5/3.1 : 2 (Fine [10m], Full (Quad.) pol. fine [10m]) 3 (ScanSAR [14MHz], ScanSAR [28MHz]) 1.5 (ScanSAR (490km)) 1 (Others)	The pixel spacing measured not on the reference ellipsoid but on map coordinates.
88	1191 - 1206	F16.7	Number of looks in range Level 1.1 : 1.0 Level 1.5/3.1 : 5 (ScanSAR [14MHz], ScanSAR [28MHz]) 2(ScanSAR (490km)) 1(Others)	
89	1207 - 1222	F16.7	Bandwidth per look in azimuth [Hz] Same value as 1239-1254 bytes	
90	1223 - 1238	F16.7	Bandwidth per look in range [Hz] 3dB down width of the power spectrum of the reference function for a sub aperture look	
91	1239 - 1254	F16.7	Bandwidth in azimuth [Hz] 3dB down width of power spectrum of the reference function for full aperture ScanSAR: Blanks	In ScanSAR: bbbbbbbbbbbbbbbb
92	1255 - 1270	F16.7	Bandwidth in range [kHz]	bbbbbbbbbbbbbbbb



**Table 3.3-5 Data set summary records (8/16)**

Field No.	Byte No.	Type	Description	Remarks
93	1271 - 1302	A32	Weighing function in azimuth = 'bbbbbbbbbbbbbbbbbbbbbbbbbbbb1': RECTANGLE	
94	1303 - 1334	A32	Weighing function in range = 'bbbbbbbbbbbbbbbbbbbbbbbbbb1': RECTANGLE	
95	1335 - 1350	A16	Data input source (e.g.HDDT-ID) = 'ONLINEbbbbbbbb': Online transfer (fixed value)	ONLINEbbbbbbbb
96	1351 - 1366	F16.7	Resolution in ground range [m] = Nominal value	In the case of level 1.1 bbbbbbbbbbbbbbbb
97	1367 - 1382	F16.7	Resolution in azimuth [m] = Nominal value	In the case of level 1.1 bbbbbbbbbbbbbbbb
98	1383 - 1398	F16.7	Radiometric parameter (Bias) = Blanks (fixed value)	bbbbbbbbbbbbbbbb
99	1399 - 1414	F16.7	Radiometric parameter (Gain) = Blanks (fixed value)	bbbbbbbbbbbbbbbb
100	1415 - 1430	F16.7	Along track Doppler frequency (center) constant term at early edge of image [Hz] = Value: Level 1.1 (ScanSAR mode: = 0 (fixed value)) = Value: Level 1.5/3.1 Geo-reference = Blanks: Level 1.5/3.1 Geo-coded	In level 1.5/3.1 Geo-coded bbbbbbbbbbbbbbbb
101	1431 - 1446	F16.7	Along track Doppler frequency (center) linear coefficient terms at early edge of image [Hz/pixel] = Value: Level 1.1 (ScanSAR mode: 0 (fixed value)) = Value: Level 1.5/3.1 Geo-reference = Blanks: Level 1.5/3.1 Geo-coded	In level 1.5/3.1 Geo-coded bbbbbbbbbbbbbbbb
102	1447 - 1462	F16.7	Along track Doppler frequency (center) quadratic coefficient terms at early edge of image [Hz/pixel/pixel] = Value: Level 1.1 (ScanSAR mode: 0 (fixed value)) = Value: Level 1.5/3.1 Geo-reference = Blanks: Level 1.5/3.1 Geo-coded	In level 1.5/3.1 Geo-coded bbbbbbbbbbbbbbbb
103	1463 - 1478	A16	Spare = Blanks (fixed value)	bbbbbbbbbbbbbbbb
104	1479 - 1494	F16.7	Cross track Doppler frequency (center) constant term at early edge of image [Hz] = Value: Level 1.1 (ScanSAR mode: 0 (fixed value)) = Value: Level 1.5/3.1 Geo-reference = Blanks: Level 1.5/3.1 Geo-coded	In level 1.5/3.1 Geo-coded bbbbbbbbbbbbbbbb

A

A

**Table 3.3-5 Data set summary records (9/16)**

Field No.	Byte No.	Type	Description	Remarks
105	1495 - 1510	F16.7	Cross track Doppler frequency (center) linear coefficient terms at early edge of image [Hz/pixel] = Value: Level 1.1 (ScanSAR mode: 0 (fixed value)) = Value: Level 1.5/3.1 Geo-reference = Blanks: Level 1.5/3.1 Geo-coded	In level 1.5/3.1 Geo-coded bbbbbbbbbbbbbb
106	1511 - 1526	F16.7	Cross track Doppler frequency (center) quadratic coefficient terms at early edge of image [Hz/pixel/pixel] = Value: Level 1.1 (ScanSAR mode: 0 (fixed value)) = Value: Level 1.5/3.1 Geo-reference = Blanks: Level 1.5/3.1 Geo-coded	In level 1.5/3.1 Geo-coded bbbbbbbbbbbbbb
107	1527 - 1534	A8	Time direction indicator along pixel direction = Blanks (fixed value)	bbbbbb
108	1535 - 1542	A8	Time direction indicator along line direction (Nominal value) Ascending = 'ASCENDbb' Descending = 'DESCENDb'	ASCENDbb
109	1543 - 1558	F16.7	Along track Doppler frequency rate constant terms at early edge of the image [Hz/sec] = Value: Level 1.1 (ScanSAR mode: 0 (fixed value)) = Value: Level 1.5/3.1 Geo-reference = Blanks: Level 1.5/3.1 Geo-coded	In level 1.5/3.1 Geo-coded bbbbbbbbbbbbbb
110	1559 - 1574	F16.7	Along track Doppler frequency rate linear coefficient at early edge of the image [Hz/sec/pixel] = Value: Level 1.1 (ScanSAR mode: 0 (fixed value)) = Value: Level 1.5/3.1 Geo-reference = Blanks: Level 1.5/3.1 Geo-coded	In level 1.5/3.1 Geo-coded bbbbbbbbbbbbbb
111	1575 - 1590	F16.7	Along track Doppler frequency rate quadratic coefficient at early edge of the image [Hz/sec/pixel/pixel] = Value: Level 1.1 (ScanSAR mode: 0 (fixed value)) = Value: Level 1.5/3.1 Geo-reference = Blanks: Level 1.5/3.1 Geo-coded	In level 1.5/3.1 Geo-coded bbbbbbbbbbbbbb
112	1591 - 1606	A16	Spare = Blanks (fixed value)	bbbbbbbbbbbbbb

A

A

**Table 3.3-5 Data set summary records (10/16)**

Field No.	Byte No.	Type	Description	Remarks
113	1607 - 1622	F16.7	Cross track Doppler frequency rate constant terms at early edge of the image [Hz/sec] = Value: Level 1.1 (ScanSAR mode: 0 (fixed value)) = Value: Level 1.5/3.1 Geo-reference = Blanks: Level 1.5/3.1 Geo-coded	In level 1.5/3.1 Geo-coded bbbbbbbbbbbbbb
114	1623 - 1638	F16.7	Cross track Doppler frequency rate linear coefficient at early edge of the image [Hz/sec/pixel] = Value: Level 1.1 (ScanSAR mode: 0 (fixed value)) = Value: Level 1.5/3.1 Geo-reference = Blanks: Level 1.5/3.1 Geo-coded	In level 1.5/3.1 Geo-coded bbbbbbbbbbbbbb
115	1639 - 654	F16.7	Cross track Doppler frequency rate quadratic coefficient at early edge of the image [Hz/sec/pixel/pixel] = Value: Level 1.1 (ScanSAR mode: 0 (fixed value)) = Value: Level 1.5/3.1 Geo-reference = Blanks: Level 1.5/3.1 Geo-coded	In level 1.5/3.1 Geo-coded bbbbbbbbbbbbbb
116	1655 - 1670	A16	Spare = Blanks (fixed value)	bbbbbbbbbbbbbb
117	1671 - 1678	A8	Line content indicator = 'RANGEBbb': Level 1.1 = 'OTHERbbb': Level 1.5/3.1	In the case of level 1.1 RANGEBbb
118	1679 - 1682	A4	Clutter lock applied flag = 'YESb', 'NObb'	
119	1683 - 1686	A4	Auto-focusing applied flag = 'YESb', 'NObb'	
120	1687 - 1702	F16.7	Line spacing [m] Level 1.1 : Calculated azimuth spacing Level 1.5/3.1 : 0.625 (Spotlight) 2.5 (Ultra-fine) 3.125 (Ultra-fine, High-sensitive (Full (Quad.) pol.)) 6.25 (Fine, Fine (Full (Quad.) pol.)) 25 (ScanSAR nominal [14MHz], ScanSAR nominal [28MHz], ScanSAR wide)	In level 1.5/3.1, the pixel spacing is not defined as the value on a reference ellipsoid but as the value on a map coordinates.

A

A

**Table 3.3-5 Data set summary records (11/16)**

Field No.	Byte No.	Type	Description	Remarks
121	1703 - 1718	F16.7	Pixel spacing [m] Level 1.1: Calculated range spacing Level 1.5/3.1: 0.625 (Spotlight) 2.5 (Ultra-fine) 3.125 (Ultra-fine, High-sensitive (Full (Quad.) pol.)) 6.25 (Fine, Fine (Full (Quad.) pol.)) 25 (ScanSAR nominal [14MHz], ScanSAR nominal [28MHz], ScanSAR wide)	In level 1.5/3.1, the pixel spacing is not defined as the value on a reference ellipsoid but as the value on a map coordinates.
122	1719 - 1734	A16	Processor range compression designator = 'EXTRACTEDbCHIRPb'	
123	1735 - 1750	F16.7	Doppler center frequency approximately coefficient constant term (a)	fd = a + b • R
124	1751 - 1766	F16.7	Doppler center frequency approximately linear coefficient term (b)	fd: Doppler center frequency [Hz] R: Slant range [km]
SENSOR SPECIFIC LOCAL USE SEGMENT				

**Table 3.3-5 Data set summary records (12/16)**

Field No.	Byte No.	Type	Description	Remarks
125	1767 - 1770	I4	Calibration mode data location flag No calibration data = 'bbb0' The side of observation start = 'bbb1' The side of observation end = 'bbb2' The side of observation start/end = 'bbb3'	bbb0 In the case of no calibration data <u>Observation mode</u> Start line number of calibration mode at upper image = 0 End line number of calibration mode at upper image = 0 Start line number of calibration mode at bottom image = 0 End line number of calibration mode at bottom image = 0 In the case of including calibration data at the edge of upper image l                    m                    n <u>Calibration mode</u> <u>Observation mode</u> Start line number of calibration mode at upper image = 1 End line number of calibration mode at upper image = m Start line number of calibration mode at bottom image = 0 End line number of calibration mode at bottom image = 0

Table 3.3-5 Data set summary records (13/16)

Field No.	Byte No.	Type	Description	Remarks
125 (Continuous)				<p>In the case of including calibration data at the edge of bottom image</p> <p style="text-align: center;">1                      m                      n</p> <p><span style="border: 1px solid black; padding: 0 5px;">Observation mode</span>   <span style="border: 1px solid black; padding: 0 5px;">Calibration mode</span></p> <p>Start line number of calibration mode at upper image = 0 End line number of calibration mode at upper image = 0 Start line number of calibration mode at bottom image = m End line number of calibration mode at bottom image = n</p> <p>In the case of including calibration data at the edges of upper and bottom image</p> <p style="text-align: center;">1                      m                      n</p> <p><span style="border: 1px solid black; padding: 0 5px;">Calibration mode</span></p> <p>Start line number of calibration mode at upper image = 1 End line number of calibration mode at upper image = n Start line number of calibration mode at bottom image = 1 End line number of calibration mode at bottom image = n</p> <p style="text-align: center;">or</p> <p style="text-align: center;">1                      m1                      m2                      n</p> <p><span style="border: 1px solid black; padding: 0 5px;">Cal. mode</span>   <span style="border: 1px solid black; padding: 0 5px;">Obs. mode</span>   <span style="border: 1px solid black; padding: 0 5px;">Cal. mode</span></p> <p>Start line number of calibration at the side of start = 1 End line number of calibration at the side of start = m1 Start line number of calibration at the side of end = m2 End line number of calibration at the side of end = n</p>

**Table 3.3-5 Data set summary records (14/16)**

Field No.	Byte No.	Type	Description	Remarks
126	1771 - 1778	I8	Start line number of calibration at the side of start In case of calibration location flag is '0', always = 'bbbbbbb0'	bbbbbbb0
127	1779 - 1786	I8	End line number of calibration at the side of start In case of calibration location flag is '0', always = 'bbbbbbb0'	bbbbbbb0
128	1787 - 1794	I8	Start line number of calibration at the side of end In case of calibration location flag is '0', always = 'bbbbbbb0'	bbbbbbb0
129	1795 - 1802	I8	End line number of calibration at the side of end In case of calibration location flag is '0', always = 'bbbbbbb0'	bbbbbbb0
130	1803 - 1806	I4	PRF switching indicator A fixed PRF 1 scene = 'bbb0' Variable PRFs = 'bbb1' ScanSAR mode = 'bbb1'	bbb0
131	1807 - 1814	I8	Line number of PRF switching A fixed PRF = 'bbbbbbb1' ScanSAR mode = 'bbbbbbb0'	bbbbbbb1
132	1815 - 1830	F16.7	The direction of a beam center in a scene center [deg] = Value: Level 1.1 = Value: Level 1.5/3.1 Geo-reference = Blanks: Level 1.5/3.1 Geo-coded	In level 1.5/3.1 Geo-coded bbbbbbbbbbbbbbbb
133	1831 - 1834	I4	Yaw steering mode flag No yaw steering mode = 'bbb1' Yaw steering mode = 'bbb0'	bbb0
134	1835 - 1838	I4	Parameter table number of automatically setting = 'bbbb'	bbbb
135	1839 - 1854	F16.7	Nominal off nadir angle	bbbbbb24.2000000 Nominal value
136	1855 - 1858	I4	Antenna beam number	bb10
137	1859 - 1886	A28	Spare = Blanks	bbbbbbbbbbbbbbbbbbbbbbbbbbbb
			PROCESSING SPECIFIC LOCAL USE SEGMENT	

**Table 3.3-5 Data set summary records (15/16)**

Field No.	Byte No.	Type	Description	Remarks
138	1887 - 1906	E20.13	Incidence angle constant term (a0) = Value: Level 1.1 = Value: Level 1.5/3.1 Geo-reference = Blanks: Level 1.5/3.1 Geo-coded	Level 1.5/3.1 Geo-coded Blanks (b*120)  $\theta = a_0 + a_1 * R + a_2 * R^2 + a_3 * R^3 + a_4 * R^4 + a_5 * R^5$ $\theta$ : Incidence angle [rad] R: Slant range [km]
139	1907 - 1926	E20.13	Incidence angle linear coefficient term (a1) = Value: Level 1.1 = Value: Level 1.5/3.1 Geo-reference = Blanks: Level 1.5/3.1 Geo-coded	
140	1927 - 1946	E20.13	Incidence angle quadratic coefficient term (a2) = Value: Level 1.1 = Value: Level 1.5/3.1 Geo-reference = Blanks: Level 1.5/3.1 Geo-coded	
141	1947 - 1966	E20.13	Incidence angle cubic coefficient term (a3) = Value: Level 1.1 = Value: Level 1.5/3.1 Geo-reference = Blanks: Level 1.5/3.1 Geo-coded	
142	1967 - 1986	E20.13	Incidence angle fourth coefficient term (a4) = Value: Level 1.1 = Value: Level 1.5/3.1 Geo-reference = Blanks: Level 1.5/3.1 Geo-coded	
143	1987 - 2006	E20.13	Incidence angle fifth coefficient term (a5) = Value: Level 1.1 = Value: Level 1.5/3.1 Geo-reference = Blanks: Level 1.5/3.1 Geo-coded	
			IMAGE ANNOTATION SEGMENT	
139	2007 - 2014	18	Number of annotation points (up to 64) = 'bbbbbb0'	bbbbbb0



**Table 3.3-5 Data set summary records (16/16)**

Field No.	Byte No.	Type	Description	Remarks
140	2015 - 2022	A8	Spare = Blanks	bbbbbbbbb
141	2023 - 2030	I8	Line number of 1 <sup>st</sup> annotation start = Blanks	bbbbbbbbb
142	2031 - 2038	I8	Pixel number of 1 <sup>st</sup> annotation start = Blanks	bbbbbbbbb
143	2039 - 2054	A16	1 <sup>st</sup> annotation text = Blanks	bbbbbbbbbbbbbbbb
144	2055 - 2062	I8	Line number of 2 <sup>nd</sup> annotation start = Blanks	bbbbbbbbb
145	2063 - 2070	I8	Pixel number of 2 <sup>nd</sup> annotation start = Blanks	bbbbbbbbb
146	2071 - 2086	A16	2 <sup>nd</sup> annotation text = Blanks	bbbbbbbbbbbbbbbb
.	.	.	Line number of N <sup>th</sup> annotation start = Blanks	Repeat up to 64 <sup>th</sup>
.	.	.	Pixel number of N <sup>th</sup> annotation start = Blanks	Repeat up to 64 <sup>th</sup>
.	.	.	N <sup>th</sup> annotation text = Blanks	Repeat up to 64 <sup>th</sup>
147	4039 - 4046	I8	Line number of 64 <sup>th</sup> annotation start = Blanks	bbbbbbbbb
148	4047 - 4054	I8	Pixel number of 64 <sup>th</sup> annotation start = Blanks	bbbbbbbbb
149	4055 - 4070	A16	64 <sup>th</sup> annotation text = Blanks	bbbbbbbbbbbbbbbb
150	4071 - 4096	A26	System reserve = Blanks	bbbbbbbbbbbbbbbbbbbbbbbb

**Table 3.3-6 Map projection data records (1/5)**

Field No.	Byte No.	Type	Description	Remarks
1	1 - 4	B4	Record number = 3) <sub>10</sub>	Only level 1.5/3.1 has this record.
2	5 - 5	B1	1 <sup>st</sup> record sub-type code = 18) <sub>10</sub>	
3	6 - 6	B1	Record type code = 20) <sub>10</sub>	
4	7 - 7	B1	2 <sup>nd</sup> record sub-type code = 18) <sub>10</sub>	
5	8 - 8	B1	3 <sup>rd</sup> record sub-type code = 20) <sub>10</sub>	
6	9 - 12	B4	Map projection data record length = 1620) <sub>10</sub>	
7	13 - 28	A16	Blanks	
<b>MAP PROJECTION GENERAL INFORMATION</b>				
8	29 - 60	A32	Map projection Geo-coded = 'GEOCODEDbbbbbbbbbbbbbbbbbb' Geo-reference = 'GEOREFERENCEbbbbbbbbbbbbbbbbbb'	
9	61 - 76	I16	Number of pixel per line	
10	77 - 92	I16	Number of lines	
11	93 - 108	F16.7	Inter-line distance in output scene [m] (Nominal value) 0.625 (Spotlight) 2.5 (Ultra-fine) 3.125 (Ultra-fine, High-sensitive (Full (Quad.) pol.)) 6.25 (Fine, Fine (Full (Quad.) pol.)) 25 (ScanSAR nominal [14MHz], ScanSAR nominal [28MHz], ScanSAR wide)	The inter-line/pixel distances is not defined as the value on a reference ellipsoid but as the value on a map coordinates.
12	109 - 124	F16.7	Inter-pixel distance in output scene [m] (Nominal value) 0.625 (Spotlight) 2.5 (Ultra-fine) 3.125 (Ultra-fine, High-sensitive (Full (Quad.) pol.)) 6.25 (Fine, Fine (Full (Quad.) pol.)) 25 (ScanSAR nominal [14MHz], ScanSAR nominal [28MHz], ScanSAR wide)	
13	125 - 140	F16.7	The angle between projection axis from true north at processed scene center [deg]	
14	141 - 156	F16.7	Actual platform orbital Inclination = 0.0000000	
15	157 - 172	F16.7	Actual ascending node = 0.0000000	
16	173 - 188	F16.7	Distance of platform at input scene center from the geocentric [m]	
17	189 - 204	F16.7	Geodetic altitude of the platform relative to the ellipsoid [m]	

**Table 3.3-6 Map projection data records (2/5)**

Field No.	Byte No.	Type	Description	Remarks
18	205 – 220	F16.7	Actual ground speed at nadir at input scene center time [m/sec]	
19	221 – 236	F16.7	Platform headings [deg]	
			<b>PROJECTION ELLIPSOID PARAMETERS</b>	
20	237 - 268	A32	Name of reference ellipsoid = 'GRS80bbbbbbbbbbbbbbbbbbbb'	
21	269 - 284	F16.7	Semi-major axis of referenced ellipsoid [m] = 6378137.0000000	
22	285 - 300	F16.7	Semi-minor axis of referenced ellipsoid [m] = 6356752.3141000	
23	301 – 316	F16.7	Datum shift parameter (dx) [m] = 0.0000000	
24	317 - 332	F16.7	Datum shift parameter (dy) [m] = 0.0000000	
25	333 - 348	F16.7	Datum shift parameter (dz) [m] = 0.0000000	
26	349 - 364	F16.7	Datum shift (1 <sup>st</sup> rotation angle) = 0.0000000	
27	365 – 380	F16.7	Datum shift (2 <sup>nd</sup> rotation angle) = 0.0000000	
28	381 - 396	F16.7	Datum shift (3 <sup>rd</sup> rotation angle) = 0.0000000	
29	397 - 412	F16.7	Scale factor of referenced ellipsoid = 0.0000000	
			<b>MAP PROJECTION DESIGNATOR</b>	
30	413 - 444	A32	Alphanumeric description of map projection = 'UTM-PROJECTIONbbbbbbbbbbbbbbbb': UTM-projection = 'UPS-PROJECTIONbbbbbbbbbbbbbbbb': PS-projection = 'MER-PROJECTIONbbbbbbbbbbbbbbbb': Mercator-projection = 'LCC-PROJECTIONbbbbbbbbbbbbbbbb': LCC-projection	
			<b>UTM-PROJECTION (1<sup>st</sup> default)</b>	
31	445 - 476	A32	Type of UTM = 'UNIVERSALbTRANSVERSEbMERCATORbbb'	Blanks except UTM
32	477 - 480	A4	UTM zone number	
33	481 - 496	F16.5	Map origin (false easting) [m] = 500000.00000	
34	497 - 512	F16.5	Map origin (false northing)[m] = 0.00000: Northern Hemisphere = 10000000.00000: Southern Hemisphere	
35	513 - 528	F16.7	Center of projection longitude [deg]	
36	529 - 544	F16.7	Center of projection latitude [deg]	
37	545 - 560	A16	Blanks	

**Table 3.3-6 Map projection data records (3/5)**

Field No.	Byte No.	Type	Description	Remarks
38	561 – 576	A16	Blanks	Blanks except UTM
39	577 - 592	F16.7	Scale factor = 0.9996000	
			UPS-PROJECTION (2 <sup>nd</sup> default)	
40	593 - 624	A32	Type of UPS = 'UNIVERSALbPOLARbSTEREOGRAPHICbbb'	Blanks except UPS
41	625 – 640	F16.7	Center of projection longitude [deg]	
42	641 - 656	F16.7	Center of projection latitude [deg]	
43	657 - 672	F16.7	Scale factor = 1.0000000	
			NATIONAL SYSTEM PROJECTION (any other)	
44	673 - 704	A32	Projection descriptor = 'MERCATORbbbbbbbbbbbbbbbbbb': MER-PROJECTION = 'LAMBERT-CONFORMALbCONICbbbbbb': LCC-PROJECTION	Blanks except MER and LCC
45	705 - 720	F16.5	Map origin (false easting) [m] = Blanks	
46	721 – 736	F16.5	Map origin (false northing) [m] = Blanks	
47	737 – 752	F16.7	Center of projection longitude [deg] (In either case MER/LCC, set up center map origin lat/lon)	
48	753 – 768	F16.7	Center of projection latitude [deg] (In either case MER/LCC, set up center map origin lat/lon)	
49	769 - 784	F16.7	Standard parallel [deg] (Standard parallel $\phi_1$ ) MER: 0.0 fixed, LCC: latitude of scene center	
50	785 – 800	F16.7	Standard parallel [deg] (Standard parallel $\phi_2$ ) MER: 0.0 fixed, LCC: latitude of scene center	
51	801 - 816	F16.7	Standard parallel [deg] = Blanks	
52	817 – 832	F16.7	Standard parallel [deg] = Blanks	
53	833 - 848	F16.7	Central meridian [deg] = Blanks	
54	849 – 864	F16.7	Central meridian [deg] = Blanks	
55	865 - 880	F16.7	Central meridian [deg] = Blanks	
56	881 - 944	A64	Blanks	
			COORDINATES OF FOUR CORNER POINTS	
57	945 – 960	F16.7	Top left corner northing [km]	Set the X coordinate value (at the center of pixel)
58	961 – 976	F16.7	Top left corner easting [km]	Set the Y coordinate value (same as above)
59	977 – 992	F16.7	Top right corner northing [km]	Set the X coordinate value (same as above)
60	993 - 1008	F16.7	Top right corner easting [km]	Set the Y coordinate value

D

				(same as above)
--	--	--	--	-----------------

**Table 3.3-6 Map projection data records (4/5)**

Field No.	Byte No.	Type	Description	Remarks
61	1009 – 1024	F16.7	Bottom right corner northing [km]	Set the X coordinate value (same as above)
62	1025 – 1040	F16.7	Bottom right corner easting [km]	Set the Y coordinate value (same as above)
63	1041 – 1056	F16.7	Bottom left corner northing [km]	Set the X coordinate value (same as above)
64	1057 - 1072	F16.7	Bottom left corner easting [km]	Set the Y coordinate value (same as above)
65	1073 – 1088	F16.7	Top left corner latitude [deg]	Set latitude at the center of pixel at the top left corner
66	1089 – 1104	F16.7	Top left corner longitude [deg]	Set longitude at the center of pixel at the top left corner
67	1105 – 1120	F16.7	Top right corner latitude [deg]	Set latitude at the center of pixel at the top right corner
68	1121 – 1136	F16.7	Top right corner longitude [deg]	Set longitude at the center of pixel at the top right corner
69	1137 – 1152	F16.7	Bottom right corner latitude [deg]	Set latitude at the center of pixel at the bottom right corner
70	1153 – 1168	F16.7	Bottom right corner longitude [deg]	Set longitude at the center of pixel at the bottom right corner
71	1169 - 1184	F16.7	Bottom left corner latitude [deg]	Set latitude at the center of pixel at the bottom left corner
72	1185 - 1200	F16.7	Bottom left corner longitude [deg]	Set longitude at the center of pixel at the bottom left corner
73	1201 - 1216	A16	Top left corner terrain height relative to ellipsoid [m] = Blanks	
74	1217 – 1232	A16	Top right corner terrain height relative to ellipsoid [m] = Blanks	
75	1233 – 1248	A16	Bottom right corner terrain height relative to ellipsoid [m] = Blanks	
76	1249 – 1264	A16	Bottom left corner terrain height relative to ellipsoid [m] = Blanks	

D

Table 3.3-6 Map projection data records (5/5)

77	1265 - 1424	8E20.10	<p>Eight coefficients to convert a line(L) and pixel(P) position to the map projection frame of reference, say (E, N) where:  <math>E = A11 + A12*L + A13*P + A14*L*P</math>  <math>N = A21 + A22*L + A23*P + A24*L*P</math>                      The order of storing: A11, A12, A13, ..., A24                      The coefficients of 1025-2024 bytes in facility related data record 5 should be used if high position accuracy is needed.</p>	<p>For the expressions, the position defined as (P, L) = (1, 1). corresponds to the central point of the pixel at the upper left corner and (E, N) show a longitude [deg] and a latitude [deg.].</p>
78	1425 - 1584	8E20.10	<p>Eight coefficients to convert from the map projection (E, N) to line(L) and pixel(P) position in the image, say (L, P) where:  <math>L = B11 + B12*E + B13*N + B14*E*N</math>  <math>P = B21 + B22*E + B23*N + B24*E*N</math>                      The order of storing: B11, B12, B13, ..., B24                      The coefficients of 2065-3064 bytes in facility related data record 5 should be used if high position accuracy is needed.</p>	
79	1585 - 1620	A36	Blanks	

C  
C

**Table 3.3-7 Platform position data records (1/3)**

Field No.	Byte No.	Type	Description	Remarks
1	1 - 4	B4	Record number Level 1.1 = 3) <sub>10</sub> Level 1.5/3.1 = 4) <sub>10</sub>	
2	5 - 5	B1	1 <sup>st</sup> record sub-type code = 18) <sub>10</sub>	12h
3	6 - 6	B1	Record type code = 30) <sub>10</sub>	1Eh
4	7 - 7	B1	2 <sup>nd</sup> record sub-type code = 18) <sub>10</sub>	12h
5	8 - 8	B1	3 <sup>rd</sup> record sun-type code = 20) <sub>10</sub>	14h
6	9 - 12	B4	Platform position data record length = 4680) <sub>10</sub>	00001248h
7	13 - 44	A32	Orbital elements designator Orbit information (preliminary) = '0bbbbbbbbbbbbbbbbbbbbbbbbbbbbbb' Orbit information (decision) = '1bbbbbbbbbbbbbbbbbbbbbbbbbbbbbb' High precision orbit information = '2bbbbbbbbbbbbbbbbbbbbbbbbbbbbbb'	2bbbbbbbbbbbbbbbbbbbbbbbbbb bbbbbb
8	45 - 60	F16.7	1 <sup>st</sup> orbital element Position vector in the earth fixed coordinate system of the scene center (x) [m]	
9	61 - 76	F16.7	2 <sup>nd</sup> orbital element Position vector in the earth fixed coordinate system of the scene center (y) [m]	
10	77 - 92	F16.7	3 <sup>rd</sup> orbital element Position vector in the earth fixed coordinate system of the scene center (z) [m]	
11	93 - 108	F16.7	4 <sup>th</sup> orbital element Velocity vector in the earth fixed coordinate system of the scene center (x') [m/sec]	
12	109 - 124	F16.7	5 <sup>th</sup> orbital element Velocity vector in the earth fixed coordinate system of the scene center (y') [m/sec]	
13	125 - 140	F16.7	6 <sup>th</sup> orbital element Velocity vector in the earth fixed coordinate system of the scene center (z') [m/sec]	
14	141 - 144	I4	Number of data points Orbit information (preliminary) = 'bb28' Orbit information (decision) = 'bb28' High precision orbit information = 'bb28'	bb28
15	145 - 148	I4	YYYY : Year of 1 <sup>st</sup> point	2015
16	149 - 152	I4	bbMM : Month of 1 <sup>st</sup> point	bb02

C  
C  
C

**Table 3.3-7 Platform position data records (2/3)**

Field No.	Byte No.	Type	Description	Remarks
17	153 - 156	I4	bbDD : Day of 1 <sup>st</sup> point	bb02
18	157 - 160	I4	Day in the year of 1 <sup>st</sup> point (Ex: 2 <sup>nd</sup> February = 33 <sup>th</sup> )	bb33
19	161 - 182	E22.15	Seconds of day of 1 <sup>st</sup> point (Ex: 0:51:30.23 = 3090.23)	b0.3090230000000000E+04
20	183 - 204	E22.15	Time interval between data points [sec] = 60	b0.6000000000000000E+02
21	205 - 268	A64	Reference co-ordinate system (ECI, ECR) = 'ECRbb'	ECRbb bb
22	269 - 290	E22.15	Greenwich mean hour angle [deg] = Blanks (fixed value)	bbbbbbbbbbbbbbbbbbbb
23	291 - 306	F16.7	Along track position error [m] = Nominal value	(Along track position error)
24	307 - 322	F16.7	Across track position error [m] = Nominal value	(Across track position error)
25	323 - 338	F16.7	Radial position error [m] = Nominal value	(Radial position error)
26	339 - 354	F16.7	Along track velocity error [m/sec] = Nominal value	(Along track velocity error)
27	355 - 370	F16.7	Across track velocity error [m/sec] = Nominal value	(Across track velocity error)
28	371 - 386	F16.7	Radial velocity error [m/sec] = Nominal value	(Radial velocity error)
FIRST POSITIONAL DATA POINT				
29	387 - 408	E22.15	1 <sup>st</sup> data point position vector (x) [m]	(1 <sup>st</sup> data point position vector)
30	409 - 430	E22.15	1 <sup>st</sup> data point position vector (y) [m]	(1 <sup>st</sup> data point position vector)
31	431 - 452	E22.15	1 <sup>st</sup> data point position vector (z) [m]	(1 <sup>st</sup> data point position vector)
32	453 - 474	E22.15	1 <sup>st</sup> data point position vector (x') [m/sec]	(1 <sup>st</sup> data point position vector)
33	475 - 496	E22.15	1 <sup>st</sup> data point position vector (y') [m/sec]	(1 <sup>st</sup> data point position vector)
34	497 - 518	E22.15	1 <sup>st</sup> data point position vector (z') [m/sec]	(1 <sup>st</sup> data point position vector)
	519 - 4082	27*6* E22.15	Repeat 2 <sup>nd</sup> - 28 <sup>th</sup> data point same as 387-518 bytes	



**Table 3.3-7 Platform position data records (3/3)**

Field No.	Byte No.	Type	Description	Remarks
35	4083 - 4100	A18	Blanks	bbbbbbbbbbbbbbbb
36	4101 - 4101	I1	Occurrence flag of a leap second No leap second = '0' Occurrence of a leap second = '1'	0 This flag is "1" if a scene includes line times before and after the TAI-UTC change time.
37	4102 - 4680	A579	Blanks	Blanks (b*579)

**Table 3.3-8 Attitude data records (1/2)**

Field No.	Byte No.	Type	Description	Remarks
1	1 - 4	B4	Record number Level 1.1 = 4) <sub>10</sub> Level 1.5/3.1 = 5) <sub>10</sub>	
2	5 - 5	B1	1 <sup>st</sup> record sub-type code = 18) <sub>10</sub>	12h
3	6 - 6	B1	Record type code = 40) <sub>10</sub>	28h
4	7 - 7	B1	2 <sup>nd</sup> record sub-type code = 18) <sub>10</sub>	12h
5	8 - 8	B1	3 <sup>rd</sup> record sub-type code = 20) <sub>10</sub>	14h
6	9 - 12	B4	Attitude data records length = 16384) <sub>10</sub>	00004000h
7	13 - 16	I4	Number of points = 'bb22': Except ScanSAR mode = 'bb62': ScanSAR mode	bb22
8	17 - 20	I4	Day of the year	bbb1
9	21 - 28	I8	Milli-second of the day = 'bbbbbb0'~'86399999'	bbb28800
10	29 - 32	I4	Pitch data quality flag Good (within limit check) = 'bbb0' NG (out of limit check) = 'bbb1'	bbb0
11	33 - 36	I4	Roll data quality flag Good (within limit check) = 'bbb0' NG (out of limit check) = 'bbb1'	bbb0
12	37 - 40	I4	Yaw data quality flag Good (within limit check) = 'bbb0' NG (out of limit check) = 'bbb1'	bbb0
13	41 - 54	E14.6	Pitch [deg]	(Pitch)
14	55 - 68	E14.6	Roll [deg]	(Roll)
15	69 - 82	E14.6	Yaw [deg]	(Yaw)

**Table 3.3-8 Attitude data records (2/2)**

Field No.	Byte No.	Type	Description	Remarks
16	83 - 86	I4	Pitch rate quality flag Good (within limit check) = 'bbb0' NG (out of limit check) = 'bbb1'	bbb0
17	87 - 90	I4	Roll rate quality flag Good (within limit check) = 'bbb0' NG (out of limit check) = 'bbb1'	bbb0
18	91 - 94	I4	Yaw rate quality flag Good (within limit check) = 'bbb0' NG (out of limit check) = 'bbb1'	bbb0
19	95 - 108	E14.6	Pitch rate	(Pitch rate)
20	109 - 122	E14.6	Roll rate	(Roll rate)
21	123 - 136	E14.6	Yaw rate	(Yaw rate)
	137 - 136+120*(n-1)	120*(n-1)	Repeat bytes 17-136 for the number of points (n ) in section 7	
22	137+120*(n-1) - 16384	A(16384- (136+120 *(n-1)))	Blanks	The value of Level 1.0 is copied

**Table 3.3-9 Radiometric data records (1/2)**

Field No.	Byte No.	Type	Description	Remarks
1	1 - 4	B4	Record number Level 1.1 = 5) <sub>10</sub> Level 1.5/3.1 = 6) <sub>10</sub>	
2	5 - 5	B1	1 <sup>st</sup> record sub-type code = 18) <sub>10</sub>	
3	6 - 6	B1	Record type code = 50) <sub>10</sub>	
4	7 - 7	B1	2 <sup>nd</sup> sub-type code = 18) <sub>10</sub>	
5	8 - 8	B1	3 <sup>rd</sup> sub-type code = 20) <sub>10</sub>	
6	9 - 12	B4	Radiometric data record length = 9860) <sub>10</sub>	
7	13 - 16	I4	Radiometric data records sequence number = 'bbb1'	
8	17 - 20	I4	Number of radiometric fields = 'bbb1'	
<b>RADIOMETRIC DATA SET</b>				
9	21 - 36	F16.7	Calibration factor (CF) Level 1.1: $\sigma^0 = 10 * \log_{10} \langle I^2 + Q^2 \rangle + CF - 32.0$ Level 1.5/3.1: $\sigma^0 = 10 * \log_{10} \langle DN^2 \rangle + CF$ This means that the sigma-naught of a pixel can be obtained by the ensemble averaging ( $\langle \rangle$ ), i.e., the spatial averaging of pixel values around the target. Here, I, Q, and DN in $\langle \rangle$ of the above formulas are the pixel values in levels 1.1, and 1.5/3.1, respectively.	except ScanSAR level 1.1 products by the full aperture method.
10	37 - 52	F16.7	Transmission distortion matrix for High-sensitive/Fine modes (Full (Quad.) pol.) level 1.1 (DT) (*) Real part of DT(1, 1)	
11	53 - 68	F16.7	Imaginary part of DT(1, 1)	
12	69 - 84	F16.7	Real part of DT(1, 2)	
13	85 - 100	F16.7	Imaginary part of DT(1, 2)	
14	101 - 116	F16.7	Real part of DT(2, 1)	
15	117 - 132	F16.7	Imaginary part of DT(2, 1)	
16	133 - 148	F16.7	Real part of DT(2, 2)	
17	149 - 164	F16.7	Imaginary part of DT(2, 2)	
18	165 - 180	F16.7	Reception distortion matrix for High-sensitive/Fine modes (Full (Quad.) pol.) level 1.1 (DR) (*) Real part of DR(1, 1)	
19	181 - 196	F16.7	Imaginary part of DR(1, 1)	

F

**Table 3.3-9 Radiometric data records (2/2)**

Field No.	Byte No.	Type	Description	Remarks
20	197 - 212	F16.7	Real part of DR(1, 2)	
21	213 - 228	F16.7	Imaginary part of DR(1, 2)	
22	229 - 244	F16.7	Real part of DR(2, 1)	
23	245 - 260	F16.7	Imaginary part of DR(2, 1)	
24	261 - 276	F16.7	Real part of DR(2, 2)	
25	277 - 292	F16.7	Imaginary part of DR(2, 2)	
26	293 - 9860	A9568	Reserve (Blanks)	

(\*)Notes:

The measured scattering matrix can be expressed by

$$\begin{pmatrix} Z_{hh} & Z_{hv} \\ Z_{vh} & Z_{vv} \end{pmatrix} = A \frac{1}{r} \exp\left(-\frac{4\pi r}{\lambda} j\right) \begin{pmatrix} 1 & \delta_3 \\ \delta_4 & f_2 \end{pmatrix} \begin{pmatrix} S_{hh} & S_{hv} \\ S_{vh} & S_{vv} \end{pmatrix} \begin{pmatrix} 1 & \delta_1 \\ \delta_2 & f_1 \end{pmatrix} + \begin{pmatrix} N_{hh} & N_{hv} \\ N_{vh} & N_{vv} \end{pmatrix}$$

where  $Z_{ij}$  is the measurement matrix of the target,  $j$  is the transmission polarization,  $i$  is the reception polarization,  $A$  is the amplitude,  $r$  is the slant range,  $S_{ij}$  is the true scattering matrix of the target,  $f_1$  is the channel imbalance of the transmission distortion matrix,  $f_2$  is that for the reception matrix,  $\delta_1$  and  $\delta_2$  are the cross talks of transmission, and  $\delta_3$  and  $\delta_4$  are the those for the reception,  $N_{ij}$  are the noise component. Here,  $N_{ij}$  is assumed to be zero. It should be noted that polarization notation of the product is different from the above, i.e., IMG-HV-ALPSR..., means the data acquired at H transmission and V reception.

Complex transmission distortion matrix ( $1, \delta_1, \delta_2, f_1$ ) are stored from 37 to 164 bytes, and reception distortion matrix ( $1, \delta_3, \delta_4, \text{ and } f_2$ ) are stored from 165 to 292 bytes.

Calibration factor is stored from 21 to 36 bytes.

**Table 3.3-10 Data quality summary records (1/2)**

Field No.	Byte No.	Type	Description	Remarks
1	1 - 4	B4	Record number Level 1.1 = 6) <sub>10</sub> Level 1.5/3.1 = 7) <sub>10</sub>	
2	5 - 5	B1	1 <sup>st</sup> record sub-type code = 18) <sub>10</sub>	
3	6 - 6	B1	Record type code = 60) <sub>10</sub>	
4	7 - 7	B1	2 <sup>nd</sup> record sub-type code = 18) <sub>10</sub>	
5	8 - 8	B1	3 <sup>rd</sup> record sub-type code = 20) <sub>10</sub>	
6	9 - 12	B4	Data quality summary record length = 1620) <sub>10</sub>	
7	13 - 16	I4	Data quality summary record number = 'bbb1'	
8	17 - 20	A4	SAR channel ID = 'ABCb' A: Reception of polarization (H, V) B: Reception antenna (S: Single beam, F: F-system, R: R-system) C : I, Q	Describe the channel that is the radiometric standard of channels used in observation.
9	21 - 26	A6	Date of the last calibration update = 'YYMMDD' YY : lower 2 figures of the year MM : Month DD : Day	
10	27 - 30	A4	Number of channels (up to 8)	
<b>ABSOLUTE RADIOMETRIC DATA QUALITY</b>				
11	31 - 46	F16.7	ISLR (nominal value) [dB]	
12	47 - 62	F16.7	PSLR (nominal value) [dB]	
13	63 - 78	F16.7	Azimuth ambiguity rate (AAR) (Nominal value)	
14	79 - 94	F16.7	Range ambiguity rate (RAR) (Nominal value)	
15	95 - 110	F16.7	Estimate of SNR [dB]	
16	111 - 126	F16.7	BER (Actual value)	
17	127 - 142	F16.7	Slant range resolution (Nominal value) [m]	
18	143 - 158	F16.7	Azimuth resolution (Nominal value) [m]	
19	159 - 174	F16.7	Radiometric resolution (Nominal value) [dB]	
20	175 - 190	F16.7	Instantaneous dynamic range [dB]	

**Table 3.3-10 Data quality summary records (2/2)**

Field No.	Byte No.	Type	Description	Remarks
21	191 - 206	F16.7	Nominal absolute radiometric calibration magnitude uncertainty of SAR channel indicated in bytes 17-20 [dB]	
22	207 - 222	F16.7	Nominal absolute radiometric calibration phase uncertainty of SAR channel indicated in bytes 17-20 [deg]	
<b>RELATIVE RADIOMETRIC QUALITY</b>				
23	223 - 238	F16.7	Nominal relative radiometric calibration magnitude uncertainty of SAR channel indicated in bytes 17-20 [dB]	
24	239 - 254	F16.7	Nominal relative radiometric calibration phase uncertainty of SAR channel indicated in bytes 17-20 [deg]	
25	255 - (n-1)*32+254	(n-1)*2F16.7	Repetition of bytes 223 - 254 for the remaining channels (up to 8 channels)	
26	(n-1)*32+255 - 734	A(480 -(n-1)*32)	Blanks	
<b>ABSOLUTE GEOMETRIC DATA QUALITY</b>				
26	735 - 750	F16.7	Absolute location error along track (Nominal value) [m]	
27	751 - 766	F16.7	Absolute location error cross track (Nominal value) [m]	
28	767 - 782	F16.7	Geometric distortion scale in line direction (Nominal value)	
29	783 - 798	F16.7	Geometric distortion scale in pixel direction (Nominal value)	
30	799 - 814	F16.7	Geometric distortion skew	
31	815 - 830	F16.7	Scene orientation error	
<b>RELATIVE GEOMETRIC DATA QUALITY</b>				
32	831 - 846	F16.7	Along track relative misregistration error of other channels versus SAR channel (bytes 17-20) [meters]	
33	847 - 862	F16.7	Cross track relative misregistration error of other channels versus SAR channel (bytes 17-20) [meters]	
34	863 - 1102	(n-1)*2F16.7	Repetition of bytes 831 - 862 for the other channels (up to 8 channels)	
35	1103 - 1620	A518	Blanks	

**Table 3.3-11 Facility related data records 1 - 4 (1/2)**

Field No.	Byte No.	Type	Description	Remarks
1	1 - 4	B4	Record sequence number Level 1.1 Dummy data = 7) <sub>10</sub> Determined ephemeris = 8) <sub>10</sub> Time error information = 9) <sub>10</sub> Coordinate conversion information = 10) <sub>10</sub> Level 1.5/3.1 Dummy data = 8) <sub>10</sub> Determined ephemeris = 9) <sub>10</sub> Time error information = 10) <sub>10</sub> Coordinate conversion information = 11) <sub>10</sub>	
2	5 - 5	B1	1 <sup>st</sup> record sub-type code = 18) <sub>10</sub>	12h
3	6 - 6	B1	Record type code = 200) <sub>10</sub>	C8h
4	7 - 7	B1	2 <sup>nd</sup> record sub-type code = 18) <sub>10</sub>	12h

A



**Table 3.3-11 Facility related data records 1 - 4 (2/2)**

Field No.	Byte No.	Type	Description	Remarks
5	8 - 8	B1	3 <sup>rd</sup> record sub-type code = 70) <sub>10</sub> CEOS = 20) <sub>10</sub> , CCRS = 36) <sub>10</sub> , ESA = 50) <sub>10</sub> , NASA = 60) <sub>10</sub> , JPL = 61) <sub>10</sub> JAXA = 70) <sub>10</sub> , DFVLR = 80) <sub>10</sub> , RAE = 90) <sub>10</sub> , TELESPAZIO = 10) <sub>10</sub> UNSPECIFIED = 18) <sub>10</sub> , etc.	46h
6	9 - 12	B4	Record length Dummy data = 325,000 Determined ephemeris = 511,000 Time error information = 3,072 Coordinate conversion information = 728,000	
7	13 - 16	I4	Facility related data record sequence number = 'bbbb1'~'bbb4'	
8	17 - 66	A50	Blanks	Blanks(b*50)
9	67 -		Set the following files which were used for level 1.0 processing, for each record. Dummy data Determined ephemeris Time error information Coordinate conversion information	(Raw file data)

A

A

**Table 3.3-12 Facility related data records 5 (1/4)**

Field No.	Byte No.	Type	Description	Remarks
1	1 - 4	B4	Record sequence number Level 1.1 = 11) <sub>10</sub> Level 1.5/3.1 = 12) <sub>10</sub>	
2	5 - 5	B1	1 <sup>st</sup> record sub-type code = 18) <sub>10</sub>	
3	6 - 6	B1	Record type code = 200) <sub>10</sub>	
4	7 - 7	B1	2 <sup>nd</sup> record sub-type code = 18) <sub>10</sub>	
5	8 - 8	B1	3 <sup>rd</sup> record sub-type code = 70) <sub>10</sub> CEOS = 20) <sub>10</sub> , CCRS = 36) <sub>10</sub> , ESA = 50) <sub>10</sub> , NASA = 60) <sub>10</sub> , JPL = 61) <sub>10</sub> JAXA = 70) <sub>10</sub> , DFVLR = 80) <sub>10</sub> , RAE = 90) <sub>10</sub> , TELESPAZIO = 10) <sub>10</sub> UNSPECIFIED = 18) <sub>10</sub> , etc.	
6	9 - 12	B4	Record length = 5000) <sub>10</sub>	
7	13 - 16	I4	Facility related data record number = 'bbb5'	
8	17 - 416	20E20.10	Twenty coefficients to convert from the map projection (E, N) to Line(L) and pixel (P) position in the image, say (P, L) where: Level 1.5/3.1: $P = a_0 + a_1*\varphi + a_2*\lambda + a_3*\varphi*\lambda + a_4*\varphi^2 + a_5*\lambda^2 + a_6*\varphi^2*\lambda + a_7*\varphi*\lambda^2 + a_8*\varphi^3 + a_9*\lambda^3$ $L = b_0 + b_1*\varphi + b_2*\lambda + b_3*\varphi*\lambda + b_4*\varphi^2 + b_5*\lambda^2 + b_6*\varphi^2*\lambda + b_7*\varphi*\lambda^2 + b_8*\varphi^3 + b_9*\lambda^3$ Coefficients $a_0 - a_9$ and $b_0 - b_9$ (The order of storing $a_0, a_1, a_2, \dots, a_9$ and $b_0, b_1, b_2, \dots, b_9$ ) Level 1.1: Blanks The coefficients of 2065-3064 bytes in facility related data record 5 should be used if high position accuracy is needed.	For the expressions, the position defined as (P, L) = (1, 1). corresponds to the central point of the pixel at the upper left corner and (E, N) show a longitude [deg] and a latitude [deg]
9	417 - 420	I4	Calibration mode data location flag No calibration data = 'bbb0' The side of observation start = 'bbb1' The side of observation end = 'bbb2' The side of observation start/end = 'bbb3'	

C

**Table 3.3-12 Facility related data records 5 (2/4)**

Field No.	Byte No.	Type	Description	Remarks
10	421 - 428	I8	Start line number of calibration at upper image In case of no calibration data ('0'), always = 'bbbbbbb0'	
11	429 - 436	I8	End line number of calibration at upper image In case of no calibration data ('0'), always = 'bbbbbbb0'	
12	437 - 444	I8	Start line number of calibration at bottom image In case of no calibration data ('0'), always = 'bbbbbbb0'	
13	445 - 452	I8	Stop line number of calibration at bottom image In case of no calibration data ('0'), always = 'bbbbbbb0'	
14	453 - 456	I4	PRF switching flag No change in a scene = 'bbb0' (fixed value)	
15	457 - 464	I8	Start line number of PRF switching No change = 'bbbbbbb1' (fixed value)	
16	465 - 472	I8	Blanks	
17	473 - 480	I8	Number of loss lines (Level 1.0)	
18	481 - 488	I8	Number of loss lines (range for processing in Level 1.1/1.5/3.1)	
19	489 - 800	A312	Blanks	
20	801 - 1024	A224	System reserve	

**Table 3.3-12 Facility related data records 5 (3/4)**

Field No.	Byte No.	Type	Description	Remarks
21	1025 - 2024	50E20.10	<p>Coefficients of the 8th polynomial expression to convert from pixel (P) and line (L) to latitude (<math>\phi</math>) and longitude (<math>\lambda</math>), say (<math>\phi, \lambda</math>) where:</p> $\phi = a_0 * L^4 * P^4 + a_1 * L^3 * P^4 + a_2 * L^2 * P^4 + a_3 * L * P^4 + a_4 * P^4$ $+ a_5 * L^4 * P^3 + a_6 * L^3 * P^3 + a_7 * L^2 * P^3 + a_8 * L * P^3 + a_9 * P^3$ $+ a_{10} * L^4 * P^2 + a_{11} * L^3 * P^2 + a_{12} * L^2 * P^2 + a_{13} * L * P^2 + a_{14} * P^2$ $+ a_{15} * L^4 * P + a_{16} * L^3 * P + a_{17} * L^2 * P + a_{18} * L * P + a_{19} * P$ $+ a_{20} * L^4 + a_{21} * L^3 + a_{22} * L^2 + a_{23} * L + a_{24}$ $\lambda = b_0 * L^4 * P^4 + b_1 * L^3 * P^4 + b_2 * L^2 * P^4 + b_3 * L * P^4 + b_4 * P^4$ $+ b_5 * L^4 * P^3 + b_6 * L^3 * P^3 + b_7 * L^2 * P^3 + b_8 * L * P^3 + b_9 * P^3$ $+ b_{10} * L^4 * P^2 + b_{11} * L^3 * P^2 + b_{12} * L^2 * P^2 + b_{13} * L * P^2 + b_{14} * P^2$ $+ b_{15} * L^4 * P + b_{16} * L^3 * P + b_{17} * L^2 * P + b_{18} * L * P + b_{19} * P$ $+ b_{20} * L^4 + b_{21} * L^3 + b_{22} * L^2 + b_{23} * L + b_{24}$ <p>(The order of storing: <math>a_0, a_1, a_2, \dots, a_{24}</math> &amp; <math>b_0, b_1, b_2, \dots, b_{24}</math>)                      In the case of ScanSAR level 1.1, all coefficients are set 0.0</p>	<p>(P, L) referred in the upper left pixel(p) and line (l) are substituted by the following expressions as  <math>P = p - P_0, L = l - L_0</math>,                      where (p, l) is an arbitrary coordinate address on the image.                      For the expressions above, the position defined as (p, l)=(0, 0) corresponds to the central point of the pixel at the upper left corner and (<math>\phi, \lambda</math>) is measured in "degrees".</p> <p>In the case of ScanSAR level 1.1, refer to the field No. 50-55 in Table 3.3-14 "Signal data records (4/5)" about the relationship between an address and the location information (latitude/longitude) on the image.</p>
22	2025 - 2044	E20.10	Origin Pixel ( $P_0$ ) 0.0	
23	2045 - 2064	E20.10	Origin Line ( $L_0$ ) 0.0	

A  
C

**Table 3.3-12 Facility related data records 5 (4/4)**

Field No.	Byte No.	Type	Description	Remarks
24	2065 - 3064	50E20.10	<p>Coefficients of the 8th polynomial expression to convert from latitude (<math>\Phi</math>) and longitude (<math>\Lambda</math>) to pixel (<math>p</math>) and line (<math>l</math>), say (<math>p, l</math>) where:</p> $p = c_0 * \Lambda^4 * \Phi^4 + c_1 * \Lambda^3 * \Phi^4 + c_2 * \Lambda^2 * \Phi^4 + c_3 * \Lambda * \Phi^4 + c_4 * \Phi^4$ $+ c_5 * \Lambda^4 * \Phi^3 + c_6 * \Lambda^3 * \Phi^3 + c_7 * \Lambda^2 * \Phi^3 + c_8 * \Lambda * \Phi^3 + c_9 * \Phi^3$ $+ c_{10} * \Lambda^4 * \Phi^2 + c_{11} * \Lambda^3 * \Phi^2 + c_{12} * \Lambda^2 * \Phi^2 + c_{13} * \Lambda * \Phi^2 + c_{14} * \Phi^2$ $+ c_{15} * \Lambda^4 * \Phi + c_{16} * \Lambda^3 * \Phi + c_{17} * \Lambda^2 * \Phi + c_{18} * \Lambda * \Phi + c_{19} * \Phi$ $+ c_{20} * \Lambda^4 + c_{21} * \Lambda^3 + c_{22} * \Lambda^2 + c_{23} * \Lambda + c_{24}$ $l = d_0 * \Lambda^4 * \Phi^4 + d_1 * \Lambda^3 * \Phi^4 + d_2 * \Lambda^2 * \Phi^4 + d_3 * \Lambda * \Phi^4 + d_4 * \Phi^4$ $+ d_5 * \Lambda^4 * \Phi^3 + d_6 * \Lambda^3 * \Phi^3 + d_7 * \Lambda^2 * \Phi^3 + d_8 * \Lambda * \Phi^3 + d_9 * \Phi^3$ $+ d_{10} * \Lambda^4 * \Phi^2 + d_{11} * \Lambda^3 * \Phi^2 + d_{12} * \Lambda^2 * \Phi^2 + d_{13} * \Lambda * \Phi^2 + d_{14} * \Phi^2$ $+ d_{15} * \Lambda^4 * \Phi + d_{16} * \Lambda^3 * \Phi + d_{17} * \Lambda^2 * \Phi + d_{18} * \Lambda * \Phi + d_{19} * \Phi$ $+ d_{20} * \Lambda^4 + d_{21} * \Lambda^3 + d_{22} * \Lambda^2 + d_{23} * \Lambda + d_{24}$ <p>(The order of storing: <math>c_0, c_1, c_2, \dots, c_{24}</math> &amp; <math>d_0, d_1, d_2, \dots, d_{24}</math>)                      In the case of ScanSAR level 1.1, all coefficients are set 0.0</p>	<p>(<math>\Phi, \Lambda</math>) referred in the upper left latitude(<math>\phi</math>), longitude(<math>\lambda</math>) are substituted by the following expressions as  <math>F=f-F_0</math> (degrees),  <math>L=l-L_0</math> (degrees),                      where (<math>f, l</math>) is an arbitrary position on the image.                      For the expressions, the position defined as  <math>(p, l)=(0, 0)</math>                      corresponds to the central point of the pixel at the upper left corner.</p>
25	3065 - 3084	E20.10	Origin Latitude ( $\Phi_0$ ) scene center latitude	<p>In the case of ScanSAR level 1.1, refer to the field No. 50-55 in Table 3.3-14 “Signal data records (4/5)” about the relationship between an address and the location information (latitude/longitude) on the image.</p>
26	3085 - 3104	E20.10	Origin Longitude ( $\Lambda_0$ ) scene center longitude	
27	3105 - 5000	A1896	Blanks	

A

**Table 3.3-13 SAR Image file descriptor records (1/6)**

Field No.	Byte No.	Type	Description	Remarks
1	1 - 4	B4	Record number = 1) <sub>10</sub>	00000001h
2	5 - 5	B1	1 <sup>st</sup> record sub-type code = 50) <sub>10</sub>	32h
3	6 - 6	B1	Record type code = 192) <sub>10</sub>	C0h
4	7 - 7	B1	2 <sup>nd</sup> record sub-type code = 18) <sub>10</sub>	12h
5	8 - 8	B1	3 <sup>rd</sup> record sub-type code = 18) <sub>10</sub>	12h
6	9 - 12	B4	Record length = 720) <sub>10</sub>	000002D0h
7	13 - 14	A2	ASCII/EBCDIC flag = 'Ab': ASCII	Ab
8	15 - 16	A2	Blanks	bb
9	17 - 28	A12	Format control document ID = 'CEOS-SARbbbb'	CEOS-SARbbbb
10	29 - 30	A2	Format control document revision level = 'bA'	bA
11	31 - 32	A2	File design descriptor revision letter = 'bA'	bA
12	33 - 44	A12	Software release & revision number = 'NNN.NNNbbbb' 001.000, 001.001, ... 001.100, ... 002.000	001.000bbbb
13	45 - 48	I4	File number = 'bbb1'	bbb1
14	49 - 64	A16	File ID = 'MMN <b>b</b> SSST <b>FFFF</b> bbbb' MM: Mission ID (ALOS2='AL')(*) N: Mission number(='2')(*) SSS: Sensor ID (SAR='SAR')(*) T: Processing level code Level 1.0 = 'A' Level 1.1 = 'B' Level 1.5 = 'C' Level 3.1 = 'D' FFFF : File Type(*) Leader file = 'SARL' Image file = 'IMOP' Trailer file = 'SART'	AL2bSARAIMOPbbbb
15	65 - 68	A4	Record sequence and location type flag = 'FSEQ'	FSEQ
16	69 - 76	I8	Location sequence number = 'bbbbbbb1'	bbbbbbb1 (Location of record number)
17	77 - 80	I4	Field length of sequence number = 'bbb4'	bbb4 (Field length of record number)

A

**Table 3.3-13 SAR Image file descriptor records (2/6)**

Field No.	Byte No.	Type	Description	Remarks
18	81 - 84	A4	Record code and location type flag = 'FTYP'	FTYP
19	85 - 92	I8	Record code location = 'bbbbbb5'	bbbbbb5 (Record code location)
20	93 - 96	I4	Record code field length = 'bbb4'	bbb4 (Record code field length)
21	97 - 100	A4	Record length and location type flag = 'FLGT'	FLGT
22	101 - 108	I8	Record length location = 'bbbbbb9'	bbbbbb9 (Record length location)
23	109 - 112	I4	Record length field length = 'bbb4'	bbb4 (Record length field length)
24	113 - 113	A1	Reserved = Blanks	b
25	114 - 114	A1	Reserved = Blanks	b
26	115 - 115	A1	Reserved = Blanks	b
27	116 - 116	A1	Reserved = Blanks	b
28	117 - 180	A64	Reserved = Blanks	Blanks(b*64)
29	181 - 186	I6	Number of SAR data records Number of signal data records	The order of recode sequence is the order of observation time.
30	187 - 192	I6	SAR data record length	
31	193 - 216	A24	Reserved = Blanks	bbbbbbbbbbbbbbbbbbbb
SAMPLE GROUP DATA				
32	217 - 220	I4	Bit length per sample Level 1.1 = 'bb32' Level 1.5/3.1 = 'bb16'	
33	221 - 224	I4	Number of samples per data group Level 1.1 = 'bbb2' Level 1.5/3.1 = 'bbb1'	
34	225 - 228	I4	Number of bytes per data group Level 1.1 = 'bbb8' Level 1.5/3.1 = 'bbb2'	
35	229 - 232	A4	Justification and order of samples within data group = Blanks(fixed value)	bbbb

**Table 3.3-13 SAR Image file descriptor records (3/6)**

Field No.	Byte No.	Type	Description	Remarks
<b>SAR RELATED DATA IN THE RECORD</b>				
36	233 - 236	I4	Number of SAR channels = 'bbb1' (fixed value) (Only L-band)	bbb1
37	237 - 244	I8	Number of lines per data set (one channel) (Excluding border lines)	
38	245 - 248	I4	Number of left border pixels per line = 'bbb0'	bbb0
39	249 - 256	I8	Number of data group (or pixels) per line	For level 1.1 products, each data record corresponds to 1 image range line. Each range line begins at the nearest-range pixel and ends at the farthest-range pixel.
40	257 - 260	I4	Number of right border pixels per line = 'bbb0'	
41	261 - 264	I4	Number of top border lines = 'bbb0'	bbb0
42	265 - 268	I4	Number of bottom border lines = 'bbb0'	bbb0
43	269 - 272	A4	Interleaving ID = 'BSQb' (fixed value)	BSQb
<b>RECORD DATA IN THE FILE</b>				
44	273 - 274	I2	Number of physical records per line = 'b1' (fixed value)	b1
45	275 - 276	I2	Number of physical records per multi-channel line in this file = 'b1' (fixed value)	<p>b1</p> <p>This item means the number of records that compose BIL when the data observed by multi-channels are stored as BIL in a SAR signal data file. That is, when the signal data is stored as BIL of n channels and each channel composes one record, this item is set as “n”</p> <p>Channel definition of ALOS2 is as follows. Here the number of channels of dual pol. is twice as that of a single pol.</p> <p>Fine (Single Polarization) = 1 channel                      Spotlight, Ultra-fine/High-sensitive (Single pol.), Fine (Dual pol.), ScanSAR (Single pol.) = 2 channels                      Ultra-fine (Dual pol.), High-sensitive (Dual pol.)</p>



**Table 3.3-13 SAR Image file descriptor records (4/6)**

Field No.	Byte No.	Type	Description	Remarks
45 (cont.)				ScanSAR (Dual pol.), Full (Quad.) pol. = 4 channels In the case of ALOS2, set '1' (fixed value) because each polarization is stored in separate files.
46	277 - 280	I4	Number of bytes of prefix data per record Level 1.1 = 'b544' Level 1.5/3.1 = 'b192'	level 1.1: b544
47	281 - 288	I8	Number of bytes of SAR data per record	For level 1.1 products, each data record corresponds to 1 image range line. Each range line begins at the nearest-range pixel and ends at the farthest-range pixel.
48	289 - 292	I4	Number of bytes of suffix data per record = 'bbb0' (fixed value)	bbb0
49	293 - 296	A4	Prefix/suffix repeat flag = 'bbbb' (fixed value)	bbbb
<b>PREFIX/SUFFIX DATA LOCATORS</b>				
50	297 - 304	A8	Sample data line number locator = 'bb13b4PB' 'P': Prefix, 'S': Suffix 'A': ASCII, 'B': Binary, 'N': Numeric	bb13b4PB (Data line number location) 4 bytes from 13 <sup>th</sup> byte in signal data record
51	305 - 312	A8	SAR channel number locator = 'bb49b2PB'	bb49b2PB (SAR channel ID location)
52	313 - 320	A8	Time of SAR data line locator = 'bb45b4PB'	bb45b4PB (Description position of sensor acquiring milli-seconds)
53	321 - 328	A8	Left-fill count locator = 'bb21b4PB'	bb21b4PB (Description position of number of left-fill)
54	329 - 336	A8	Right-fill count locator = 'bb29b4PB'	bb29b4PB (Description position of number of right-fill)
55	337 - 340	A4	Pad pixels present indicator = 'bbbb'	bbbb
56	341 - 368	A28	Blanks	bbbbbbbbbbbbbbbbbbbbbbbbbbbb
57	369 - 376	A8	SAR data line quality code locator = 'bb97b4PB'	bb97b4PB (Invalid line flag location)

**Table 3.3-13 SAR Image file descriptor records (5/6)**

Field No.	Byte No.	Type	Description	Remarks
58	377 - 384	A8	Calibration information field locator = 'bbbbbbbb'	bbbbbbbb
59	385 - 392	A8	Gain values field locator = 'bbbbbbbb'	bbbbbbbb
60	393 - 400	A8	Bias values field locator = 'bbbbbbbb'	bbbbbbbb
61	401 - 428	A28	SAR data format type indicator Level 1.1 = 'COMPLEX*8bbbbbbbbbbbbbbbbbb' Level 1.5/3.1 = 'UNSIGNEDbINTEGER*2bbbbbbbbbb'	'UNSIGNEDbINTEGER*2bbbbbbbbbb"IU2b' : 2-bytes unsigned integer 'COMPLEX*8bbbbbbbbbbbbbbbbbb"C*8b' : The front half of the 8 bytes field (4 bytes) is two complement notations. Including real value of floating point type, rear half of that is complex representation including imaginary part. And undefined data is stored 0 values.
62	429 - 432	A4	SAR data format type code Level 1.1 = 'C*8b' Level 1.5/3.1 = 'IU2b'	
63	433 - 436	I4	Number of left fill bits within pixel = 'bbb0'	
64	437 - 440	I4	Number of right fill bits within pixel = 'bbb0'	bbb0
65	441 - 448	I8	Maximum data range of pixel (starting from 0) Level 1.1 = Blank ('bbbbbbbb') Level 1.5/3.1 = 'bbb65535'	
66	449 - 452	I4	ScanSAR level 1.1 (SPECAN method): Number of burst data in this file (starting from 1) Except ScanSAR level 1.1(SPECAN method): Blanks	For ScanSAR level 1.1(SPECAN method), set number of burst data in image file. Refer to 5.2 Except ScanSAR level 1.1(SPECAN method), set blanks.
67	453 - 456	I4	ScanSAR level 1.1(SPECAN method): Number of lines per one burst (starting from 1) Except ScanSAR level 1.1(SPECAN method): Blanks	For ScanSAR level 1.1, set number of lines per one burst data (number of lines is the same as each burst data). Refer to 5.2 Except ScanSAR level 1.1 (SPECAN method), set blanks.

**Table 3.3-13 SAR Image file descriptor records (6/6)**

Field No.	Byte No.	Type	Description	Remarks
			<b>SCANSAR BURST DATA INFORMATION</b>	
68	457 – 460	I4	ScanSAR level 1.1 (SPECAN method): Number of overlap lines with adjacent bursts (starting from 0) Except ScanSAR level 1.1 (SPECAN method) Blanks	For ScanSAR level 1.1 (SPECAN method), set number of overlap lines of adjacent burst (If no overlap lines, set 0). Refer to 5.2. Except ScanSAR level 1.1 (SPECAN method), set blanks.
69	461 – 720	A260	Blanks	Blanks (b*272)

**Table 3.3-14 Signal data records (1/5)**

Field No.	Byte No.	Type	Description	Remarks
1	1 - 4	B4	Record sequence number = 2, 3, ...) <sub>10</sub>	Level 1.1 has this record.
2	5 - 5	B1	1 <sup>st</sup> record sub-type code = 50) <sub>10</sub>	32h
3	6 - 6	B1	Record type code = 10) <sub>10</sub>	0Ah
4	7 - 7	B1	2 <sup>nd</sup> record sub-type code = 18) <sub>10</sub>	12h
5	8 - 8	B1	3 <sup>rd</sup> record sub-type code = 20) <sub>10</sub>	14h
6	9 - 12	B4	Record length	
<b>PREFIX DATA-GENERAL INFORMATION</b>				
7	13 - 16	B4	SAR image data line number = 1, 2, 3 ...) <sub>10</sub>	
8	17 - 20	B4	SAR image data record index = 1) <sub>10</sub> (fixed value) (indicates the record sequence number in the image line)	
9	21 - 24	B4	Actual count of left-fill pixels = 0) <sub>10</sub> (fixed value)	
10	25 - 28	B4	Actual count of data pixels	For level 1.1 products, actual count of data pixels corresponds to the number of 1 image range pixels. Each range line begins at the nearest-range pixel and ends at the farthest-range pixel.
11	29 - 32	B4	Actual count of right-fill pixels = 0) <sub>10</sub>	
<b>PREFIX DATA-SENSOR PARAMETERS</b>				
12	33 - 36	B4	Sensor parameters update flag = 0) <sub>10</sub>	
13	37 - 40	B4	Sensor acquisition year Scene start line year	
14	41 - 44	B4	Sensor acquisition day of year Scene start line day of year	
15	45 - 48	B4	Sensor acquisition milli-seconds of day	

**Table 3.3-14 Signal data records (2/5)**

Field No.	Byte No.	Type	Description	Remarks
16	49 - 50	B2	SAR channel ID Single polarization = 1) <sub>10</sub> Dual polarization = 2) <sub>10</sub> Full (Quad.) pol. = 4) <sub>10</sub>	0001h
17	51 - 52	B2	SAR channel code = 0) <sub>10</sub> L = 0) <sub>10</sub> S = 1) <sub>10</sub> C = 2) <sub>10</sub> X = 3) <sub>10</sub> KU = 4) <sub>10</sub> KA = 5) <sub>10</sub>	0000h
18	53 - 54	B2	Transmitted pulse polarization Horizontal polarization (H) = 0) <sub>10</sub> Vertical polarization (V) = 1) <sub>10</sub>	0000h
19	55 - 56	B2	Received pulse polarization H = 0) <sub>10</sub> V = 1) <sub>10</sub>	0000h
20	57 - 60	B4	PRF[mHz]	
21	61 - 64	B4	Scan ID ScanSAR = 1 to 7) <sub>10</sub> Except ScanSAR = 0) <sub>10</sub> (fixed value)	For ScanSAR level 1.1, set scan number. Refer to 5.2. Except ScanSAR level 1.1, set 0.
22	65 - 66	B2	Onboard range compressed flag = 0) <sub>10</sub> NO = 0) <sub>10</sub> YES = 1) <sub>10</sub>	0000h

A

**Table 3.3-14 Signal data records (3/5)**

Field No.	Byte No.	Type	Description	Remarks
23	67 - 68	B2	Chirp type designator LINEAR FM CHIRP = 0) <sub>10</sub> PHASE MODULATORS = 1) <sub>10</sub>	0000h
24	69 - 72	B4	Chirp length (pulse width) [nsec]	(Chirp length)
25	73 - 76	B4	Chirp constant coefficient [Hz] = Nominal value	(Chirp constant coefficient)
26	77 - 80	B4	Chirp linear coefficient [Hz/μsec] = Nominal value	(Chirp linear coefficient)
27	81 - 84	B4	Chirp quadratic coefficient [Hz/μsec <sup>2</sup> ] = Nominal value	(Chirp quadratic coefficient)
28	85 - 92	B8	Sensor acquisition micro-seconds of day	
29	93 - 96	B4	Receiver gain [dB] = Nominal value	(Receiver gain)
30	97 - 100	B4	Invalid line flag NO. (Effective line) = 0) <sub>10</sub> YES (Loss line) = 1) <sub>10</sub>	
31	101 - 104	B4	Electronic elevation angle at nadir of antenna [deg]	
32	105 - 108	B4	Mechanical elevation angle at nadir of antenna [deg]	
33	109 - 112	B4	Electronic antenna squint angle [deg]	
34	113 - 116	B4	Mechanical antenna squint angle [deg]	
35	117 - 120	B4	Slant range to 1st data sample [m]	
36	121 - 124	B4	Data record window position (SAMPLE DELAY[nsec])	
37	125 - 128	B4	Spare = Blanks (0: NULL)	Blanks (0: NULL)

C

**Table 3.3-14 Signal data records (4/5)**

Field No.	Byte No.	Type	Description	Remarks
			<b>PREFIX DATA-PLATFORM REFERENCE INFORMATION</b>	
38	129 - 132	B4	Platform position parameters update flag = 0) <sub>10</sub> (fixed value) Repeat = 0) <sub>10</sub> Update = 1) <sub>10</sub>	
39	133 - 136	B4	Platform latitude [1/1,000,000 deg] = 0) <sub>10</sub>	Blanks (0: NULL)
40	137 - 140	B4	Platform longitude [1/1,000,000 deg] = 0) <sub>10</sub>	Blanks (0: NULL)
41	141 - 144	B4	Platform altitude [m] = 0) <sub>10</sub>	Blanks (0: NULL)
42	145 - 148	B4	Platform ground speed [cm/sec] = 0) <sub>10</sub>	Blanks (0: NULL)
43	149 - 160	3B4	Platform velocity X', Y', Z'[cm/sec] = 0) <sub>10</sub>	Blanks (0: NULL)
44	161 - 172	3B4	Platform acceleration X'', Y'', Z''[cm/sec <sup>2</sup> ] = 0) <sub>10</sub>	Blanks (0: NULL)
45	173 - 176	B4	Platform track angle [1/1,000,000 deg] = 0) <sub>10</sub>	Blanks (0: NULL)
46	177 - 180	B4	Platform true track angle [1/1,000,000 deg] = 0) <sub>10</sub>	Blanks (0: NULL)
47	181 - 184	B4	Platform pitch angle [1/1,000,000 deg] = 0) <sub>10</sub>	Blanks (0: NULL)
48	185 - 188	B4	Platform roll angle [1/1,000,000 deg] = 0) <sub>10</sub>	Blanks (0: NULL)
49	189 - 192	B4	Platform yaw angle [1/1,000,000 deg] = 0) <sub>10</sub>	Blanks (0: NULL)
			<b>PREFIX DATA-SENSOR/FACILITY SPECIFIC AUXILIARY DATA</b>	
50	193 - 196	B4	Latitude of 1 <sup>st</sup> pixel [1/1,000,000 deg]	
51	197 - 200	B4	Latitude of center-pixel [1/1,000,000 deg]	The latitude at M/2th pixel is set. (M: number of pixels)
52	201 - 204	B4	Latitude of last pixel [1/1,000,000 deg]	
53	205 - 208	B4	Longitude of 1 <sup>st</sup> pixel [1/1,000,000 deg]	
54	209 - 212	B4	Longitude of center-pixel [1/1,000,000 deg]	The longitude at M/2th pixel is set. (M: number of pixels)
55	213 - 216	B4	Longitude of last pixel [1/1,000,000 deg]	

**Table 3.3-14 Signal data records (5/5)**

Field No.	Byte No.	Type	Description	Remarks
<b>SCANSAR BURST DATA PARAMETERS</b>				
56	217 – 220	B4	ScanSAR level 1.1 (SPECAN method): Burst number = starting from 0) <sub>10</sub> Except ScanSAR level 1.1 (SPECAN method): Blanks = 0) <sub>10</sub>	ScanSAR level 1.1 (SPECAN method), set 0 at first burst in image file, and continue 1, 2, 3... Except ScanSAR level 1.1 (SPECAN method), set blanks (0).
57	221 – 224	B4	ScanSAR level 1.1 (SPECAN method): Line number in this burst = starting from 0) <sub>10</sub> Except ScanSAR level 1.1 (SPECAN method) Blanks = 0) <sub>10</sub>	Except ScanSAR level 1.1 (SPECAN method), set line number of 1, 2, 3... in this burst. Except ScanSAR level 1.1 (SPECAN method) is blanks (0).
58	225 - 284	B60	Blanks = 0) <sub>10</sub>	
59	285 - 288	B4	ALOS2 frame number = 0) <sub>10</sub>	
60	289 - 544	B256	PALSAR auxiliary data= 0) <sub>10</sub>	
<b>SAR RAW SIGNAL DATA</b>				
	545 - i	jBk	SAR data i: number of bytes of data + 544 j: number of pixels on this record k: pixel size [8byte]	Repeat by the number of pixels



**Table 3.3-15 Processed data records (1/4)**

Field No.	Byte No.	Type	Description	Remarks
1	1 - 4	B4	Record sequence number = 2, 3, ...)10	Only level 1.5/3.1 has this record.
2	5 - 5	B1	1 <sup>st</sup> record sub-type code = 50)10	
3	6 - 6	B1	Record type code = 11)10	
4	7 - 7	B1	2 <sup>nd</sup> record sub-type code = 18)10	
5	8 - 8	B1	3 <sup>rd</sup> record sub-type code = 20)10	
6	9 - 12	B4	Record length	
<b>PREFIX DATA-GENERAL INFORMATION</b>				
7	13 - 16	B4	SAR image data line number = 1, 2, 3 ...)10	
8	17 - 20	B4	SAR image data record index = 1)10 (fixed value) (indicates the record sequence number in the same line)	
9	21 - 24	B4	Actual count of left-fill pixels = 0)10 (fixed value)	
10	25 - 28	B4	Actual count of data pixels	
11	29 - 32	B4	Actual count of right-fill pixels = 0)10	
<b>PREFIX DATA-SENSOR PARAMETERS</b>				
12	33 - 36	B4	Sensor parameters update flag = 0)10	
13	37 - 40	B4	Sensor acquisition year Year of scene start line	
14	41 - 44	B4	Sensor acquisition day of year Scene start day of year	
15	45 - 48	B4	Sensor acquisition milliseconds of day = 0)10	

**Table 3.3-15 Processed data records (2/4)**

Field No.	Byte No.	Type	Description	Remarks
16	49 - 50	B2	SAR channel ID Single polarization = 1) <sub>10</sub> Dual polarization = 2) <sub>10</sub> Full (Quad.) pol. = 4) <sub>10</sub>	
17	51 - 52	B2	SAR channel code = 0) <sub>10</sub> L = 0) <sub>10</sub> S = 1) <sub>10</sub> C = 2) <sub>10</sub> X = 3) <sub>10</sub> KU = 4) <sub>10</sub> KA = 5) <sub>10</sub>	
18	53 - 54	B2	Transmitted polarization Horizontal polarization (H) = 0) <sub>10</sub> Vertical polarization (V) = 1) <sub>10</sub>	
19	55 - 56	B2	Received pulse polarization H = 0) <sub>10</sub> V = 1) <sub>10</sub>	
20	57 - 60	B4	PRF[mHz] Except ScanSAR mode = The same through the one scene ScanSAR = 0) <sub>10</sub> (fixed value)	
21	61 - 64	B4	Scan number = 0) <sub>10</sub> (fixed value)	

A

**Table 3.3-15 Processed data records (3/4)**

Field No.	Byte No.	Type	Description	Remarks
22	65 – 68	B4	Slant range to 1 <sup>st</sup> pixel [m]	
23	69 – 72	B4	Slant range to mid-pixel [m]	
24	73 – 76	B4	Slant range to last-pixel [m]	
25	77 – 80	B4	Doppler centroid value at 1 <sup>st</sup> pixel [1/1,000Hz]	
26	81 – 84	B4	Doppler centroid value at mid-pixel [1/1,000Hz]	
27	85 – 88	B4	Doppler centroid value at last pixel [1/1,000Hz]	
28	89 – 92	B4	Azimuth FM rate of 1 <sup>st</sup> pixel [Hz/msec]	
29	93 – 96	B4	Azimuth FM rate of mid-pixel [Hz/msec]	
30	97 - 100	B4	Azimuth FM rate of last pixel [Hz/msec]	
31	101 - 104	B4	Look angle of nadir [1/1,000,000 deg] = 0) <sub>10</sub>	
32	105 - 108	B4	Azimuth squint angle [1/1,000,000 deg] = 0) <sub>10</sub>	
33	109 – 128	B4	Blanks = 0) <sub>10</sub>	
<b>PREFIX DATA-GEOGRAPHIC REFERENCE INFO.</b>				
34	129 – 132	B4	Geographic ref. Parameter update flag = 0) <sub>10</sub>	
35	133 - 136	B4	Latitude of 1 <sup>st</sup> pixel [1/1,000,000 deg]	
36	137 - 140	B4	Latitude of mid-pixel [1/1,000,000 deg]	The latitude at M/2th pixel is set. (M: number of pixels)
37	141 - 144	B4	Latitude of last pixel [1/1,000,000 deg]	
38	145 - 148	B4	Longitude of 1 <sup>st</sup> pixel [1/1,000,000 deg]	
39	149 – 152	B4	Longitude of mid-pixel [1/1,000,000 deg]	The longitude at M/2th pixel is set. (M: number of pixels)
40	153 – 156	B4	Longitude of last pixel [1/1,000,000 deg]	
41	157 - 160	B4	Northing of 1 <sup>st</sup> pixel [m]	
42	161 – 164	B4	Blanks = 0) <sub>10</sub>	
43	165 – 168	B4	Northing of last pixel [m]	
44	169 – 172	B4	Easting of 1 <sup>st</sup> pixel [m]	
45	173 – 176	B4	Blanks = 0) <sub>10</sub>	
46	177 – 180	B4	Easting of last pixel [m]	

**Table 3.3-15 Processed data records (4/4)**

Field No.	Byte No.	Type	Description	Remarks
47	181 - 184	B4	Line heading (orientation of the perpendicular to the data line center relative to true north) [1/1,000,000 deg]	
48	185 - 192	B8	Blanks = 0) <sub>10</sub>	
			SAR PROCESSED DATA	
	193 - i	jBk	SAR processed data i: number of bytes of data + 192 j: number of pixels on this record k: size of pixel in bytes [2byte]	
			SUFFIX DATA	
		0*B	Processing Facility specific details	

**Table 3.3-16 SAR Trailer file descriptor (1/4)**

Field No.	Byte No.	Type	Description	Remarks
1	1 - 4	B4	Record number = 1) <sub>10</sub>	00000001h
2	5 - 5	B1	1 <sup>st</sup> record sub-type code = 63) <sub>10</sub>	3Fh
3	6 - 6	B1	Record type code = 192) <sub>10</sub>	C0h
4	7 - 7	B1	2 <sup>nd</sup> record sub-type code = 18) <sub>10</sub>	12h
5	8 - 8	B1	3 <sup>rd</sup> record sub-type code = 18) <sub>10</sub>	12h
6	9 - 12	B4	Record length = 720) <sub>10</sub>	000002D0h
7	13 - 14	A2	ASCII/EBCDIC code = 'Ab': ASCII	Ab
8	15 - 16	A2	Blanks	bb
9	17 - 28	A12	Format control document ID = 'CEOS-SARbbbb'	CEOS-SARbbbb
10	29 - 30	A2	Format control document revision number = 'bA'	bA
11	31 - 32	A2	Record format revision level = 'bA'	bA
12	33 - 44	A12	Software release & revision = 'NNN.NNNbbbb' 001.000, 001.001, ... 001.100, ... 002.000	001.000bbbb
13	45 - 48	I4	Number of files = 'bbb1'	bbb1
14	49 - 64	A16	File ID = 'MMNbSSSTFFFFbbbb' MM: Mission ID(ALOS2='AL')(*) N: Mission number (=2')(*) SSS: Sensor ID (SAR='SAR')(*) T: Processing level code Level 1.0 = 'A' Level 1.1 = 'B' Level 1.5 = 'C' Level 3.1 = 'D' FFFF : Tile Type(*) Leader file = 'SARL' Image file = 'IMOP' Trailer file = 'SART'	AL2bSARASARTbbbb
15	65 - 68	A4	Record sequence and location type flag = 'FSEQ'	FSEQ
16	69 - 76	I8	Sequence number location = 'bbbbbb1'	bbbbbb1 (Record number location)

A

**Table 3.3-16 SAR Trailer file descriptor (2/4)**

Field No.	Byte No.	Type	Description	Remarks
17	77 - 80	I4	Sequence number field length = 'bbb4'	bbb4 (Record number field length)
18	81 - 84	A4	Record code and location type flag = 'FTYP'	FTYP
19	85 - 92	I8	Record code location = 'bbbbbbb5'	bbbbbbb5 (Record code location)
20	93 - 96	I4	Record code field length = 'bbb4'	bbb4 (Record code field length)
21	97 - 100	A4	Record length and location type flag = 'FLGT'	FLGT
22	101 - 108	I8	Record length location = 'bbbbbbb9'	bbbbbbb9 (Record length location)
23	109 - 112	I4	Record length field length = 'bbb4'	bbb4 (Record length field length)
24	113 - 180	A68	Blanks	Blanks (b*68)
25	181 - 186	I6	Number of data set summary records = 'bbbbbb0'	bbbbbb0
26	187 - 192	I6	Data set summary record length = 'bbbbbb0'	bbbbbb0
27	193 - 198	I6	Number of map projection data records = 'bbbbbb0'	bbbbbb0
28	199 - 204	I6	Map projection record length = 'bbbbbb0'	bbbbbb0
29	205 - 210	I6	Number of platform position data records = 'bbbbbb0'	bbbbbb0
30	211 - 216	I6	Platform position record length = 'bbbbbb0'	bbbbbb0
31	217 - 222	I6	Number of attitude data records = 'bbbbbb0'	bbbbbb0
32	223 - 228	I6	Attitude data record length = 'bbbbbb0'	bbbbbb0
33	229 - 234	I6	Number of radiometric data records = 'bbbbbb0'	bbbbbb0
34	235 - 240	I6	Radiometric record length = 'bbbbbb0'	bbbbbb0
35	241 - 246	I6	Number of radiometric compensation records = 'bbbbbb0'	bbbbbb0
36	247 - 252	I6	Radiometric compensation record length = 'bbbbbb0'	bbbbbb0
37	253 - 258	I6	Number of data quality summary records = 'bbbbbb0'	bbbbbb0
38	259 - 264	I6	Data quality summary record length = 'bbbbbb0'	bbbbbb0
39	265 - 270	I6	Number of data histograms records = 'bbbbbb0'	bbbbbb0
40	271 - 276	I6	Data histogram record length = 'bbbbbb0'	bbbbbb0
41	277 - 282	I6	Number of range spectra records = 'bbbbbb0'	bbbbbb0
42	283 - 288	I6	Range spectra record length = 'bbbbbb0'	bbbbbb0
43	289 - 294	I6	Number of DEM descriptor records = 'bbbbbb0'	bbbbbb0
44	295 - 300	I6	DEM descriptor record length = 'bbbbbb0'	bbbbbb0
45	301 - 306	I6	Number of Radar parameter update records = 'bbbbbb0'	bbbbbb0

**Table 3.3-16 SAR Trailer file descriptor (3/4)**

Field No.	Byte No.	Type	Description	Remarks
46	307 - 312	I6	Radar parameter update record length = 'bbbbbb0'	bbbbbb0
47	313 - 318	I6	Number of Annotation data records = 'bbbbbb0'	bbbbbb0
48	319 - 324	I6	Annotation data record length = 'bbbbbb0'	bbbbbb0
49	325 - 330	I6	Number of detail processing records = 'bbbbbb0'	bbbbbb0
50	331 - 336	I6	Detail processing record length = 'bbbbbb0'	bbbbbb0
51	337 - 342	I6	Number of Calibration records = 'bbbbbb0'	bbbbbb0
52	343 - 348	I6	Calibration record length = 'bbbbbb0'	bbbbbb0
53	349 - 354	I6	Number of GCP records = 'bbbbbb0'	bbbbbb0
54	355 - 360	I6	GCP record length = 'bbbbbb0'	bbbbbb0
55	361 - 420	10A6	Spare = Blanks	Blanks
56	421 - 426	I6	Number of facility data (1) records = 'bbbbbb0'	bbbbbb0
57	427 - 434	I8	Facility data (1) record length = 'bbbbbbb0'	bbbbbbb0
58	435 - 440	I6	Number of facility data (2) records = 'bbbbbb0'	bbbbbb0
59	441 - 448	I8	Facility data (2) record length = 'bbbbbbb0'	bbbbbbb0
60	449 - 454	I6	Number of facility data (3) records = 'bbbbbb0'	bbbbbb0
61	455 - 462	I8	Facility data (3) record length = 'bbbbbbb0'	bbbbbbb0
62	463 - 468	I6	Number of facility data (4) records = 'bbbbbb0'	bbbbbb0
63	469 - 476	I8	Facility data (4) record length = 'bbbbbbb0'	bbbbbbb0
64	477 - 482	I6	Number of facility data (5) records = 'bbbbbb0'	
65	483 - 490	I8	Facility data (5) record length = 'bbbbbbb0'	

**Table 3.3-16 SAR Trailer file descriptor (4/4)**

Field No.	Byte No.	Type	Description	Remarks
66	491 – 496	I6	Number of low resolution image data records ScanSAR L1.1 = 'bbbb5'~'bbbb7' (Scan number) Except ScanSAR L1.1 = 'bbbb1'	
67	497 – 504	I8	Low resolution image data 1 record length (Variable)	
68	505 - 510	I6	Number of pixels of low resolution image data 1 (Variable)	
69	511 - 516	I6	Number of lines of low resolution image data 1 (Variable)	
70	517 - 522	I6	Number of bytes per one sample of low resolution image data 1 = 'bbbb2'	
	523 – 522+26*(n-1)	26*(n-1)	Repetition of bytes 497 to 522 for the number of records(n) of section 66 <sup>th</sup>	
71	523+26*(n-1) - 720	A(720- (522+26 *(n-1)))	Blanks	



**Table 3.3-17 Low resolution image data records (1/1)**

Field No.	Byte No.	Type	Description	Remarks
1	1 - i	jBk	Low resolution image data for 16bit i: number of bytes of data j: number of pixels on this record k: size of pixel in bytes = 2	

**Table 3.3-18 Definition of items written in CEOS level 1.1/1.5/3.1 format (1/8)**

No.	Record	Location	Items	Definition
1	Text	17 - 56	Product ID	'PRODUCT: DDDEFFFGHIbbbbbbbbbbbbbbbbbbbb' DDD: Observation mode SBS: Spotlight mode UBS: Ultra-fine mode (Single pol.) UBD: Ultra-fine mode (Dual pol.) HBS: High-sensitive mode (Single pol.) HBD: High-sensitive mode (Dual pol.) HBQ: High-sensitive mode (Full (Quad.) pol.) FBS: Fine mode (Single pol.) FBD: Fine mode (Dual pol.) FBQ: Fine mode (Full (Quad.) pol.) WBS: ScanSAR nominal [14MHz] mode (Single pol.) WBD: ScanSAR nominal [14MHz] mode (Dual pol.) WWS: ScanSR nominal [28MHz] mode (Single pol.) WWD: ScanSAR nominal [28MHz] mode (Dual pol.) VBS: ScanSAR wide mode (Single pol.) VBD: ScanSAR wide mode (Dual pol.) E : Observation direction L: Left looking R: Right looking FFF: Processing level 1.0: Level 1.0 1.1: Level 1.1 1.5: Level 1.5 3.1: Level 3.1

**Table 3.3-18 Definition of items written in CEOS level 1.1/1.5/3.1 format (2/8)**

No.	Record	Location	Items	Definition
1	Text	17 - 56	Product ID	G : Processing option G: Geo-Coded R: Geo-Reference _ : Not specified (Underscore) H : Map projection U: UTM P: PS M: MER L: LCC _ : Not specified (Underscore) I : Orbit direction (*) A: Ascending D: Descending
2	Text data set summary	157 - 196 21 - 52	Scene ID	'ORBITb: AAAAABBBBBBCCCC-YYMMDDbbbbbbbbbbb' AAAAA: Satellite ID ('ALOS2') BBBBB: Orbit accumulation number of a scene center CCCC: Scene frame number of a scene center - : Separator (hyphen) YYMMDD : Observation date of a scene center (YY: lower 2 figures of a year, MM: month, DD: day)
3	Data set summary	711 - 726	Sampling frequency	Sampling frequency of auxiliary data first frame Relationships between product setting values (left) and accurate values used by processing (right) are as follows: 1) (Setting value) 104.7915957[MHz]: (Accurate value) 1.047915957140240E+08[Hz] 2) (Setting value) 52.3957979[MHz]: (Accurate value) 5.239579785701190E+07[Hz] 3) (Setting value) 34.9305319[MHz]: (Accurate value) 3.493053190467460E+07[Hz] 4) (Setting value) 17.4652660[MHz]: (Accurate value) 1.746526595233730E+07[Hz]
4		727 - 742	Range gate	AD gate start delay of auxiliary data first frame [µsec]
5		743 - 758	Range pulse width	Pulse width of ALOS2 signal generator of auxiliary data first frame
6		759 - 762	Baseband conversion flag	YES/NOT: ALOS2 is baseband conversion (YES)
7		899 - 914	electronic boresight	Electronic boresight and mechanical boresight is the same definition (the same value)
8		915 - 930	mechanical boresight	Electronic boresight and mechanical boresight is the same definition (the same value)
9		931 - 934	Echo tracker On/Off	On/Off: ALOS2 is echo tracker = OFF

**Table 3.3-18 Definition of items written in CEOS level 1.1/1.5/3.1 format (3/8)**

No.	Record	Location	Items	Definition																					
10	Data set summary	935 - 950	PRF	Reciprocal of PRI of auxiliary data first frame (1/PRI)																					
11		983 - 998	Binary time code of satellite	Time reference of satellite (Tref)																					
12		999 - 1030	Clock time of satellite	Time ground reference: UTC (Tgref)																					
13		1031 - 1046	Satellite clock increment	Satellite clock counter period (Psc) Observation ground time for a satellite time counter is calculated using the following formula: Ground time (UTC) = Psc×(Tsc-Tref)+ Tgref																					
14		1767 - 1770	Calibration mode data location flag and star line number and end number	<p>In the case of no calibration data</p> <table border="1" style="margin-left: 40px;"> <tr> <td colspan="2" style="text-align: center;">Observation mode</td> </tr> <tr> <td colspan="2">Start line number of calibration mode at upper image = 0</td> </tr> <tr> <td colspan="2">End line number of calibration mode at upper image = 0</td> </tr> <tr> <td colspan="2">Start line number of calibration mode at bottom image = 0</td> </tr> <tr> <td colspan="2">End line number of calibration mode at bottom image = 0</td> </tr> </table> <p>In the case of including calibration data at the edge of upper image</p> <table border="1" style="margin-left: 40px;"> <tr> <td style="text-align: center;">l</td> <td style="text-align: center;">m</td> <td style="text-align: center;">n</td> </tr> <tr> <td style="text-align: center;">Calibration mode</td> <td colspan="2" style="text-align: center;">Observation mode</td> </tr> </table> <p>Start line number of calibration mode at upper image = 1 End line number of calibration mode at upper image = m Start line number of calibration mode at bottom image = 0 End line number of calibration mode at bottom image = 0</p> <p>In the case of including calibration data at the edge of bottom image</p> <table border="1" style="margin-left: 40px;"> <tr> <td style="text-align: center;">l</td> <td style="text-align: center;">m</td> <td style="text-align: center;">n</td> </tr> <tr> <td colspan="2" style="text-align: center;">Observation mode</td> <td style="text-align: center;">Calibration mode</td> </tr> </table> <p>Start line number of calibration mode at upper image = 0 End line number of calibration mode at upper image = 0 Start line number of calibration mode at bottom image = m End line number of calibration mode at bottom image = n</p>	Observation mode		Start line number of calibration mode at upper image = 0		End line number of calibration mode at upper image = 0		Start line number of calibration mode at bottom image = 0		End line number of calibration mode at bottom image = 0		l	m	n	Calibration mode	Observation mode		l	m	n	Observation mode	
Observation mode																									
Start line number of calibration mode at upper image = 0																									
End line number of calibration mode at upper image = 0																									
Start line number of calibration mode at bottom image = 0																									
End line number of calibration mode at bottom image = 0																									
l	m	n																							
Calibration mode	Observation mode																								
l	m	n																							
Observation mode		Calibration mode																							

**Table 3.3-18 Definition of items written in CEOS level 1.1/1.5/3.1 format (4/8)**

No.	Record	Location	Items	Definition												
14	Data set summary	1767 - 1770	Calibration mode data location flag and star line number and end number	<p>In the case of including calibration data at the edges of upper and bottom image</p> <table border="1"> <tr> <td>1</td> <td>n</td> </tr> <tr> <td colspan="2">Calibration mode</td> </tr> </table> <p>Start line number of calibration mode at upper image = 1            End line number of calibration mode at upper image = n            Start line number of calibration mode at bottom image = 1            End line number of calibration mode at bottom image = n</p> <p>or</p> <table border="1"> <tr> <td>1</td> <td>m1</td> <td>m2</td> <td>n</td> </tr> <tr> <td>Calibration mode</td> <td>Observation mode</td> <td>Calibration mode</td> <td></td> </tr> </table> <p>Start line number of calibration mode at upper image = 1            End line number of calibration mode at upper image = m1            Start line number of calibration mode at bottom image = m2            End line number of calibration mode at bottom image = n</p>	1	n	Calibration mode		1	m1	m2	n	Calibration mode	Observation mode	Calibration mode	
1		n														
Calibration mode																
1	m1	m2	n													
Calibration mode	Observation mode	Calibration mode														
15	1835 - 1838	Parameter auto-set table number	Parameter auto-set of observed auxiliary data acquired at first frame Table number													
16	1839 - 1854	Off-nadir angle	Actual value													

**Table 3.3-18 Definition of items written in CEOS level 1.1/1.5/3.1 format (5/8)**

No.	Record	Location	Items	Definition
17	Data set summary	1855 - 1858	Antenna beam number	The number corresponding to each off-nadir angle
18	Platform position data	4101 - 4101	Leap second flag	This flag is "1" if a scene includes line times before and after the TAI-UTC change time.
19	SAR data file descriptor	187 - 192	SAR data record length	
20		275 - 276	Number of physical records per multi-channel in this file	<p>This item means the number of records that compose BIL when the data observed by multi-channels are stored as BIL in a SAR signal data file. That is, when the signal data is stored as BIL of n channels and each channel composes one record, this item is set as "n"</p> <p>Channel definition of ALOS2 is as follows. Here the number of channels of dual pol. is twice as that of a single pol.            Fine (Single pol. ) = 1 channel            Spotlight, Ultra-fine/High-sensitive (Single pol. ), Fine (Dual pol. ), SacnSAR (Single pol. ) = 2 channels            Ultra-fine (Dual pol.), High-sensitive (Dual pol.), ScanSAR (Dual pol.), Full pol. = 4 channels</p> <p>In the case of ALOS2, set '1' (fixed value) because each polarization is stored in separate files.</p>

**Table 3.3-18 Definition of items written in CEOS level 1.1/1.5/3.1 format (6/8)**

No.	Record	Location	Items	Definition																								
21	Signal data	13 - 16	SAR image data line number	Count up every lines, one frame as one line Default value is 1 in all files																								
22		17 - 20	SAR image data record index	It means counter if one line data across multi records. Therefore, when 1 line composed of three lines is as follows: <table style="margin-left: auto; margin-right: auto; border-collapse: collapse;"> <thead> <tr> <th></th> <th style="text-align: center;">SAR line number</th> <th style="text-align: center;">SAR record index</th> </tr> </thead> <tbody> <tr> <td>1<sup>st</sup> record</td> <td style="text-align: center;">1</td> <td style="text-align: center;">1</td> </tr> <tr> <td>2<sup>nd</sup> record</td> <td style="text-align: center;">1</td> <td style="text-align: center;">2</td> </tr> <tr> <td>3<sup>rd</sup> record</td> <td style="text-align: center;">1</td> <td style="text-align: center;">3</td> </tr> <tr> <td>4<sup>th</sup> record</td> <td style="text-align: center;">2</td> <td style="text-align: center;">1</td> </tr> <tr> <td>5<sup>th</sup> record</td> <td style="text-align: center;">2</td> <td style="text-align: center;">2</td> </tr> <tr> <td>6<sup>th</sup> record</td> <td style="text-align: center;">2</td> <td style="text-align: center;">3</td> </tr> <tr> <td>7<sup>th</sup> record</td> <td style="text-align: center;">3</td> <td style="text-align: center;">1</td> </tr> </tbody> </table> ALOS2 is 1(fixed value).		SAR line number	SAR record index	1 <sup>st</sup> record	1	1	2 <sup>nd</sup> record	1	2	3 <sup>rd</sup> record	1	3	4 <sup>th</sup> record	2	1	5 <sup>th</sup> record	2	2	6 <sup>th</sup> record	2	3	7 <sup>th</sup> record	3	1
		SAR line number	SAR record index																									
1 <sup>st</sup> record	1	1																										
2 <sup>nd</sup> record	1	2																										
3 <sup>rd</sup> record	1	3																										
4 <sup>th</sup> record	2	1																										
5 <sup>th</sup> record	2	2																										
6 <sup>th</sup> record	2	3																										
7 <sup>th</sup> record	3	1																										
23	21 - 24 25 - 28 29 - 32	Actual number of left-fill, actual number of data pixels, actual pixel number of right-fill	<table border="1" style="width: 100%; border-collapse: collapse; text-align: center;"> <tr> <td rowspan="2" style="width: 25%; vertical-align: middle;">Prefix data</td> <td colspan="3" style="border: none;">← Bytes length of SAR data per record →</td> </tr> <tr> <td style="width: 33%;">Observation data</td> <td style="width: 15%;">Undefined data</td> <td style="width: 15%;">Dummy data</td> </tr> <tr> <td style="border: none;"></td> <td style="border: none;">← Actual number of data pixels = Number of samples →</td> <td colspan="2" style="border: none;">Actual number of pixels of right-filled = (SAR data length - Number of samples *2)/2</td> </tr> </table> Actual number of pixels of left-filled is 0 (fixed value).	Prefix data	← Bytes length of SAR data per record →			Observation data	Undefined data	Dummy data		← Actual number of data pixels = Number of samples →	Actual number of pixels of right-filled = (SAR data length - Number of samples *2)/2															
Prefix data	← Bytes length of SAR data per record →																											
	Observation data	Undefined data	Dummy data																									
	← Actual number of data pixels = Number of samples →	Actual number of pixels of right-filled = (SAR data length - Number of samples *2)/2																										

**Table 3.3-18 Definition of items written in CEOS level 1.1/1.5/3.1 format (7/8)**

No.	Record	Location	Items	Definition
24	Signal data	97 - 100	Invalid line flag	Invalid line flag is where: 0: NO. (Normal data) 1: YES (The line is treated as a loss line) When extracting ALOS2 frame data, If I or Q has 1 or more packet loss (discontinuity in the packet sequence counter), this flag is YES.
25		117 - 120	Slant range to the first data	Calculation formula of near range is where: $R_n = T_0 \times c / 2$ $T_0 = \text{Trange0} + n \times \text{Tpri} + \text{T}_{\text{ADSTART}} + \text{Tchdelay}$ Rn: Near range distance T0: Time to receiving from transmitting c: Speed of light (Constant) Trange0: Time corrected range zero n: Number of pulses received round trip (including in auxiliary data) Tpri: PRI (including in auxiliary data) T <sub>ADSTART</sub> : AD gate start delay (including in auxiliary data) Tchdelay: Delay time between CHs



**Table 3.3-18 Definition of items written in CEOS level 1.1/1.5/3.1 format (8/8)**

No.	Record	Location	Items	Definition
26	Signal data	121 - 124	Data record window location (SAMPLEDELAY[nsec])	SAMPLEDELAY is calculated using the following formula: $T_{sdlay} = T_{range0} + T_{ADSTART} + T_{chdelay}$ T <sub>range0</sub> : range zero corrected time T <sub>ADSTART</sub> : AD gate start delay (including auxiliary data) T <sub>chdelay</sub> : Delay time between CH
27		285 - 288	ALOS2 frame number	Extract and set a frame number per each frame.
28		289 - 544	Auxiliary data	Extract and set (raw) auxiliary data per each frame.
29		545 -	SAR data	“SAR data” is shown in No. 19, it is composed of ALOS2 data, undefined data and dummy data. Dummy data is filled with 0 (NULL) values until it reaches the fixed value frame length in level 1.0 processing.

**Table 3.3-19 Relationship between Antenna Beam Number and Parameters  
for Spotlight Mode (Single Polarization)**

Beam No.	Off-nadir Angle [deg.]	Nominal PRF [Hz]	Max PRF [Hz]	Sampling Frequency [Hz]	No. of Bytes per Pixel [byte]
1 (8.0)	7.3	1853	2670	104.8	2
2 (15.0)	13.6	1853	2670	104.8	2
3 (20.0)	18.1	1853	2670	104.8	2
4 (25.0)	22.6	1853	2670	104.8	2
5 (30.0)	27.1	1853	2670	104.8	2
6 (35.0)	31.5	1853	2670	104.8	2
7 (37.0)	33.22	1853	2670	104.8	2
8 (40.0)	35.8	1853	2670	104.8	2
9 (45.0)	40.1	1853	2670	104.8	2
10 (50.0)	44.2	1853	2670	104.8	2
11 (55.0)	48.2	1853	2670	104.8	2
12 (60.0)	52.0	1853	2670	104.8	2
13 (65.0)	55.6	1853	2670	104.8	2
14 (70.0)	58.8	1853	2670	104.8	2

\* The values in brackets show the incidence angles at beam center. Here, the incidence angles are described 18.0, 37.0 degrees and the values in every 5 degrees from 15 to 70 degrees because the spotlight mode does not have the concept of the number of beams.

**Table 3.3-20 Relationship between Antenna Beam Number and Parameters  
for Ultra Fine Mode (Single/Dual Polarization)**

Beam No.	Off-nadir Angle [deg.]	Nominal PRF [Hz]	Max PRF [Hz]	Sampling Frequency [Hz]	No. of Bytes per Pixel [byte]
1	9.6	1626	1970	104.8	2
2	13.9	1626	1970	104.8	2
3	18.0	1626	1970	104.8	2
4	21.9	1626	1970	104.8	2
5	25.6	1626	1970	104.8	2
6	29.1	1626	1970	104.8	2
7	32.4	1626	1970	104.8	2
8	35.4	1626	1970	104.8	2
9	38.2	1626	1970	104.8	2
10	40.6	1626	1970	104.8	2
11	42.7	1626	1970	104.8	2
12	44.7	1626	1970	104.8	2
13	46.4	1626	1970	104.8	2
14	48.0	1626	1970	104.8	2
15	49.5	1626	1970	104.8	2
16	50.9	1626	1970	104.8	2
17	52.1	1626	1970	104.8	2
18	53.3	1626	1970	104.8	2
19	54.3	1626	1970	104.8	2
20	55.3	1626	1970	104.8	2
21	56.2	1626	1970	104.8	2
22	57.0	1626	1970	104.8	2
23	57.7	1626	1970	104.8	2
24	58.4	1626	1970	104.8	2

**Table 3.3-21 Relationship between Antenna Beam Number and Parameters  
for High-sensitive Mode (Single/Dual Polarization)**

Beam No.	Off-nadir Angle [deg.]	Nominal PRF [Hz]	Max PRF [Hz]	Sampling Frequency [Hz]	No. of Bytes per Pixel [byte]
1	9.6	1477	1570	52.4	2
2	13.9	1477	1570	52.4	2
3	18.0	1477	1570	52.4	2
4	21.9	1477	1570	52.4	2
5	25.6	1477	1570	52.4	2
6	29.1	1477	1570	52.4	2
7	32.4	1477	1570	52.4	2
8	35.4	1477	1570	52.4	2
9	38.2	1477	1570	52.4	2
10	40.6	1477	1570	52.4	2
11	42.7	1477	1570	52.4	2
12	44.7	1477	1570	52.4	2
13	46.4	1477	1570	52.4	2
14	48.0	1477	1570	52.4	2
15	49.5	1477	1570	52.4	2
16	50.9	1477	1570	52.4	2
17	52.1	1477	1570	52.4	2
18	53.3	1477	1570	52.4	2
19	54.3	1477	1570	52.4	2
20	55.3	1477	1570	52.4	2
21	56.2	1477	1570	52.4	2
22	57.0	1477	1570	52.4	2
23	57.7	1477	1570	52.4	2
24	58.4	1477	1570	52.4	2

**Table 3.3-22 Relationship between Antenna Beam Number and Parameters  
for Fine Mode (Single/Dual Polarization)**

Beam No.	Off-nadir Angle [deg.]	Nominal PRF [Hz]	Max PRF [Hz]	Sampling Frequency [Hz]	No. of Bytes per Pixel [byte]
1	10.3	1861	2180	34.9	2
2	16.0	1861	2180	34.9	2
3	21.4	1861	2180	34.9	2
4	26.4	1861	2180	34.9	2
5	30.9	1861	2180	34.9	2
6	34.9	1861	2180	34.9	2
7	38.4	1861	2180	34.9	2
8	41.0	1861	2180	34.9	2
9	43.1	1861	2180	34.9	2
10	45.0	1861	2180	34.9	2
11	46.7	1861	2180	34.9	2
12	48.3	1861	2180	34.9	2
13	49.7	1861	2180	34.9	2
14	51.1	1861	2180	34.9	2
15	52.3	1861	2180	34.9	2
16	53.4	1861	2180	34.9	2
17	54.5	1861	2180	34.9	2
18	55.4	1861	2180	34.9	2
19	56.3	1861	2180	34.9	2
20	57.1	1861	2180	34.9	2
21	57.9	1861	2180	34.9	2
22	58.6	1861	2180	34.9	2

**Table 3.3-23 Relationship between Antenna Beam Number and Parameters  
for ScanSAR nominal [14MHz] Mode (Single/Dual Polarization)**

Scan Mode	Scan No. (Beam No.)	Off-nadir Angle [deg.]	Nominal PRF [Hz]	Max PRF [Hz]	Sampling Frequency [Hz]	No. of Bytes per Pixel [byte]
1	1	9.0	1249	1860	17.5	2
	2	15.0	1249	1860	17.5	2
	3	20.7	1249	1860	17.5	2
	4	25.9	1249	1860	17.5	2
	5	30.6	1249	1860	17.5	2
2	1	20.7	1249	1860	17.5	2
	2	25.9	1249	1860	17.5	2
	3	30.6	1249	1860	17.5	2
	4	34.8	1249	1860	17.5	2
	5	38.5	1249	1860	17.5	2
3	1	41.8	1249	1860	17.5	2
	2	44.7	1249	1860	17.5	2
	3	47.2	1249	1860	17.5	2
	4	49.5	1249	1860	17.5	2
	5	51.5	1249	1860	17.5	2
4	1	53.2	1249	1860	17.5	2
	2	54.7	1249	1860	17.5	2
	3	56.1	1249	1860	17.5	2
	4	57.3	1249	1860	17.5	2
	5	58.3	1249	1860	17.5	2

**Table 3.3-24 Relationship between Antenna Beam Number and Parameters  
for ScanSAR nominal [28MHz] Mode (Single/Dual Polarization)**

Scan Mode	Scan No. (Beam No.)	Off-nadir Angle [deg.]	Nominal PRF [Hz]	Max PRF [Hz]	Sampling Frequency [Hz]	No. of Bytes per Pixel [byte]
1	1	9.0	1249	1860	34.9	2
	2	15.0	1249	1860	34.9	2
	3	20.7	1249	1860	34.9	2
	4	25.9	1249	1860	34.9	2
	5	30.6	1249	1860	34.9	2
2	1	20.7	1249	1860	34.9	2
	2	25.9	1249	1860	34.9	2
	3	30.6	1249	1860	34.9	2
	4	34.8	1249	1860	34.9	2
	5	38.5	1249	1860	34.9	2
3	1	41.8	1249	1860	34.9	2
	2	44.7	1249	1860	34.9	2
	3	47.2	1249	1860	34.9	2
	4	49.5	1249	1860	34.9	2
	5	51.5	1249	1860	34.9	2
4	1	53.2	1249	1860	34.9	2
	2	54.7	1249	1860	34.9	2
	3	56.1	1249	1860	34.9	2
	4	57.3	1249	1860	34.9	2
	5	58.3	1249	1860	34.9	2

**Table 3.3-25 Relationship between Antenna Beam Number and Parameters  
for ScanSAR wide Mode (Single/Dual Polarization)**

Scan Mode	Scan No. (Beam No.)	Off-nadir Angle [deg.]	Nominal PRF [Hz]	Max PRF [Hz]	Sampling Frequency [Hz]	No. of Bytes per Pixel [byte]
1	1	9.1	1249	1860	17.5	2
	2	15.1	1249	1860	17.5	2
	3	20.7	1249	1860	17.5	2
	4	26.2	1249	1860	17.5	2
	5	30.8	1249	1860	17.5	2
	6	34.9	1249	1860	17.5	2
	7	38.6	1249	1860	17.5	2
2	1	34.9	1249	1860	17.5	2
	2	38.6	1249	1860	17.5	2
	3	41.8	1249	1860	17.5	2
	4	44.7	1249	1860	17.5	2
	5	47.3	1249	1860	17.5	2
	6	49.5	1249	1860	17.5	2
	7	51.5	1249	1860	17.5	2
3	1	49.5	1249	1860	17.5	2
	2	51.5	1249	1860	17.5	2
	3	53.2	1249	1860	17.5	2
	4	54.7	1249	1860	17.5	2
	5	56.1	1249	1860	17.5	2
	6	57.3	1249	1860	17.5	2
	7	58.3	1249	1860	17.5	2



**Table 3.3-26 Relationship between Antenna Beam Number and Parameters  
for High-sensitive Mode (Full (Quad.) Polarimetry)**

Beam No.	Off-nadir Angle [deg.]	Nominal PRF [Hz]	Max PRF [Hz]	Sampling Frequency [Hz]	No. of Bytes per Pixel [byte]
1	17.5	2392	3000	52.4	2
2	21.3	2392	3000	52.4	2
3	24.8	2392	3000	52.4	2
4	27.8	2392	3000	52.4	2
5	30.2	2392	3000	52.4	2
6	32.5	2392	3000	52.4	2
7	34.7	2392	3000	52.4	2

**Table 3.3-27 Relationship between Antenna Beam Number and Parameters  
for Fine Mode (Full (Quad.) Polarimetry)**

Beam No.	Off-nadir Angle [deg.]	Nominal PRF [Hz]	Max PRF [Hz]	Sampling Frequency [Hz]	No. of Bytes per Pixel [byte]
1	19.5	3623	3640	52.4	2

#### 4. Summary Information

The summary information on CEOS level 1.1/1.5/3.1 is shown in below.

##### 4.1. Outline of Summary Information

The summary information file includes the information for creating processed data created at ALOS-2 Data Processing System, and it is always made in a pair with its processed data.

##### 4.2. Filename of Summary Information

The filename of summary information is fixed as follows.

summary.txt

##### 4.3. File Format of Summary Information

The summary information file consists of some record lines which use LF (line feed code) as a termination, and does not include header information, footer information, etc. A record line consists of a keyword, an equal mark (=), and a value. A summary information file format outline is shown in Figure 4.3-1.

Keyword	=	Value	LF
...	...	...	...
Keyword	=	Value	LF

**Figure 4.3-1 Outline of Summary Information File Format**

##### 4.3.1. Format Definition of Keyword

- (1) The keyword is stored from the head of a record line.
- (2) The equal mark '=' is stored after the keyword.
- (3) There is no blank character between a keyword and '=', in principle.

##### 4.3.2. Format Definition of Value

- (1) The value is a text string bundled with double quotation letters (").
- (2) The value can contain alphabets, digits, and some special characters (except for double quotation). Numerical values are also stored as an ASCII string.
- (3) There is no blank character between '=' and the former double quotation letter, in principle.

##### 4.3.3. Contents of Summary Information

The items of the CEOS Level 1.1/1.5/3.1 summary information are described in Table 4.3-1. "b" in a table means blanks.

**Table 4.3-1 Summary information for CEOS Level 1.1/1.5/3.1 product (1/8)**

No.	Section	Item name	Keyword	Value
1	Ordering information (Odi)	Scene description ID	Odi_SceneId	ID for specifying a scene uniquely 'AAAAAAAAAAAAAAAAA-NNNNN-xxx-nnn' AAAAAAAAAAAAAAAAA: Operation Segment No NNNNN: Observation ID xxx: 001~999 nnn: Scene no.
2		Processed Site/Date/Time	Odi_SiteDateTime	Spacecraft Control Mission Operation system = 'PROCESS: JAPAN-JAXA-ALOS2-SCMObbYYYYMMDDbHHMMSS' Earth Intelligence Collection and Shearing System = 'PROCESS: JAPAN-JAXA-ALOS2-EICSbbYYYYMMDDbHHMMSS' YYYYMMDD : Processed date (YYYY: year, MM: month, DD: day) HHMMSS : Processed time (UTC)
3	Scene specification (Scs)	Scene ID	Scs_SceneID	'AAAAABBBBBCCCC-YYMMDD' AAAAA : Satellite name (= 'ALOS2') BBBBB : Orbit accumulation number of a scene center CCCC : Scene frame number of a scene center - : separator (hyphen) YYMMDD: Observation date of scene center
4		Amount of scene shift	Scs_SceneShift	'-5'~'4' : Except ScanSAR mode '-25'~'20' : ScanSAR mode Zero and positive number have no sign.

**Table 4.3-1 Summary information for CEOS Level 1.1/1.5/3.1 product (2/8)**

No.	Section	Item name	Keyword	Value
5	Product specification (Pds)	Product ID	Pds_ProductID	'DDDEFFFGHI' DDD: Observation mode SBS: Spotlight mode UBS: Ultra-fine mode (Single pol.) UBD: Ultra-fine mode (Dual pol.) HBS: High-sensitive mode (Single pol.) HBD: High-sensitive mode (Dual pol.) HBQ: High-sensitive mode (Full (Quad.) pol.) FBS: Fine mode (Single pol.) FBD: Fine mode (Dual pol.) FBQ: Fine mode (Full (Quad.) pol.) WBS: ScanSAR nominal [14MHz] mode (Single pol.) WBD: ScanSAR nominal [14MHz] mode (Dual pol.) WWS: ScanSR nominal [28MHz] mode (Single pol.) WWD: ScanSAR nominal [28MHz] mode (Dual pol.) VBS: ScanSAR wide mode (Single pol.) VBD: ScanSAR wide mode (Dual pol.) E : Observation direction L: Left looking, R: Right looking FFF: Processing level 1.0: Level 1.0, 1.1: Level 1.1, 1.5: Level 1.5, 3.1: Level 3.1 G : Processing option G: Geo-Coded, R: Geo-Reference, _ : n/a (underscore) H : Map projection type U: UTM, P: PS, M: MER, L: LCC, _ :n/a (underscore) I : Orbit direction A: Ascending, D: Descending

**Table 4.3-1 Summary information for CEOS Level 1.1/1.5/3.1 product (3/8)**

No.	Section	Item name	Keyword	Value
6	Product specification (Pds)	Resampling method	Pds_ResamplingMethod	'NN' / 'BL' / 'CC' (specify only for level 1.5/3.1 product) Nearest Neighbor / Bi-Linear / Cubic Convolution
7		UTM zone no.	Pds_UTM_ZoneNo	'1'~'60' (specify only for level 1.5/3.1 UTM projected product)
8		PS reference latitude	Pds_PS_ReferenceLatitude	Northern Hemisphere: '90.000', Southern Hemisphere: '-90.000' (specify only for level 1.5/3.1 PS projected product)
9		PS reference longitude	Pds_PS_ReferenceLongitude	'-179.999' ≤ reference longitude ≤ '180.000' (specify only for level 1.5/3.1 PS projected product)
10		LCC reference latitudinal line 1	Pds_LCC_ReferenceLatitudinalLine1	'-90.000' < reference latitude < '90.000' (specify only for level 1.5/3.1 LCC projected product)
11		LCC reference latitudinal line 2	Pds_LCC_ReferenceLatitudinalLine2	'-90.000' < reference latitude < '90.000' (specify only for level 1.5/3.1 LCC projected product)
12		Map direction	Pds_MapDirection	'MapNorth' (specify only for level 1.5/3.1 geocoded product)
13		LCC origin latitude	Pds_LCC_OriginLatitude	'-90.000' ≤ origin latitude ≤ '90.000' (specify only for level 1.5/3.1 LCC projected product)
14		LCC origin longitude	Pds_LCC_OriginLongitude	'-179.999' ≤ origin longitude ≤ '180.000' (specify only for level 1.5/3.1 LCC projected product)

A

**Table 4.3-1 Summary information for CEOS Level 1.1/1.5/3.1 product (4/8)**

No.	Section	Item name	Keyword	Value
15	Product specification (Pds)	Pixel spacing	Pds_PixelSpacing	unit: m (specify only for level 1.5/3.1 product)
16		Precision of orbit data	Pds_OrbitDataPrecision	'Precision' / 'Onboard' / 'RARR_Predict' Precision : High precision orbit information Onboard : Onboard orbit determination RARR_Predict : Predicted orbit information
17		Precision of attitude data	Pds_AttitudeDataPrecision	'Onboard' Onboard : Onboard attitude determination
18	Image information (Img)	Date and time of scene center	Img_SceneCenterDateTime	'YYYYMMDDbh: mm: ss.ttt'(UT) YYYY : Year (A.D.)
19		Date and time of scene start	Img_SceneStartDateTime	MM : Month (01~12) DD : Day (01~31)
20		Date and time of scene end	Img_SceneEndDateTime	hh : Hour (00~23) mm : Minute (00~59) ss : Second (00~60) (ss=60 is used only by a leap second.) ttt : Milli-second (000~999)
21		Latitude of image scene center	Img_ImageSceneCenterLatitude	'-90.000'~'90.000' [degree] (specify only for level 1.5/3.1 product) Third decimal places are not omissible. Zero and positive number have no sign.
22		Longitude of image scene center	Img_ImageSceneCenterLongitude	'-179.999'~'180.000' [degree] (specify only for level 1.5/3.1 product) Third decimal places are not omissible. Zero and positive number have no sign.
23		Latitude of image scene Left-Top	Img_ImageSceneLeftTopLatitude	'-90.000'~'90.000' [degree] (specify only for level 1.5/3.1 product) Third decimal places are not omissible. Zero and positive number have no sign.
24		Longitude of image scene Left-Top	Img_ImageSceneLeftTopLongitude	'-179.999'~'180.000' [degree] (specify only for level 1.5/3.1 product) Third decimal places are not omissible. Zero and positive number have no sign.
25		Latitude of image scene Right-Top	Img_ImageSceneRightTopLatitude	'-90.000'~'90.000' [degree] (specify only for level 1.5/3.1 product) Third decimal places are not omissible. Zero and positive number have no sign.
26	Longitude of image scene Right-Top	Img_ImageSceneRightTopLongitude	'-179.999'~'180.000' [degree] (specify only for level 1.5/3.1 product) Third decimal places are not omissible. Zero and positive number have no sign.	
27	Latitude of image scene Left-Bottom	Img_ImageSceneLeftBottomLatitude	'-90.000'~'90.000' [degree] (specify only for level 1.5/3.1 product) Third decimal places are not omissible. Zero and positive number have no sign.	

**Table 4.3-1 Summary information for CEOS Level 1.1/1.5/3.1 product (5/8)**

No.	Section	Item name	Keyword	Value
28	Image information (Img)	Longitude of image scene Left-Bottom	Img_ImageSceneLeftBottomLongitude	'-179.999'~'180.000' [degree] (specify only for level 1.5/3.1 product) Third decimal places are not omissible. Zero and positive number have no sign.
29		Latitude of image scene Right-Bottom	Img_ImageSceneRightBottomLatitude	'-90.000'~'90.000' [degree] (specify only for level 1.5/3.1 product) Third decimal places are not omissible. Zero and positive number have no sign.
30		Longitude of image scene Right-Bottom	Img_ImageSceneRightBottomLongitude	'-179.999'~'180.000' [degree] (specify only for level 1.5/3.1 product) Third decimal places are not omissible. Zero and positive number have no sign.
31		Latitude of frame scene center	Img_FrameSceneCenterLatitude	'-90.000'~'90.000' [degree] (specify only for level 1.5/3.1 product) Third decimal places are not omissible. Zero and positive number have no sign.
32		Longitude of frame scene center	Img_FrameSceneCenterLongitude	'-179.999'~'180.000' [degree] (specify only for level 1.5/3.1 product) Third decimal places are not omissible. Zero and positive number have no sign.
33		Latitude of frame scene Left-Top	Img_FrameSceneLeftTopLatitude	'-90.000'~'90.000' [degree] (specify only for level 1.5/3.1 product) Third decimal places are not omissible. Zero and positive number have no sign.
34		Longitude of frame scene Left-Top	Img_FrameSceneLeftTopLongitude	'-179.999'~'180.000' [degree] (specify only for level 1.5/3.1 product) Third decimal places are not omissible. Zero and positive number have no sign.
35		Latitude of frame scene Right-Top	Img_FrameSceneRightTopLatitude	'-90.000'~'90.000' [degree] (specify only for level 1.5/3.1 product) Third decimal places are not omissible. Zero and positive number have no sign.
36		Longitude of frame scene Right-Top	Img_FrameSceneRightTopLongitude	'-179.999'~'180.000' [degree] (specify only for level 1.5/3.1 product) Third decimal places are not omissible. Zero and positive number have no sign.
37		Latitude of frame scene Left-Bottom	Img_FrameSceneLeftBottomLatitude	'-90.000'~'90.000' [degree] (specify only for level 1.5/3.1 product) Third decimal places are not omissible. Zero and positive number have no sign.
38		Longitude of frame scene Left-Bottom	Img_FrameSceneLeftBottomLongitude	'-179.999'~'180.000' [degree] (specify only for level 1.5/3.1 product) Third decimal places are not omissible. Zero and positive number have no sign.
39		Latitude of frame scene Right-Bottom	Img_FrameSceneRightBottomLatitude	'-90.000'~'90.000' [degree] (specify only for level 1.5/3.1 product) Third decimal places are not omissible. Zero and positive number have no sign.
40		Longitude of frame scene Right-Bottom	Img_FrameSceneRightBottomLongitude	'-179.999'~'180.000' [degree] (specify only for level 1.5/3.1 product) Third decimal places are not omissible. Zero and positive number have no sign.
41			Off-nadir angle	Img_OffNadirAngle

**Table 4.3-1 Summary information for CEOS Level 1.1/1.5/3.1 product (6/8)**

No.	Section	Item name	Keyword	Value
42	Product information (Pdi)	Data size of product	Pdi_ProductDataSize	unit: Mbyte = 1024Kbyte Rounded off by the 2nd place of a decimal point. The first place of a decimal is not omissible.
43		Number of files in level 1.1/1.5/3.1 product	Pdi_CntOfL11ProductFileName Pdi_CntOfL15ProductFileName Pdi_CntOfL31ProductFileName	Spotlight mode: 4 files High-sensitive/Fine modes (Single pol.) : 4 files High-sensitive/Fine modes (Dual pol.) : 5 files ScanSAR mode (Single pol.): 4 files ScanSAR mode (Dual pol.): 5 files High-sensitive/Fine modes (Full (Quad.) pol.): 7 files * Level 1.1 ScanSAR mode product: ScanSAR nominal mode (Single pol.) : 8 files ScanSAR wide mode (Single pol.) : 10 files ScanSAR nominal mode (Dual pol.) : 13 files ScanSAR wide mode (Dual pol.) : 17 files
44		Filename of level 1.1/1.5/3.1 product	Pdi_L11ProductFileNamenn Pdi_L15ProductFileNamenn Pdi_L31ProductFileNamenn nn: 01~99	Volume directory file 'VOL-SSSSSSSSSSSSSSSSSSSS-PPPPPPPPPP' Leader file 'LED-SSSSSSSSSSSSSSSSSSSS-PPPPPPPPPP' Image file 'IMG-XX-SSSSSSSSSSSSSSSSSSSS-PPPPPPPPPP' Image file (Level 1.1 wide mode product) 'IMG-XX-SSSSSSSSSSSSSSSSSSSS-PPPPPPPPPP-YZ' Trailer file 'TRL-SSSSSSSSSSSSSSSSSSSS-PPPPPPPPPP' SSSSSSSSSSSSSSSSSSSS : Scene ID PPPPPPPPPP : Product ID XX : Polarization (HH, HV, VH, VV) (in order of Tx-Rx) Y : Processing mode(F: Full aperture, B: Burst) Z : Scan number (1-7)
45		Bits per pixel	Pdi_BitPixel	'NN' 16: Level 1.5/3.1 (specify only for level 1.5/3.1 product)

A

A

A



**Table 4.3-1 Summary information for CEOS Level 1.1/1.5/3.1 product (7/8)**

No.	Section	Item name	Keyword	Value
46	Product information (Pdi)	Number of pixels	Pdi_NoOfPixels_N N: Scan no. ( '1-7' for Level 1.1 Wide mode product, '0' for others)	'0' - '99999' (Zero-suppressible) The number of pixels of the SAR signal data in signal data record (prefix is not included).
47		Number of lines	Pdi_NoOfLines_N N: Scan no. ( '1-7' for Level 1.1 Wide mode product, '0' for others)	'0' - '99999' (Zero-suppressible) The number of lines of the SAR signal data in signal data record (file descriptor is not included).
48		Product format	Pdi_ProductFormat	'CEOS' (fixed value)
49	Result of auto check (Ach)	Checking result of Time data	Ach_TimeCheck	'GOOD' / 'POOR' GOOD: All lines are GPS-aligned, POOR: other than GOOD
50		Checking result of attitude data	Ach_AttitudeCheck	'GOOD' / 'POOR' GOOD: other than POOR. POOR: There are two or more lines which the posture and the rate are not converging.
51		Status of absolute navigation	Ach_AbsoluteNavigationStatus	blank
52		Checking result of house keeping data	Ach_HouseKeepingDataCheck	'GOOD' / 'FAIR' FAIR: There are one or more FAIR(s) among check items.
53		Checking result of orbit data	Ach_OrbitCheck	'GOOD' / 'FAIR' GOOD: All values are normal. FAIR: All abnormal values are interpolated correctly.
54		Checking result of on-board attitude data	Ach_OnBoardAttitudeCheck	'GOOD' / 'FAIR' GOOD: All values are normal. FAIR: All abnormal values are interpolated correctly.
55		Loss lines	Ach_LossLines	'GOOD' / 'FAIR' / 'POOR' GOOD: There is no loss line. FAIR: Number of loss line is 1 or more, but is not more than threshold value. POOR: Number of loss line is more than threshold value.
56		Absolute navigation time	Ach_AbsoluteNavigationTime	blank
57		Checking result of PRF change	Ach_PRF_Check	blank

**Table 4.3-1 Summary information for CEOS Level 1.1/1.5/3.1 product (8/8)**

No.	Section	Item name	Keyword	Value
58	Result of auto check (Ach)	Checking result of calibration data	Ach_CalibrationDataCheck	blank
59	Result information (Rad)	Practice result code	Rad_PracticeResultCode	'GOOD' / 'FAIR' GOOD: normal FAIR: A product can be created by interpolating
60	Label information (Lbi)	Satellite name	Lbi_Satellite	'ALOS2' (fixed value)
61		Sensor name	Lbi_Sensor	'SAR' (fixed value)
62		Processing level	Lbi_ProcessLevel	'1.0' / '1.1' / '1.5' / '3.1'
63		Processing facility	Lbi_ProcessFacility	'SCMO' / 'EICS' SCMO : Spacecraft Control Mission Operation system EICS : Earth Intelligence Collection and Shearing System
64		Observation date	Lbi_ObservationDate	'YYYYMMDD' YYYYMMDD : (YYYY: year, MM: month, DD: day)

## 5. Appendix

### 5.1. Thumbnail Image

A thumbnail image is generated by transforming a processed data type to 8 bit integer and by averaging pixels to be 50, 100 or 500m spacing (spotlight, High resolution[UB, HB, FB] and ScanSAR modes, respectively), in the level 1.1/1.5/3.1 processing. The number of thumbnail images of multi-polarization modes (dual pol., compact pol. and full (quad.) pol.) is equal to the number of polarizations, and that of level 1.1 of ScanSAR mode is equal to the number of polarizations multiplied by scans.

The image format is JPEG or PDF. The thumbnail image format is shown in Table 5.1-1.

**Table 5.1-1 Thumbnail Image Format**

Item	Definition
File Name (ScanSAR level 1.1)	JPEG file : BRS-polarization-scene ID-product ID-scan.jpg PDF file : BRS-polarization-scene ID-product ID-scan.pdf
File Name (except ScanSAR level 1.1)	JPEG file : BRS-polarization-scene ID-product ID.jpg PDF file : BRS-polarization-scene ID-product ID.pdf
Data Type	8 bit Integer
Record Length	Variable
Record Number	Variable
Image Frame	Same as Image File
Pixel Spacing	50m : Spotlight Mode 100m : High Resolution Mode 500m : ScanSAR Mode
Map Projection	Same as Image File

## 5.2. Image File of ScanSAR Level 1.1 Product

### 5.2.1. Processing Mode and Data Storage Outline of ScanSAR Level 1.1 Product

A level 1.1 product of ScanSAR mode is generated by “Full-Aperture method” or “SPECAN method”.

#### < Full-Aperture Method >

In each scan and polarization, the gaps between bursts in a sub swath are filled with zeros and range and azimuth compressions are performed. An image file per each scan and polarization is generated (see Figure 5.2-1 and Figure 5.2-2).

| A

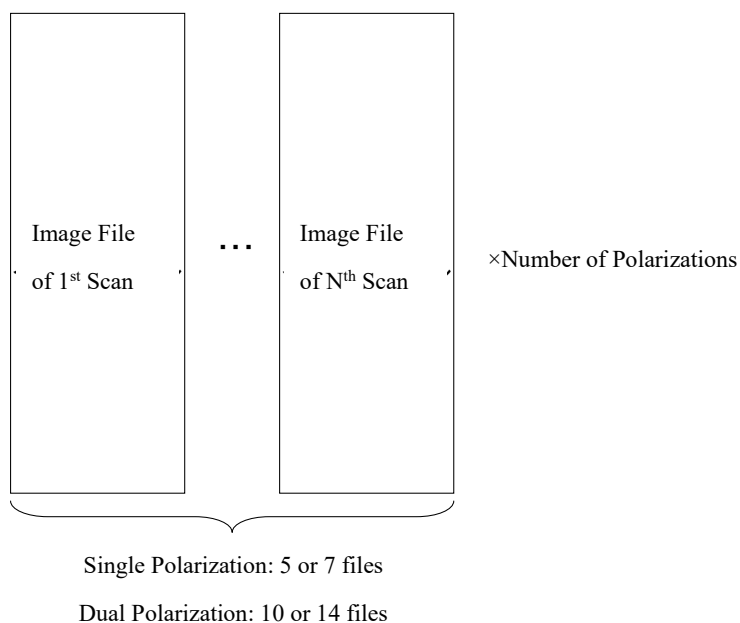

**Figure 5.2-1 Level 1.1 Image File of ScanSAR Mode (Full-Aperture Method)**

| A

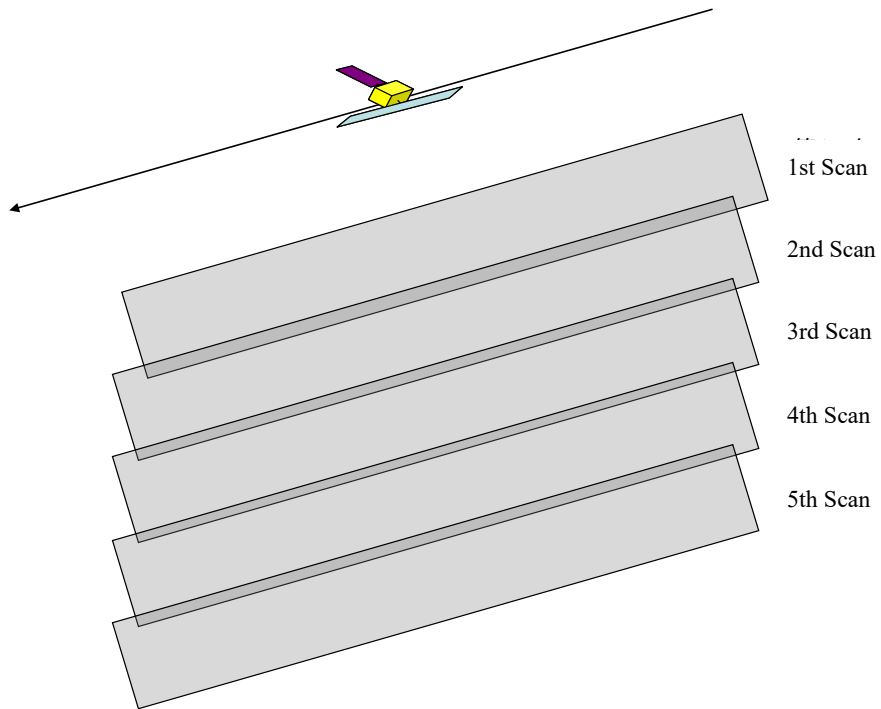

**Figure 5.2-2 Relationship between Level 1.1 Image Files of ScanSAR Mode and Observed Areas (Full-Aperture Method) (5 scans)**

| A

< SPECAN Method >

Range and azimuth compressions are performed per each burst.

Burst data of a sub swath is stored in a same image file sequentially. In the case of the SPECAN method, an image file per each scan and polarization is generated.

Successive burst images are overlapped (Figure 5.2-4 represents the relationship between Level 1.1 image file of ScanSAR mode and observed area). A

Images of successive burst data are represented in Figure 5.2-5. The image of a ground target is included in successive bursts, as shown in Figure 5.2-4 and Figure 5.2-5.

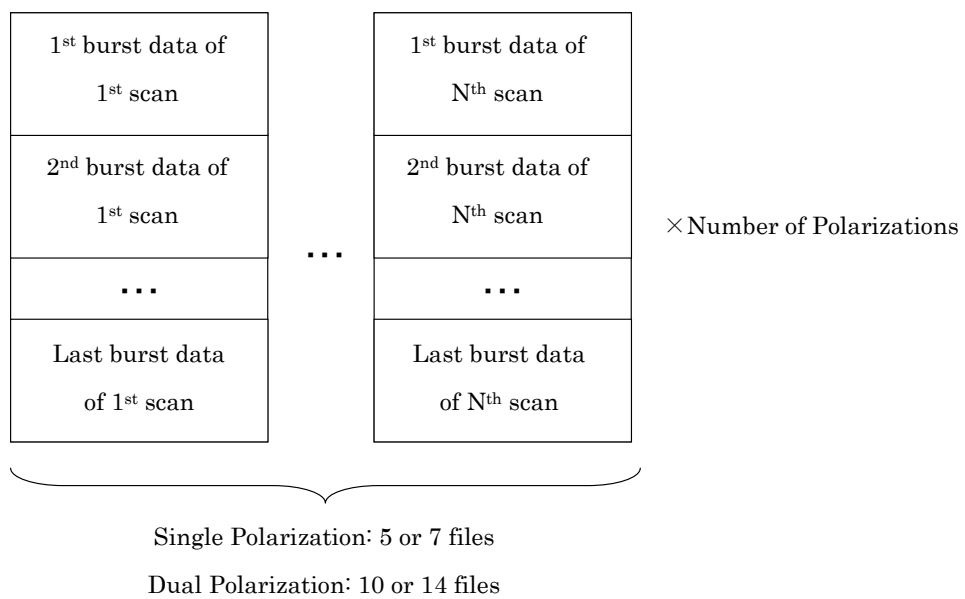

**Figure 5.2-3 Level 1.1 Image File of ScanSAR Mode (SPECAN method)**

A

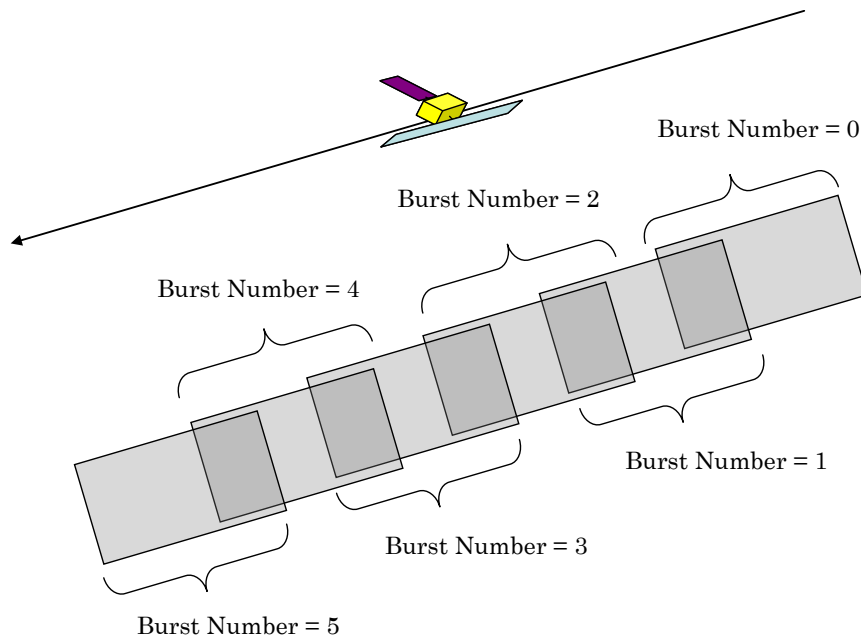

**Figure 5.2-4 Relationship between Level 1.1 Image Files of ScanSAR Mode and Observed Area (SPECAN method) (1 scan)**

|A

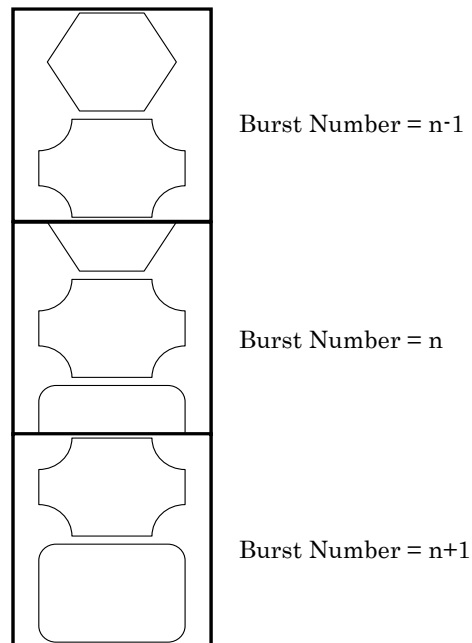

**Figure 5.2-5 Images of Successive Burst Data in a CEOS Image File**

|A

### 5.2.2. Acquisition of Parameters from Image File in SPECAN method

This section describes about the parameter acquisition to extract a burst data from the level 1.1 image file generated by the burst algorithm.

< Acquisition of Parameters from SAR Image File Descriptor Record (see also Table 5.2-1)>

- (1) Read the value of “Byte No 187-192 SAR data record length”.

This value means the byte number of each signal data record and is defined as “BytePerLine”.

- (2) Read the value of “Byte No 249-256 Number of data group (or pixels) per line”.

This value means the number of pixels of each signal data record and is defined as “NPixel”.

In the case of the level 1.1, the byte number per pixel is 8 and there are no zero padding data outside of valid pixels. Therefore,  $\text{BytePerLine} = 8 * \text{NPixel}$ .

- (3) Read the value of “Byte No 449-452 Number of burst data in this file”

This value means the number of burst data in an image file and is defined as “NBurst”.

- (4) Read the value of “Byte No 453-456 Number of lines per one burst”

This value means the number of lines in a burst data and is defined as “NLinePerBurst”.

- (5) Read the value of “Byte No 457-460 Number of overlap lines with adjacent bursts”

This value means the number of overlap lines between adjacent bursts and is defined as “NOverlapLine”.

In the case of  $\text{NLinePerBurst} = 300$  and  $\text{NOverlapLine} = 100$ , the signal data corresponding to the area overlapped by one third in between adjacent bursts are stored in the signal data record.



**Table 5.2-1 SAR Image File Descriptor Record (Show necessary part only)**

Field No.	Byte No.	Type	Description (Definition and Value)	Remark
omission				
30	187 - 192	16	SAR DATA record length	
omission				
39	249 - 256	18	Total number of data groups (or pixels) per line per SAR channel	For a level 1.1 product, each data record corresponds to 1 image range line. Each range line begins at the nearest-range pixel and ends at the farthest-range pixel.
omission				
66	449 - 452	14	In the case of the level 1.1 of ScanSAR mode and the SPECAN method: The number of burst data in a SAR Image file (from one).  In other cases: blank	In the case of ScanSAR level 1.1 and SPECAN method, set the number of burst data in a SAR Image file. In other cases, set blank (0).
67	453 – 456	14	In the case of the level 1.1 of ScanSAR mode and the SPECAN method: The number of lines per burst data (from one) In other cases: blank	In the case of ScanSAR level 1.1 and SPECAN method, set the number of lines per burst data (the number of lines does not change dependent on bursts) In other cases, set blank (0).
68	457 – 460	14	In the case of the level 1.1 of ScanSAR mode and the SPECAN method: The number of overlapped lines between adjacent bursts (from zero) In other cases: blank	In the case of ScanSAR level 1.1 and SPECAN method, set the number of overlapped lines between adjacent bursts. In the case of no overlapping, set 0. In other cases, set blank (0).
omission				

< Acquisition of Parameters from Signal Data Record (see also Table 5.2-2)>

(1) Read the value of “Byte No 217-220 Burst number”

This value means the sequential number for each burst data in an image file (0 – Nburst-1) and is defined as “BurstNo”.

(2) Read the value of “Byte No 221-224 Line number in this burst”

This value means the sequential number for each line in a burst (0 – NlinePerBurst-1) and is defined as “LineNoInBurst”.

**Table 5.2-2 Signal Data Record (Show necessary part only)**

Field No.	Byte No.	Type	Description (Definition and Value)	Remark
omission				
57	217 – 220	B4	In the case of ScanSAR level 1.1: Burst number = 0) <sub>10</sub> ~ Except ScanSAR level 1.1: Blank = 0) <sub>10</sub>	In the case of ScanSAR level 1.1 and SPECAN method, define the first burst number as zero. In other cases, set blank (0).
58	221 – 224	B4	In the case of ScanSAR level 1.1: Line number in this burst = 0) <sub>10</sub> ~ Except ScanSAR level 1.1: Blank = 0) <sub>10</sub>	In the case of ScanSAR level 1.1 and SPECAN method, set numbers sequentially from zero. In other cases, set blank (0).
omission				

Table 5.2-3 shows total line number, burst number and line number in a burst.

**Table 5.2-3 Total Line Number, Burst Number and Line Number in a Burst**

Total Line Number (LineNo)	Burst Number (BurstNo)	Line Number in a Burst (LineNoInBurst)
1	0	0
2	0	1
...	0	...
NLinePerBurst	0	NLinePerBurst-1
NLinePerBurst+1	1	0
NLinePerBurst+2	1	1
...	1	...
2 * NLinePerBurst	1	NLinePerBurst-1
(2 * NLinePerBurst) + 1	2	0
(2 * NLinePerBurst) + 2	2	1
...	2	...
3 * NLinePerBurst	2	NLinePerBurst-1
...	...	...

### 5.3. Low Resolution Image Data Record

A low resolution image data in a trailer file is generated by transforming a processed data type to 8 bit integer and by averaging pixels to be 50, 100 or 500m spacing (spotlight, High resolution[UB, HB, FB] and ScanSAR modes, respectively), in the level 1.1/1.5/3.1 processing.

A trailer file stores the image of HH or VV polarization in the case of the dual polarization mode and stores the image of HH polarization in the case of the polarimetry mode. The format of the low resolution image data is shown in Table 5.3-1.

**Table 5.3-1 Format of Low Resolution Image Data**

Item	Specification
Data Type	16 bit integer
Record Length	Variable
Number of Records	Variable
Image Frame	Same as SAR Image file
Pixel Spacing	50m : Spotlight Mode 100m : High Resolution Mode 500m : ScanSAR Mode
Map Projection	Same as SAR Image file



**PALSAR-2**

**Level 2.1 CEOS SAR Product**

**Format Description**

**Japan Aerospace Exploration Agency**

ALOS-2 Product Format Description  
CEOS Level 2.1 Revision History (1/6)

Rev.	Date	Revision Contents	Remark
NC	2012/12/28	First Edition	
A	2014/5/16	<p>p.17, p.20, p.56 Removed the statement about predicted ephemeris. Before: Predicted ephemeris After: Dummy data Corresponding sections are as follows:</p> <ul style="list-style-type: none"> <li>• p.17 Table3-2 Record Structure of CEOS level 2.1 Format</li> <li>• p.20 Table 3-5 Facility Related Data Record Type</li> <li>• p.56 Table 3 16 Facility related data records 1 - 4 (1/1) Field No.1, 6, 9</li> </ul>	
		<p>p.22, p29, p.61, p69 Revised 'software release and revision level' from NN.NN to NNN.NNN. Before: Software release and revision level = 'NN.NNbbbbbb' 1.00, 1.01, ... 1.10, ... 2.00 After: Software release and revision level = 'NNN.NNNbbbbbb' 001.000, 001.001, ... 001.100, ...002.000 Corresponding sections are as follows:</p> <ul style="list-style-type: none"> <li>• p.22 Table 3-6 Volume descriptor records (1/2) Field No.12</li> <li>• p.29 Table 3-9 SAR Leader file descriptor records (1/3) Field No.12</li> <li>• p.61 Table 3-18 SAR Image file descriptor records (1/4) Field No.12</li> <li>• p.69 Table 3-20 SAR Trailer file descriptor (1/3) Field No.12</li> </ul>	

ALOS-2 Product Format Description  
CEOS Level 2.1 Revision History (2/6)

Rev.	Date	Revision Contents	Remark
A cont.		<p>P34 Table 3-10 Field No.34 Added suffix: "mode." Before: '01': Ultra-fine '02': High-sensitive '03': Fine '18': Full (Quad.) pol./High-sensitive '19': Full (Quad.) pol./Fine After: '01': Ultra-fine mode '02': High-sensitive mode '03': Fine mode '18': Full (Quad.) pol./High-sensitive mode '19': Full (Quad.) pol./Fine mode</p>	
		<p>p.37 Table 3-10 Data set summary records (6/12) Added description of 'Processing version ID' (Field No.82) due to revise of software release &amp; revision number format. Before: Processing version ID After: Processing version ID='NNN.NNNb'</p>	

ALOS-2 Product Format Description  
CEOS Level 2.1 Revision History (3/6)

Rev.	Date	Revision Contents	Remark
A cont.		<p>p.38 Table 3-10 Data set summary records (7/12) Revised description as follows. [Field No.96] Before: Resolution in ground range [m] = Nominal value After: Resolution in ground range [m] = Nominal value * number of looks in range direction [Field No.97] Before: Resolution in azimuth [m] = Nominal value After: Resolution in azimuth [m] = Nominal value * number of looks in azimuth direction [Field No.102] Before: Along track Doppler frequency (center) quadratic coefficient terms at early edge of image [Hz/pixel/pixel] = Value After: Along track Doppler frequency (center) quadratic coefficient terms at early edge of image [Hz/pixel/pixel] = Blanks</p>	
		<p>p.57 Table 3-17 Facility related data records (1/4) Erased the following description of ‘Twenty coefficients to convert from the map projection (E, N) to Line (L) and pixel (P) position in the image’, Level 1.5/3.1: Level 1.1: Blanks</p>	



ALOS-2 Product Format Description  
CEOS Level 2.1 Revision History (4/6)

Rev.	Date	Revision Contents	Remark
A cont.		<p>p.62 Table 3-18 SAR Image file descriptor records (2/4) Revised remarks as follows. [Field No.28] Before: Number of actual records After: Copy the value of Level 1.1 [Field No.29] Before: Actual record length After: Number of actual records [Field No.30] Before: (Blank) After: Actual record length</p>	
		<p>p.77 Table 4-1 Summary information for CEOS Level 2.1 product (3/8) Corrected misdescription. Before: GSIGEO2000: Japanese Geoid Model (Geographical Survey Institute) After: GSIGEO2000: Japanese Geoid Model (Geospatial Information Authority of Japan)</p>	
		<p>p.80 Table 4-1 Summary information for CEOS Level 2.1 product (6/8) Revised description of 'Data size of product'. Before: Mbytes = 1024Kbyte After: Mbyte = 1024Kbyte</p>	
		<p>p.80 Table 4-1 Summary information for CEOS Level 2.1 product (6/8) Erased the following description of 'Filename of level 2.1 product', Image file (Level 1.1 wide mode product) 'IMG-XX-SSSSSSSSSSSSSSSSSSSSSS-PPPPPPPPPP-YZ'</p>	

ALOS-2 Product Format Description  
CEOS Level 2.1 Revision History (5/6)

Rev.	Date	Revision Contents	Remark
A cont.		p.80 Table 4-1 Summary information for CEOS Level 2.1 product (6/8) Revised the value of 'Product format'. Before: 'CEOS'/'GeoTIFF' After: 'CEOS'	
		p.81 Table 4-1 Summary information for CEOS Level 2.1 product (7/8) Revised the value of 'Status of absolute navigation' Before: Blank After: 'OK'/'NG'	
		p.82 Table 4-1 Summary information for CEOS Level 2.1 product (8/8) Erased description of 'Copy the value of L1.1' written in remark of 'Processing facility'	
B	2015/2/10	P.25 Table 3-7 File pointer records (2/3) No.15 Correct the number of records. Before : Trailer file = N+1 (N is the number of low resolution image data records) After : Trailer file = 'bbbbbb2'	
		P.26 Table 3-7 File pointer records (3/3) No.23 Correct the number of records. Before : Trailer file = N+1 (N is the number of low resolution image data records) After : Trailer file = 'bbbbbb2'	
		P.38 Table 3-10 Data set summary records (7/12) No.100 Added description of ('= Blanks')	
		P.48 Table 3-12 Platform position data records (1/2) No.11-13 Correct the descriptions. Before : Position vector in the earth /// After : Velocity vector in the earth ///	

ALOS-2 Product Format Description  
CEOS Level 2.1 Revision History (6/6)

Rev.	Date	Revision Contents	Remark
C	2021/12/6	<p>p.44</p> <p>Table 3-11 Map projection data records (1/4)</p> <p>Correct the descriptions.</p> <p>Before: Map projection = 'GEOCODEDbbbbbbbbbbbbbbbbbbbb'</p> <p>After: Map projection = 'GEOCODEDbbbbbbbbbbbbbbbbbbbb'</p>	

ALOS-2 Product Format Description  
(CEOS Level 2.1 Format)

Table of Contents

1. Overview .....	1
2. Product Specifications .....	2
2.1. Definition of Processing Levels .....	2
2.2. Definition of Scene .....	3
2.2.1. Scene Size .....	3
2.2.2. Data Volume of Scene .....	4
2.3. Format .....	7
2.4. Product Description .....	7
2.5. Processing Parameter .....	9
2.6. Definition of Level 2.1 Image .....	12
2.7. Notes .....	12
3. Product Formats .....	13
3.1. Composition of CEOS Product .....	13
3.2. Record Structure of CEOS Product .....	17
3.2.1. Record Data Type .....	18
3.2.2. Record Type Code and Record Sub-type Code .....	18
3.3. Contents of Records in CEOS Files .....	21
4. Summary Information .....	73
4.1. Outline of Summary Information .....	73
4.2. Filename of Summary Information .....	73
4.3. File Format of Summary Information .....	73
4.3.1. Format Definition of Keyword .....	73
4.3.2. Format Definition of Value .....	73
4.3.3. Contents of Summary Information .....	74

## 1. Overview

This document describes the CEOS (Committee on Earth Observation Satellites) SAR format specifications for ALOS-2 Level 2.1 products which are generated with the ALOS-2 Data Processing System. The formats are based on the CEOS SAR formats of the ALOS/PALSAR products to take user friendliness into account and added new items for ALOS-2.

## 2. Product Specifications

### 2.1. Definition of Processing Levels

The definition of processing levels of ALOS-2 products is shown in Table 2-1. This document describes the data formats for CEOS level 2.1 products.

**Table 2-1 Definition of Processing Levels**

Level	Definition	Remark
1.0	Data corresponding to a scene area is extracted from received data. Data type is 8 bit. In the case of multi-polarization modes, the number of SAR data files is equal to the number of polarizations. In the case of ScanSAR mode, the data file is not divided into each scan. In the case of ATI and compact polarimetry observations, only level 1.0 product is generated.	
1.1	Range and single look azimuth compressed data is represented by complex I and Q channels to preserve the magnitude and phase information. Range coordinate is in slant range. Level 1.1 image is focused onto zero Doppler direction. In the case of ScanSAR mode, an image file is generated per each scan.	SLC : Single Look Complex. Interferometry processing requires SLC data.
1.5	Range and multi-look azimuth compressed data is represented by amplitude data. Range coordinate is converted from slant range to ground range, and map projection is performed. Pixel spacing is selectable depending on observation modes. There are two methods to transform image coordinate; G : Image coordinate in map projection is geocoded. R : Image coordinate in map projection is georeferenced.	G or R is selectable.
2.1	Level 2.1 data is orthorectified from level 1.1 data by using digital elevation model. Pixel spacing is selectable depending on observation modes. Image coordinate in map projection is geocoded.	
3.1	Image quality corrections (noise reduction and dynamic range compression) are performed to level 1.5 data.	

## 2.2. Definition of Scene

### 2.2.1. Scene Size

Scene sizes for level 2.1 products of each observation mode are shown in Table 2-2 and Table 2-3.

**Table 2-2 Scene Size for Level 2.1 Products  
(Except Full (Quad.) Polarimetry)**

Observation Mode	Spotlight	Ultra-Fine	High-sensitive	Fine	ScanSAR nominal [28MHz]	ScanSAR nominal [14MHz]	ScanSAR wide [490km]
Length of Range Direction	25km	55km	55km	70km	350.5km	350.5km	489.5km
Length of Azimuth Direction	25km	70km	70km	70km	355km	355km	355km
Time Duration of Azimuth Direction	N/A	10sec	10sec	10sec	52sec	52sec	52sec
Range Resolution*	3.0m	3.0m	6.0m	9.1m	47.5m(5look)	95.1m(5look)	44.2m(2look)
Azimuth Resolution*	1.0m	3.0m	4.3m	5.3m	77.7m(3look)	77.7m(3look)	56.7m(1.5look)

\*: The values in Table 2-2 are defined as those in single look processing and at the incidence angle 37 deg (unless otherwise noted).

**Table 2-3 Scene Size for Level 2.1 Products (Full (Quad.) Polarimetry)**

Observation Mode	High-sensitive	Fine
Length of Range Direction	40-50km	30km
Length of Azimuth Direction	70km	70km
Time Duration of Azimuth Direction	10sec	10sec
Range Resolution*	5.1m	8.7m
Azimuth Resolution*	4.3m	5.3m

\*: The values in Table 2-3 are defined as those in single look processing and at the incidence angle 37 deg (unless otherwise noted).

### 2.2.2. Data Volume of Scene

The number of pixels, pixel spacing and data volumes for each observation mode are shown in Table 2-4 - Table 2-10.

**Table 2-4 Level 2.1 Image Size and Volume for Spotlight Mode**

Spotlight Mode				
Pixel Spacing	Image Size East-West x South-North	Number of Pixels and Data Volume		
		East-West	South-North	Volume [MB]
0.625m	25x25km	40,000~56,600	40,000~56,600	3,052~6,110
1.25m	25x25km	20,000~28,300	20,000~28,300	763~1,528
2.5m	25x25km	10,000~14,200	10,000~14,200	191~385

\*: 1MB = 2<sup>20</sup>Bytes

\*: Maximum data volume (not included the expanding by the differences of map projections.)

**Table 2-5 Level 2.1 Image size and Volume for Ultra-Fine Mode  
(Single Polarization)**

Ultra-Fine Mode				
Pixel Spacing	Image Size East-West x South-North	Number of Pixels and Data Volume		
		East-West	South-North	Volume [MB]
2.5m	55x70km	22,000~35,400	28,000~35,400	1,175~2,390
	52.5x70km	21,000~34,700	28,000~34,700	1,122~2,297
	50x70km	20,000~34,000	28,000~34,000	1,068~2,205
5m	55x70km	11,000~17,700	14,000~17,700	294~598
	52.5x70km	10,500~17,400	14,000~17,400	280~577
	50x70km	10,000~17,000	14,000~17,000	267~551
10m	55x70km	5,500~8,900	7,000~8,900	73~151
	52.5x70km	5,250~8,700	7,000~8,700	70~144
	50x70km	5,000~8,500	7,000~8,500	67~138

\*: 1MB = 2<sup>20</sup>Bytes

\*: Maximum data volume (not included the expanding by the differences of map projections.)

\*: In the case of dual polarization, the data volume is twice as that of a single polarization.



**Table 2-6 Level 2.1 Image size and Volume for High-sensitive Mode  
(Single Polarization)**

High-sensitive Mode				
Pixel Spacing	Image Size East-West x South-North	Number of Pixels and Data Volume		
		East-West	South-North	Volume [MB]
3.125m	55x70km	17,600~28,300	22,400~28,300	752~1,528
	52.5x70km	16,800~27,800	22,400~27,800	718~1,474
	50x70km	16,000~27,200	22,400~27,200	684~1,411
6.25m	55x70km	8,800~14,200	11,200~14,200	188~385
	52.5x70km	8,400~13,900	11,200~13,900	179~369
	50x70km	8,000~13,600	11,200~13,600	171~353
12.5m	55x70km	4,400~7,100	5,600~7,100	47~96
	52.5x70km	4,200~7,000	5,600~7,000	45~93
	50x70km	4,000~6,800	5,600~6,800	43~88

\*: 1MB = 2<sup>20</sup>Bytes

\*: Maximum data volume (not included the expanding by the differences of map projections.)

\*: In the case of dual polarization, the data volume is twice as that of a single polarization.

**Table 2-7 Level 2.1 Image size and Volume for Fine Mode (Single Polarization)**

Fine Mode				
Pixel Spacing	Image Size East-West x South-North	Number of Pixels and Data Volume		
		East-West	South-North	Volume [MB]
6.25m	70x70km	11,200~15,900	11,200~15,900	239~482
	65x70km	10,400~15,300	11,200~15,300	222~446
	60x70km	9,600~14,800	11,200~14,800	205~418
	55x70km	8,800~14,200	11,200~14,200	188~385
	50x70km	8,000~13,600	11,200~13,600	171~353
12.5m	70x70km	5,600~8,000	5,600~8,000	60~122
	65x70km	5,200~7,700	5,600~7,700	56~113
	60x70km	4,800~7,400	5,600~7,400	51~104
	55x70km	4,400~7,100	5,600~7,100	47~96
	50x70km	4,000~6,800	5,600~6,800	43~88

\*: 1MB = 2<sup>20</sup>Bytes

\*: Maximum data volume (not included the expanding by the differences of map projections.)

\*: In the case of dual polarization, the data volume is twice as that of a single polarization.

**Table 2-8 Level 2.1 Image size and Volume for ScanSAR Mode (Single Polarization)**

ScanSAR Mode				
Pixel Spacing	Image Size East-West x South-North	Number of Pixels and Data Volume		
		East-West	South-North	Volume [MB]
25m	350x350km	14,000~19,800	14,000~19,800	374~748
	490x350km	19,600~23,800	14,000~23,800	523~1,080
50m	350x350km	7,000~9,900	7,000~9,900	93~187
	490x350km	9,800~11,900	7,000~11,900	131~270
100m	350x350km	3,500~5,000	3,500~5,000	23~48
	490x350km	4,900~6,000	3,500~6,000	83~69

\*: 1MB = 2<sup>20</sup>Bytes

\*: Maximum data volume (not included the expanding by the differences of map projections.)

\*: In the case of dual polarization, the data volume is twice as that of a single polarization.

**Table 2-9 Level 2.1 Image size and Volume for High-sensitive Mode  
(Full (Quad.) Polarization)**

High-sensitive Mode (Full (Quad.) pol.)				
Pixel Spacing	Image Size East-West x South-North	Number of Pixels and Data Volume		
		East-West	South-North	Volume [MB]
3.125m	50x70km	16,000~27,200	22,400~27,200	2,734~5,645
6.25m	50x70km	8,000~13,600	11,200~13,600	684~1,411
12.5m	50x70km	4,000~6,800	5,600~6,800	171~353

\*: 1MB = 2<sup>20</sup>Bytes

\*: Maximum data volume (not included the expanding by the differences of map projections.)

\*: Total data volume for four polarizations

**Table 2-10 Level 2.1 Image size and Volume for Fine Mode  
(Full (Quad.) Polarization)**

Fine Mode (Full (Quad.) pol.)				
Pixel Spacing	Image Size East-West x South-North	Number of Pixels and Data Volume		
		East-West	South-North	Volume [MB]
6.25m	30x70km	4,800~11,400	11,200~11,400	410~992
12.5m	30x70km	2,400~5,700	5,600~5,700	103~248

\*: 1MB = 2<sup>20</sup>Bytes

\*: Maximum data volume (not included the expanding by the differences of map projections.)

\*: Total data volume for four polarizations

### 2.3. Format

ALOS-2 CEOS level 2.1 data is based on the CEOS superstructure formats and consists of following files: Volume Directory File, SAR Leader File, SAR Image File and SAR Trailer File.

### 2.4. Product Description

In the case of multi-polarization data (i.e. Dual pol. and Full (Quad.) pol. data), the image data of ALOS-2 CEOS level 2.1 is divided in each polarization.

The SAR Image file composition of CEOS level 2.1 for each observation mode is shown in Table 2-11.

**Table 2-11 SAR Image File Composition of CEOS Level 2.1 for Each Observation Mode**

Observation Mode	Polarization	Processing Level	Number of Data Files	Data File Composition
Spotlight	Single Pol. (HH, HV, VH or VV *1)	2.1	1	Data of HH, HV, VH or VV Polarization
Ultra-Fine, High-sensitive and Fine	Single Pol. (HH, HV, VH or VV)	2.1	1	Data of HH, HV, VH or VV Polarization
	Dual Pol. (HH+HV or VH+VV)	2.1	2	Data of HH+HV Polarization, or VH+VV Polarization
	Full Pol. (HH+HV+VH+VV)	2.1	4	Data of HH, HV, VH and VV Polarization
ScanSAR nominal and wide	Single Pol. (HH, HV, VH or VV)	2.1	1	Data of HH, HV, VH or VV Polarization
	Dual Pol. (HH+HV or VH+VV)	2.1	2	Data of HH+HV Polarization, or VH+VV Polarization

\*1 The order of transmitting, receiving polarization.

## 2.5. Processing Parameter

Table 2-12 shows the processing parameters of level 2.1.

**Table 2-12 Processing Parameter**

Parameter	Level 2.1
Map Projection	UTM, PS, MER(*4), LCC(*4) (refer to Table 2-13)
Framing	Geo-coded
Image Direction	Map
Resampling Method	NN, BL, CC
Geodetic coordinate	ITRF97
Ellipsoid	GRS80
Scene Shift	-5 to 4 (-25 to 20 *4)
Window Function	Rectangle
Number of Multi-look	Depending on observation mode and pixel spacing (refer to Table 2-14)
Pixel Spacing	Spotlight mode            0.625m/1.25m/2.5m Ultra-fine mode            2.5m/5.0m/10.0m High-sensitive mode        3.125m/6.25m/12.5m Fine mode                    6.25m/12.5m ScanSAR mode              25.0m/50.0m/100.0m (refer to Table 2-14)
Digital Elevation Model (DEM)	GISMAP Terrain (Hokkaido-Chizu Company Ltd.) (*1) SRTM 90m Digital Elevation Database v4.1 (CSI) (*2)
Geoid Model	GSIGEO2000 (Geospacial Information Authority of Japan) (*1) Earth Gravitational Model 1996 (EGM96) (National Geospacial-Intelligence Agency) (*3)

\*1 GISMAP Terrain is available in only Japan.

\*2 SRTM covers the regions within +/-60 degrees latitudes in the world.

\*3 EGM96 is available in the world.

\*4 In the case of ScanSAR mode, the values in the brackets are available.

**Table 2-13 Conditions for specifying Map Projection**

Map projection	Parameter	Condition	Default Value (not specified)
UTM		Range of scene center latitude: -83 ~ +83 deg.	
	UTM zone No.	Zone No. including scene center longitude +/- 4.	Zone No. including scene center longitude
PS		Range of scene center latitude: -83 ~ -25 deg. or +25 ~ +83 deg.	
	PS reference latitude	Scene center in the northern hemisphere: +25 ~ +90 deg. Scene center in the southern hemisphere: -90 ~ -25 deg.	Northern hemisphere: +90 deg. Southern hemisphere: -90 deg.
	PS reference longitude	Arbitrary (-179.999 ~ +180.000 deg.)	Scene center longitude
MER		Range of scene center latitude: -70 ~ +70 deg.	
LCC		Range of scene center latitude: -70 ~ +70 deg.	
	LCC standard parallel 1 $\phi_1$	Scene center in the northern hemisphere: $0 \leq \phi_2 < \phi_1 < +90$ deg. Scene center in the southern hemisphere:	Northern hemisphere: +50 deg. Southern hemisphere: -50 deg.
	LCC standard parallel 2 $\phi_2$	hemisphere: $-90 < \phi_1 < \phi_2 \leq 0$ deg.	Northern hemisphere: +20 deg. Southern hemisphere: -20 deg.
	LCC origin latitude	-90.000 ~ +90.000 deg.	0 deg.
	LCC origin longitude	-179.999 ~ +180.000 deg.	Scene center longitude

**Table 2-14 Relationship between Pixel Spacing and Multilook Numbers**

Observation Mode	Pixel Spacing	Number of Multi-look		Resolution	
		Az	Rg	Az	Rg
Spotlight	0.625m	1	1	1.0m	3.0m
	1.25m	2	1	2.0m	3.0m
	2.5m	3	1	3.0m	3.0m
Ultra-Fine	2.5m	1	1	3.0m	3.0m
	5m	2	2	6.0m	6.0m
	10m	4	4	12.0m	12.0m
High-sensitive (Single, Dual pol.)	3.125m	1	1	4.3m	6.0m
	6.25m	2	2	8.6m	12.0m
	12.5m	3	3	12.9m	18.0m
Fine (Single, Dual pol.)	6.25m	2	1	10.6m	9.1m
	12.5m	3	2	15.9m	18.2m
High-sensitive (Full (Quad.) pol.)	3.125m	1	1	4.3m	5.1m
	6.25m	2	2	8.6m	10.2m
	12.5m	3	3	12.9m	15.3m
Fine Beam (full (quad.) pol.)	6.25m	2	1	10.6m	8.7m
	12.5m	3	2	15.9m	17.4m
ScanSAR nominal (28 MHz)	25.0m	3	3	77.7m	28.5m
	50.0m	3	6	77.7m	57.0m
	100.0m	6	12	155.4m	114.0m
ScanSAR nominal (14 MHz)	25.0m	3	2	77.7m	38.0m
	50.0m	3	3	77.7m	57.0m
	100.0m	6	6	155.4m	114.0m
ScanSAR wide	25.0m	1.5	2	56.7m	44.2m
	50.0m	1.5	3	56.7m	66.3m
	100.0m	3	5	113.4m	110.5m

\* The number of multi-look in the azimuth direction is the number of effective looks in the case of ScanSAR mode.

\* The resolution is defined as the value specified when the incidence angle is 37 degrees (reference value).

## 2.6. Definition of Level 2.1 Image

The image of level 2.1 is corrected geometrically (map projection) and output as the image whose upper side is consistent with the north direction. All valid data of input level 1.1 is included in a level 2.1 image frame. The areas out of valid data are stored dummy data (zero values). (Refer to Figure 2-1)

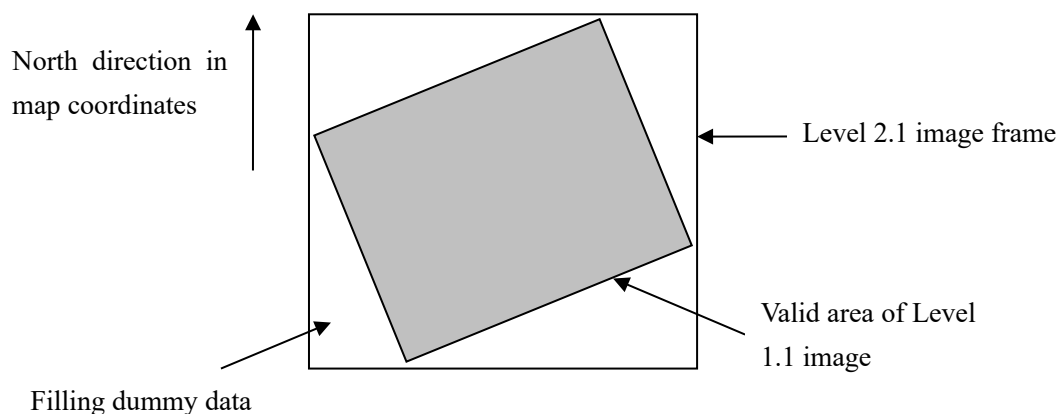

**Figure 2-1 Definition of Level 2.1 Image**

## 2.7. Notes

- If the observational mode is ScanSAR and the DEM is not specified, SRTM 90m DEM and EGM96 geoid model are used in level 2.1 processing.
- If the observational mode is other mode than ScanSAR and the DEM is not specified, the location (Japan/overseas) of a scene is determined automatically by the latitudes and longitudes of four corners of the scene and DEM is selected. When Japan region is included in a scene, GISMAP Terrain DEM and GSIGEO2000 geoid model are used in processing. In the case of other region than Japan, SRTM 90m DEM and EGM96 geoid model are used in processing.
- If the region without DEM is included in a scene, the region is processed as 0m altitude.



### 3. Product Formats

#### 3.1. Composition of CEOS Product

The overall configuration of CEOS level 2.1 product formats is shown in section 2.3. The definition of each file is shown in Table 3-1. The file structure of each polarization is represented in Figure 3-1 to Figure 3-3.

**Table 3-1 CEOS L2.1 File Composition and Definitions of File Names**

File Name	File Num.	Definition of File Name	Record name	Contents
Volume Directory File	1	VOL-Scene ID-Product ID	Volume descriptor File pointer Text	This file is located at the beginning of the image volume and stores the volume and file management information.
SAR Leader File	1	LED-Scene ID-Product ID	File descriptor Data set summary Map projection data Platform position data Attitude data Radiometric data Data quality summary Facility related data	This file is located before image file and stores annotation data, ancillary data and other types of data related to the image data in the succeeding image file.
SAR Image File	n (Number of polarization)	IMG-polarization information-Scene ID-Product ID	File descriptor Processed data record	This file is located after the leader file and stores the image data.
SAR Trailer File	1	TRL-Scene ID-Product ID	File descriptor Low resolution image data	This file is located after the image file and stores the final information related to the image data.

Scene ID = AAAAABBBBBCCCC-YYMMDD

AAAAA : Satellite/Sensor name (ALOS2)

BBBBB : Orbit accumulation number of a scene center

CCCC : Scene frame number of a scene center

-: separator

YYMMDD: Observation date of scene center (YY: lower 2 figures of a year, MM: month, DD: day)

Product ID = DDDEFFFGHI

DDD: Observation Mode

SBS: Spotlight Mode

UBS: Ultra-fine mode Single polarization

UBD: Ultra-fine mode Dual polarization

HBS: High-sensitive mode Single polarization

HBD: High-sensitive mode Dual polarization

HBQ: High-sensitive mode Full (Quad.) polarimetry

FBS: Fine mode Single polarization

FBD: Fine mode Dual polarization

FBQ: Fine mode Full (Quad.) polarimetry  
WBS: Scan SAR nominal [14MHz] mode Single polarization  
WBD: Scan SAR nominal [14MHz] mode Dual polarization  
WWS: Scan SAR nominal [28MHz] mode Single polarization  
WWD: Scan SAR nominal [28MHz] mode Dual polarization  
VBS: Scan SAR wide mode Single polarization  
VBD: Scan SAR wide mode Dual polarization

E: Observation Direction

L: Left looking, R: Right looking

FFF: Processing Level

2.1: Level 2.1

G: Processing Option

G: Geo-coded

H: Map Projection

U: UTM, P: PS, M: MER, L: LCC

I: Orbit Direction

A: Ascending, D: Descending

Polarization (Transmission and Receiving) = XX

HH: Horizontally polarized wave transmission / Horizontally polarized wave receiving

HV: Horizontally polarized wave transmission / Vertically polarized wave receiving

VH: Vertically polarized wave transmission / Horizontally polarized wave receiving

VV: Vertically polarized wave transmission / Vertically polarized wave receiving

■Single polarization

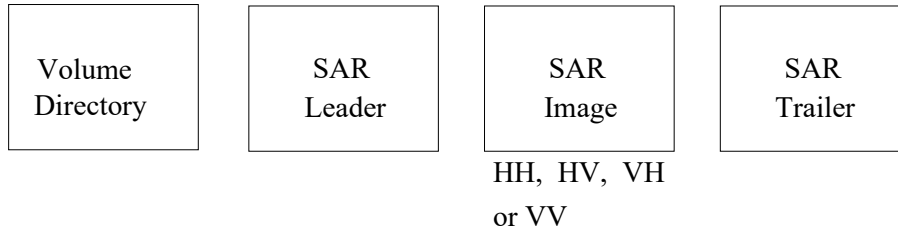

**Figure 3-1 CEOS level 2.1 file composition/Single polarization**

■Dual polarization

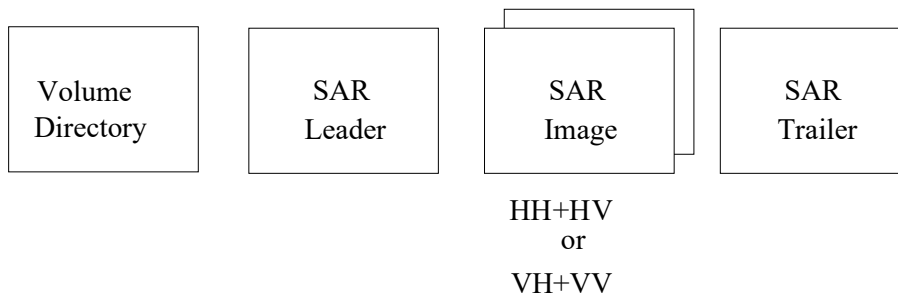

**Figure 3-2 CEOS level 2.1 file composition/Dual polarization**

■High-sensitive/Fine Mode Full (Quad.) Polarimetry

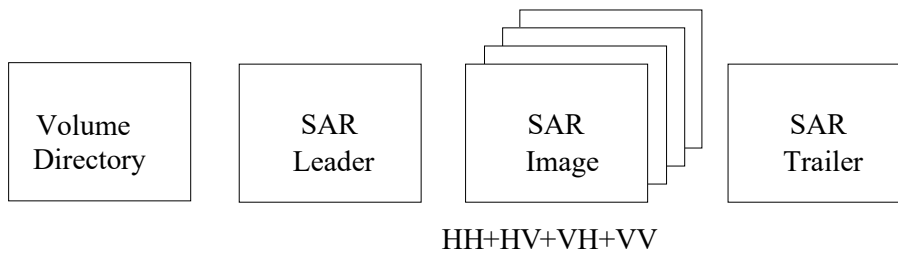

**Figure 3-3 CEOS level 2.1 file composition/Full (Quad.) Polarimetry**

### 3.2. Record Structure of CEOS Product

The record structure of CEOS level 2.1 format is shown in Table 3-2. The sizes of the processed data record are shown in Table 3-19.

**Table 3-2 Record Structure of CEOS level 2.1 Format**

Record No.	Record length [byte]	Number of records	Record name	File name
1	360	1	Volume descriptor	Volume Directory
2 to 3 + number of polarization	360	Number of polarization + 2	File pointer	
4 + number of polarization	360	1	Text	
1	720	1	File descriptor	SAR Leader
2	4,096	1	Data set summary	
3	1620	1	Map projection data	
4	4,680	1	Platform position data	
5	16,384	1	Altitude data	
6	9,860	1	Radiometric data	
7	1,620	1	Data quality summary	
8	325,000	1	Facility related data 1 (Dummy data)	
9	511,000	1	Facility related data 2 (Determined ephemeris)	
10	3,072	1	Facility related data 3 (Time error information)	
11	728,000	1	Facility related data 4 (Coordinate conversion information)	
12	5000	1	Facility related data 5 (Latitude and longitude conversion factor)	
1	720	1	File descriptor	SAR Image
2 to 1+n	Variable	n	Processed data	
1	720	1	File descriptor	SAR Trailer
2	Variable	1	Low resolution image data	

\* n: number of processed data line.

| A

### 3.2.1. Record Data Type

The definition of data type that used for description of record is shown in Table 3-3.

**Table 3-3 Definition of Data Types**

Type (code)	Details
Am	Character (Left-fill if not specified)
Im	ASCII that represents integer (Right-fill)
Fm.n	Real type data (Right-fill)
Em.n	Real type data (Exponential notation, right-fill)
Bm	Binary number representation (The first byte is the most significant, big endian)

m: Number of digits

n: Number of decimal places

p: multiplier in an index

### 3.2.2. Record Type Code and Record Sub-type Code

Each record has record type code and record sub-type code (sub-type code) in order to distinguish each other. The type code of each record is shown in Table 3-4

**Table 3-4 Record Types of Each Record**

Record name	1 <sup>st</sup> record Sub-type	Record Type	2 <sup>nd</sup> record Sub-type	3 <sup>rd</sup> record Sub-type	Record length [byte]
Volume Descriptor	192	192	18	18	360
File pointer	219	192	18	18	360
Text	18	192	18	18	360
SAR Leader file Descriptor	11	192	18	18	720
Data set summary	18	10	18	20	4,096
Map projection data	18	20	18	10	1,620
Platform position data	18	30	18	20	4,680
Attitude data	18	40	18	20	16,384
Radiometric data	18	50	18	20	9,860
Data quality summary	18	60	18	20	1,620
Facility related data	18	200	18	70	Refer to Table 3-5
SAR data file Descriptor	50	192	18	18	720
Processed data	50	11	18	20	Refer to Table 3-19
SAR Trailer file Descriptor	63	192	18	18	720
Low resolution image data	-	-	-	-	Refer to Table 3-21

\* Value is decimal

**Table 3-5 Facility Related Data Record Type**

Record name	1 <sup>st</sup> record Sub-type	Record Type	2 <sup>nd</sup> record sub-type	3 <sup>rd</sup> record sub-type	Record length [byte]
Facility related 1 (Dummy data)	18	200	18	70	325,000
Facility related 2 (Determined ephemeris)					511,000
Facility related 3 (Time error information)					3,072
Facility related 4 (Coordinate conversion information)					728,000
Facility related 5 (Latitude and longitude conversion factor)					5000

A

\* Value is decimal



### 3.3. Contents of Records in CEOS Files

Record formats are shown in Table 3-6 to Table 3-21. "b" in a table means blanks. In the case of "N)<sub>10</sub>", "N" means decimal value.

**Table 3-6 Volume descriptor records (1/2)**

Field No.	Byte No.	Type	Description	Remarks
1	1 - 4	B4	Record sequence number = 1) <sub>10</sub>	Copy the value of Level 1.1
2	5 - 5	B1	1 <sup>st</sup> record subtype code = 192) <sub>10</sub>	Copy the value of Level 1.1
3	6 - 6	B1	Record type code = 192) <sub>10</sub>	Copy the value of Level 1.1
4	7 - 7	B1	2 <sup>nd</sup> record subtype code = 18) <sub>10</sub>	Copy the value of Level 1.1
5	8 - 8	B1	3 <sup>rd</sup> record subtype code = 18) <sub>10</sub>	Copy the value of Level 1.1
6	9 - 12	B4	Length of this record = 360) <sub>10</sub>	Copy the value of Level 1.1
7	13 - 14	A2	ASCII/EBCDIC flag = 'Ab': ASCII	Copy the value of Level 1.1
8	15 - 16	A2	Blanks	Copy the value of Level 1.1
9	17 - 28	A12	Superstructure format control document ID = 'CEOS-SARbbbb'	Copy the value of Level 1.1
10	29 - 30	A2	Superstructure format control document revision level = 'NN' NN: 'bA'~'bZ'	Copy the value of Level 1.1
11	31 - 32	A2	Superstructure record format revision level = 'NN' NN: 'bA'~'bZ'	Copy the value of Level 1.1
12	33 - 44	A12	Software release and revision level = 'NNN.NNNbbbbbbb' 001.000, 001.001, ... 001.100, ...002.000	
13	45 - 60	A16	Physical volume ID Spacecraft Control Mission Operation system = 'SCMObbbbbbbbbbb' Earth Intelligence Collection and Shearing System = 'EICSbbbbbbbbbbbb'	
14	61 - 76	A16	Logical volume ID = 'MMNSSSYYYYMMDDbb' MM : Mission ID (ALOS2='AL')(*) N : Mission Number (=2')(*) SSS : Sensor ID (SAR='SAR')(*) YYYY : Product generation year MM : Product generation month DD : Product generation day	(*)Copy the value of Level 1.1
15	77 - 92	A16	Volume set ID = 'MMMMMMbSSSbbbbbb' MMMMMM : Mission name (ALOS2='ALOS2b') SSS : Sensor name (SAR='SAR')	Copy the value of Level 1.1
16	93 - 94	I2	Total number of physical volumes in the logical volume = 'b1'	Copy the value of Level 1.1
17	95 - 96	I2	Physical volume sequence number of the first tape = 'b1'	Copy the value of Level 1.1

A

**Table 3-6 Volume descriptor records (2/2)**

Field No.	Byte No.	Type	Description	Remarks
18	97 - 98	I2	Physical volume sequence number of the last tape = 'b1'	Copy the value of Level 1.1
19	99 - 100	I2	Physical volume sequence number of the current tape = 'b1'	Copy the value of Level 1.1
20	101 - 104	I4	File number in the logical volume follows volume directory file. = 'bbb3'~'bbb6': N+2 (N is number of polarization) (Leader, Image, Trailer)	Copy the value of Level 1.1
21	105 - 108	I4	Logical volume within a volume set = 'bbb1'	Copy the value of Level 1.1
22	109 - 112	I4	Logical volume number within physical volume = 'bbb1'	Copy the value of Level 1.1
23	113 - 120	A8	Logical volume creation data = 'YYYYMMDD'(Without zero suppression) YYYY : Year MM : Month DD : Day	
24	121 - 128	A8	Logical volume creation time = 'HHMMSSXX'(Without zero suppression) HH : Hour MM : Minute SS : Second XX : 10mili-second	
25	129 - 140	A12	Logical volume generation country (JAPAN) = 'JAPANbbbbbbb'	Copy the value of Level 1.1
26	141 - 148	A8	Logical volume generating agency (Japan Aerospace Exploration Agency) = 'JAXAbbbb'	Copy the value of Level 1.1
27	149 - 160	A12	Logical volume generating facility Spacecraft Control and Mission Operation System = 'SCMObbbbbbb' Earth Intelligence Collection and Shearing Earth Intelligence Collection and Shearing System = 'EICSbbbbbbb'	
28	161 - 164	I4	Number of file pointer records in volume directory = ' N+2 (N is number of polarization)'	
29	165 - 168	I4	Number of text records in volume directory = 'bbb1'	Copy the value of Level 1.1
30	169 - 260	A92	Volume descriptor Spare = Blanks	Copy the value of Level 1.1
31	261 - 360	A100	Local use segment = Blanks	Copy the value of Level 1.1

**Table 3-7 File pointer records (1/3)**

Field No.	Byte No.	Type	Description	Remarks
1	1 - 4	B4	Record number Single Polarization Leader file = 2) <sub>10</sub> Image file = 3) <sub>10</sub> Trailer file = 4) <sub>10</sub> Dual polarization Leader file = 2) <sub>10</sub> Image file = 3), 4) <sub>10</sub> Trailer file = 5) <sub>10</sub> Full (Quad.) polarimetry(four polarization) Leader file = 2) <sub>10</sub> Image file = 3), 4), 5), 6) <sub>10</sub> Trailer file = 7) <sub>10</sub>	
2	5 - 5	B1	1 <sup>st</sup> record Sub-type code = 219) <sub>10</sub>	Copy the value of Level 1.1
3	6 - 6	B1	Record type code = 192) <sub>10</sub>	Copy the value of Level 1.1
4	7 - 7	B1	2 <sup>nd</sup> sub-type code = 18) <sub>10</sub>	Copy the value of Level 1.1
5	8 - 8	B1	3 <sup>rd</sup> sub-type code = 18) <sub>10</sub>	Copy the value of Level 1.1
6	9 - 12	B4	Record length = 360) <sub>10</sub>	Copy the value of Level 1.1
7	13 - 14	A2	ASCII/EBCDIC code = 'Ab': ASCII	Copy the value of Level 1.1
8	15 - 16	A2	Blanks	Copy the value of Level 1.1
9	17 - 20	I4	Referenced file number Leader file = 'bbb1' Image file = 'bbb2' Trailer file = 'bbb3'	Copy the value of Level 1.1

**Table 3-7 File pointer records (2/3)**

Field No.	Byte No.	Type	Description	Remarks
10	21 - 36	A16	Referenced File name ID = 'MMNbSSSTFFFFbbbb' MM : Mission ID (ALOS2='AL')(*) N : Mission number (=2')(*) SSS : Sensor ID (SAR='SAR')(*) T : Processing level code Level 2.1 = 'E' FFFF : File Type(*) Leader file = 'SARL' Image file = 'IMOP' Trailer = 'SART'	(*)Copy the value of Level 1.1
11	37 - 64	A28	Referenced file class Leader file = 'SARLEADERbFILEbbbbbbbbbbbb' Image file = 'IMAGERYbOPTIONSbFILEbbbbbbbb' Trailer file = 'SARTRAILERbFILEbbbbbbbbbbbb'	Copy the value of Level 1.1
12	65 - 68	A4	Reference file class code Leader file = 'SARL' Image file = 'IMOP' Trailer file = 'SART'	Copy the value of Level 1.1
13	69 - 96	A28	Referenced file data Type = 'MIXEDbBINARYbANDBASCIIbbbbbb'	Copy the value of Level 1.1
14	97 - 100	A4	Referenced file data Type code = 'MBAA'(Mixed Binary And ASCII)	Copy the value of Level 1.1
15	101 - 108	I8	Number of records in referenced file Leader file = 'bbbbbb12' Image file = N+1 (N is the number of image data records) Trailer file = 'bbbbbb2'	
16	109 - 116	I8	Length of the first record in referenced file = 'bbbbbb720'	Copy the value of Level 1.1
17	117 - 124	I8	Maximum record length in referenced file	bbbbnnnn

B

**Table 3-7 File pointer records (3/3)**

Field No.	Byte No.	Type	Description	Remarks
18	125 - 136	A12	Referenced file record length type Leader file = 'VARIABLEbLEN' Image file = 'VARIABLEbLEN' Trailer file = 'VARIABLEbLEN '	Copy the value of Level 1.1
19	137 - 140	A4	Referenced file record length type code Leader file = 'VARE' Image file = 'VARE' Trailer file = 'VARE'	Copy the value of Level 1.1
20	141 - 142	I2	The number of the physical volume set containing the first record of the file = 'b1'	Copy the value of Level 1.1
21	143 - 144	I2	The number of the physical volume set containing the last record of the file = 'b1'	Copy the value of Level 1.1
22	145 - 152	I8	Record number of the first record appearing on this physical volume = 'bbbbbb1'	Copy the value of Level 1.1
23	153 - 160	I8	Record number of the last record appearing on this physical volume Leader file = 'bbbbbb12' Image file = N+1 (N is the number of image data records) Trailer file = 'bbbbbb2'	
24	161 - 260	A100	Spare = Blanks	Copy the value of Level 1.1
25	261 - 360	A100	Local use segment = Blanks	Copy the value of Level 1.1

B

**Table 3-8 Text records (1/2)**

Field No.	Byte No.	Type	Description	Remarks
1	1 - 4	B4	Record number = $N + 4)_{10}$ (N = 'Number of polarization')	Copy the value of Level 1.1
2	5 - 5	B1	1 <sup>st</sup> record sub-type code = $18)_{10}$	Copy the value of Level 1.1
3	6 - 6	B1	Record type code = $192)_{10}$	Copy the value of Level 1.1
4	7 - 7	B1	2 <sup>nd</sup> sub-type code = $18)_{10}$	Copy the value of Level 1.1
5	8 - 8	B1	3 <sup>rd</sup> sub-type code = $18)_{10}$	Copy the value of Level 1.1
6	9 - 12	B4	Record length = $360)_{10}$	Copy the value of Level 1.1
7	13 - 14	A2	ASCII/EBCDIC code = 'Ab': ASCII	Copy the value of Level 1.1
8	15 - 16	A2	Blanks	Copy the value of Level 1.1
9	17 - 56	A40	Product ID = 'PRODUCT: DDDEFFFGHIbbbbbbbbbbbbbbbbbbbb' DDD: Observation mode (*) SBS: Spotlight mode UBS: Ultra-fine mode (Single pol.) UBD: Ultra-fine mode (Dual pol.) HBS: High-sensitive mode (Single pol.) HBD: High-sensitive mode (Dual pol.) HBQ: High-sensitive mode (Full(Quad.) pol.) FBS: Fine mode (Single pol.) FBD: Fine mode (Dual pol.) FBQ: Fine mode (Full (Quad.) pol.) WBS: ScanSAR nominal [14MHz] mode (Single pol.) WBD: ScanSAR nominal [14MHz] mode (Dual pol.) WWS: ScanSR nominal [28MHz,] mode (Single pol.) WWD: ScanSAR nominal [28MHz] mode (Dual pol.) VBS: ScanSAR wide mode (Single pol.) VBD: ScanSAR wide mode (Dual pol.) E : Observation direction (*) L: Left looking R: Right looking	(*) Copy the value of Level 1.1

**Table 3-8 Text records (2/2)**

Field No.	Byte No.	Type	Description	Remarks
			FFF: Processing level 2.1: Level 2.1 G : Processing option G: Geo-Coded H : Map projection U: UTM P: PS M: MER L: LCC I : Ascending node (*) A: Ascending D: Descending	(*) Copy the value of Level 1.1
10	57 - 116	A60	Location and date/time of product creation Spacecraft Control Mission Operation system = 'PROCESS: JAPAN-JAXA-ALOS2-SCMObbYYYYMMDDbHHMMSSb...b' Earth Intelligence Collection and Shearing system = 'PROCESS: JAPAN-JAXA-ALOS2-EICsbYYYYMMDDbHHMMSSb...b' (without zero suppress both) YYYYMMDD : Date of creation (YYYY: Year, MM: Month, DD: Day) HHMMSS : Time of Creation (UTC)	
11	117 - 156	A40	Physical tape ID = 'TAPEbID: bbbbbb'	Copy the value of Level 1.1
12	157 - 196	A40	Scene ID = 'ORBITb: AAAAABBBBBBCCCC-YMMDDbbbbbb' AAAA : Satellite (= 'ALOS2') BBBB : Orbit accumulation number of a scene center CCCC : Scene frame number of a scene center - : Separator (hyphen) YMMDD : Observation date of a scene center (YY: lower 2 figures of a year, MM: month, DD: day)	Copy the value of Level 1.1
13	197 - 236	A40	Scene location ID = 'FRAMEbCENTRE: bN±nnn.nnbE±nnn.nbbbbbb': Level 2.1 N±nnn.nn : Latitude of a scene center [deg] E±nnn.nn : Longitude of a scene center [deg]	Copy the value of Level 1.1
14	237 - 360	A124	Blanks	Blanks (b*124)



**Table 3-9 SAR Leader file descriptor records (1/3)**

Field No.	Byte No.	Type	Description	Remarks
1	1 - 4	B4	Record number = 1) <sub>10</sub>	Copy the value of Level 1.1
2	5 - 5	B1	1 <sup>st</sup> record sub-type code = 11) <sub>10</sub>	Copy the value of Level 1.1
3	6 - 6	B1	Record type code = 192) <sub>10</sub>	Copy the value of Level 1.1
4	7 - 7	B1	2 <sup>nd</sup> sub-type code = 18) <sub>10</sub>	Copy the value of Level 1.1
5	8 - 8	B1	3 <sup>rd</sup> sub-type code = 18) <sub>10</sub>	Copy the value of Level 1.1
6	9 - 12	B4	Record length = 720) <sub>10</sub>	Copy the value of Level 1.1
7	13 - 14	A2	ASCII/EBCDIC code = 'Ab': ASCII	Copy the value of Level 1.1
8	15 - 16	A2	Blanks	Copy the value of Level 1.1
9	17 - 28	A12	Format control document ID = 'CEOS-SARbbbb'	Copy the value of Level 1.1
10	29 - 30	A2	Format control document revision level = 'bA'	Copy the value of Level 1.1
11	31 - 32	A2	Record format revision level = 'bA'	Copy the value of Level 1.1
12	33 - 44	A12	Software release and revision level = 'NNN.NNNbbbbbb' 001.000, 001.001, ... 001.100, ...002.000	Copy the value of Level 1.1
13	45 - 48	I4	File number = 'bbb1'	Copy the value of Level 1.1
14	49 - 64	A16	File ID = 'MMNbSSSTFFFFbbbb' MM : Mission ID (ALOS2='AL')(*) N : Mission number (=2')(*) SSS : Sensor ID (SAR='SAR')(*) T : Processing level code Level 2.1 = 'E' FFFF : File Type(*) Leader file = 'SARL' Image file = 'IMOP' Trailer file = 'SART'	(*) Copy the value of Level 1.1
15	65 - 68	A4	Record sequence and location type flag = 'FSEQ'	Copy the value of Level 1.1

A

**Table 3-9 SAR Leader file descriptor records (2/3)**

Field No.	Byte No.	Type	Description	Remarks
16	69 - 76	I8	Sequence number of location = 'bbbbbb1'	Copy the value of Level 1.1
17	77 - 80	I4	Field length of sequence number = 'bbb4'	Copy the value of Level 1.1
18	81 - 84	A4	Record code and location type flag = 'FTYP'	Copy the value of Level 1.1
19	85 - 92	I8	Location of record code = 'bbbbbb5'	Copy the value of Level 1.1
20	93 - 96	I4	Field length of record code = 'bbb4'	Copy the value of Level 1.1
21	97 - 100	A4	Record length and location type flag = 'FLGT'	Copy the value of Level 1.1
22	101 - 108	I8	Location of record length = 'bbbbbb9'	Copy the value of Level 1.1
23	109 - 112	I4	Field length of record length = 'bbb4'	Copy the value of Level 1.1
24	113 - 180	A68	Blanks	Copy the value of Level 1.1
25	181 - 186	I6	Number of data set summary records = 'bbbb1'	Copy the value of Level 1.1
26	187 - 192	I6	Data set summary record length = 'bb4096'	Copy the value of Level 1.1
27	193 - 198	I6	Number of map projection data records = 'bbbb1'	
28	199 - 204	I6	Map projection data record length = 'bb1620'	
29	205 - 210	I6	Number of platform position data records = 'bbbb1'	Copy the value of Level 1.1
30	211 - 216	I6	Platform position record length = 'bb4680'	Copy the value of Level 1.1
31	217 - 222	I6	Number of attitude data records = 'bbbb1'	Copy the value of Level 1.1
32	223 - 228	I6	Attitude data record length = 'b16384'	Copy the value of Level 1.1
33	229 - 234	I6	Number of radiometric data records = 'bbbb1'	Copy the value of Level 1.1
34	235 - 240	I6	Radiometric record length = 'bb9860'	Copy the value of Level 1.1
35	241 - 246	I6	Number of radiometric compensation records = 'bbbb0'	Copy the value of Level 1.1
36	247 - 252	I6	Radiometric compensation record length = 'bbbb0'	Copy the value of Level 1.1
37	253 - 258	I6	Number of data quality summary records = 'bbbb1'	Copy the value of Level 1.1
38	259 - 264	I6	Data quality summary record length = 'bb1620'	Copy the value of Level 1.1
39	265 - 270	I6	Number of data histograms records = 'bbbb0'	Copy the value of Level 1.1
40	271 - 276	I6	Data histogram record length = 'bbbb0'	Copy the value of Level 1.1

**Table 3-9 SAR Leader file descriptor records (3/3)**

Field No.	Byte No.	Type	Description	Remarks
41	277 - 282	I6	Number of range spectra records = 'bbbbbb0'	Copy the value of Level 1.1
42	283 - 288	I6	Range spectra record length = 'bbbbbb0'	Copy the value of Level 1.1
43	289 - 294	I6	Number of DEM descriptor records = 'bbbbbb0'	Copy the value of Level 1.1
44	295 - 300	I6	DEM descriptor record length = 'bbbbbb0'	Copy the value of Level 1.1
45	301 - 306	I6	Number of radar parameter update records = 'bbbbbb0'	Copy the value of Level 1.1
46	307 - 312	I6	Radar parameter update record length = 'bbbbbb0'	Copy the value of Level 1.1
47	313 - 318	I6	Number of annotation data records = 'bbbbbb0'	Copy the value of Level 1.1
48	319 - 324	I6	Annotation data record length = 'bbbbbb0'	Copy the value of Level 1.1
49	325 - 330	I6	Number of detail processing records = 'bbbbbb0'	Copy the value of Level 1.1
50	331 - 336	I6	Detail processing record length = 'bbbbbb0'	Copy the value of Level 1.1
51	337 - 342	I6	Number of calibration records = 'bbbbbb0'	Copy the value of Level 1.1
52	343 - 348	I6	Calibration record length = 'bbbbbb0'	Copy the value of Level 1.1
53	349 - 354	I6	Number of GCP records = 'bbbbbb0'	Copy the value of Level 1.1
54	355 - 360	I6	GCP record length = 'bbbbbb0'	Copy the value of Level 1.1
55	361 - 420	10A6	Spare	Copy the value of Level 1.1
56	421 - 426	I6	Number of facility data(1) records = 'bbbbbb1'	Copy the value of Level 1.1
57	427 - 434	I8	Facility data(1) record length = 'bb325000'	Copy the value of Level 1.1
58	435 - 440	I6	Number of facility data(1) records = 'bbbbbb1'	Copy the value of Level 1.1
59	441 - 448	I8	Facility data(2) record length = 'bb511000'	Copy the value of Level 1.1
60	449 - 454	I6	Number of facility data(2) records = 'bbbbbb1'	Copy the value of Level 1.1
61	455 - 462	I8	Facility data(3) record length = 'bbbb3072'	Copy the value of Level 1.1
62	463 - 468	I6	Number of facility data(3) records = 'bbbbbb1'	Copy the value of Level 1.1
63	469 - 476	I8	Facility data(4) record length = 'bb728000'	Copy the value of Level 1.1
64	477 - 482	I6	Number of facility data(5) records = 'bbbbbb1'	Copy the value of Level 1.1
65	483 - 490	I8	Facility data(5) record length = 'bbbb5000'	Copy the value of Level 1.1
66	491 - 720	A230	Blanks	Copy the value of Level 1.1

**Table 3-10 Data set summary records (1/12)**

Field No.	Byte No.	Type	Description	Remarks
1	1 - 4	B4	Records number = 2) <sub>10</sub>	Copy the value of Level 1.1
2	5 - 5	B1	1 <sup>st</sup> record sub-type code = 18) <sub>10</sub>	Copy the value of Level 1.1
3	6 - 6	B1	Record type code = 10) <sub>10</sub>	Copy the value of Level 1.1
4	7 - 7	B1	2 <sup>nd</sup> record sub-type code = 18) <sub>10</sub>	Copy the value of Level 1.1
5	8 - 8	B1	3 <sup>rd</sup> record sub-type code = 20) <sub>10</sub>	Copy the value of Level 1.1
6	9 - 12	B4	Data set summary records length = 4096) <sub>10</sub>	Copy the value of Level 1.1
7	13 - 16	I4	Data set summary records sequence number = 'bbb1'	Copy the value of Level 1.1
8	17 - 20	A4	SAR channel ID = Blanks (fixed value)	Copy the value of Level 1.1
9	21 - 52	A32	Scene ID = 'AAAAABBBBBCCCC-YYMMDDbbbbbbbbbb' AAAAA : Satellite ID (= 'ALOS2') BBBBB : Orbit accumulation number of a scene center CCCC : Scene frame number of a scene center - : Separator (hyphen) YYMMDD : Observation date of a scene center (YY: lower 2 figures of a year, MM: month, DD: day)	Copy the value of Level 1.1
10	53 - 68	A16	Number of scene reference = Blanks (fixed value)	Copy the value of Level 1.1
11	69 - 100	A32	Scene center time = 'YYYYMMDDHHMMSSttbbbbbbbbbbbbbb' (Without zero suppression, YYY: year, MM: month, DD: day) HHMMSStt : Time (UTC)	Copy the value of Level 1.1
12	101 - 116	A16	Spare = Blanks (fixed value)	Copy the value of Level 1.1
13	117 - 132	F16.7	Geodetic latitude (defined as positive to the north of the equator and negative to the south) of processed scene center [deg] = Positive value to the north of the equator = Negative value to the south of the equator	
14	133 - 148	F16.7	Geodetic longitude (defined as positive to the east of the prime meridian and negative to the west) of processed scene center [deg] = Positive value to the east of the prime meridian = Positive value to the west of the prime meridian	
15	149 - 164	F16.7	Processed scene center true heading [deg] = Value	

**Table 3-10 Data set summary records (2/12)**

Field No.	Byte No.	Type	Description	Remarks
16	165 - 180	A16	Ellipsoid designator = 'GRS80bbbbbbbbbb'(fixed value)	Copy the value of Level 1.1
17	181 - 196	F16.7	Ellipsoid semi-major axis [km] = 6378.1370000	Copy the value of Level 1.1
18	197 - 212	F16.7	Ellipsoid semi-minor axis [km] = 6356.7523141	Copy the value of Level 1.1
19	213 - 228	F16.7	Earth mass [ $10^{24}$ kg] = 5.9740000	Copy the value of Level 1.1
20	229 - 244	F16.7	Gravitational constant [ $10^{-14}$ m <sup>3</sup> /s <sup>2</sup> ] = 3.9860050	Copy the value of Level 1.1
21	245 - 260	F16.7	Ellipsoid J2 parameter = $0.1082629 \times 10^{-2}$	Copy the value of Level 1.1
22	261 - 276	F16.7	Ellipsoid J3 parameter = $-0.0000254 \times 10^{-1}$	Copy the value of Level 1.1
23	277 - 292	F16.7	Ellipsoid J4 parameter = $-0.0000162 \times 10^{-1}$	Copy the value of Level 1.1
24	293 - 308	A16	Spare = Blanks(fixed value)	Copy the value of Level 1.1
25	309 - 324	F16.7	Average terrain height above ellipsoid at scene center = Blanks (fixed value)	Copy the value of Level 1.1
26	325 - 332	I8	Scene center line No. (Including zero fill)	N/2 (N: number of lines)
27	333 - 340	I8	Scene center pixel No. (Including zero fill)	M/2 (M: number of pixels)
28	341 - 356	F16.7	Processing scene length [km] = Blanks (fixed value)	Copy the value of Level 1.1
29	357 - 372	F16.7	Processed scene width [km] = Blanks (fixed value)	Copy the value of Level 1.1
30	373 - 388	A16	Spare = Blanks (fixed value)	Copy the value of Level 1.1
31	389 - 392	I4	Number of SAR channel = 'bbbn' Single Beam type 2: Fine [10m] mode (Single pol.) 4: Fine [10m] mode (Dual pol., Full (Quad.) pol.) Dual beam type 4: Spotlight mode, High-resolution mode (Single pol.), ScanSAR mode (Single pol.) 8: High resolution mode (Dual pol., Full (Quad.) pol.) ScanSAR mode (Dual pol.)	Copy the value of Level 1.1
32	393 - 396	A4	Spare = Blanks (fixed value)	Copy the value of Level 1.1
33	397 - 412	A16	Sensor platform mission identifier (ID) = 'ALOS2bbbbbbbbbb'	Copy the value of Level 1.1

**Table 3-10 Data set summary records (3/12)**

Field No.	Byte No.	Type	Description	Remarks
34	413 - 444	A32	Sensor ID and operation mode = 'AAAAAA-BB-CCDD-bbbbbbbbbbbbbbbb' AAAAAA : Satellite ID (=ALOS2b) BB : SAR band (=Lb) CC : Operation mode '00': Spotlight mode '01': Ultra-fine mode '02': High-sensitive mode '03': Fine mode '08': ScanSAR nominal mode '09': ScanSAR wide mode '18': Full (Quad.) pol./High-sensitive mode '19': Full (Quad.) pol./Fine mode DD : Calibration mode '15': During observation	Copy the value of Level 1.1

A

**Table 3-10 Data set summary records (4/12)**

Field No.	Byte No.	Type	Description	Remarks
35	445 - 452	I8	Orbit number or flight line indicator	Copy the value of Level 1.1
36	453 - 460	F8.3	Sensor platform geodetic latitude at nadir corresponding to scene center [deg] = Value Blanks	
37	461 - 468	F8.3	Sensor platform geodetic longitude at nadir corresponding to scene center [deg] = Value Blanks	
38	469 - 476	F8.3	Sensor platform heading at nadir corresponding to scene center [deg] = Value Blanks	
39	477 - 484	F8.3	Sensor clock angle as measured relative to sensor platform flight direction [deg] Left = 'b-90.000' Right = 'bb90.000'	Copy the value of Level 1.1
40	485 - 492	F8.3	Incidence angle at scene center [deg] = Value	Copy the value of Level 1.1
41	493 - 500	A8	Spare = Blanks	Copy the value of Level 1.1
42	501 - 516	F16.7	Radar wavelength [m] = Nominal value	Copy the value of Level 1.1
43	517 - 518	A2	Motion compensation indicator = '00'(fixed value) 00 : No. compensation 01 : on board compensation 10 : in processor compensation 11 : both on board and in processor	Copy the value of Level 1.1
44	519 - 534	A16	Range pulse code = 'LINEARbFMbCHIRPb'	Copy the value of Level 1.1
45	535 - 550	E16.7	Range pulse amplitude coefficient #1 = Nominal value Center frequency $\xi_1$ for pulse width $\tau$ of linearFMmodulationchirp (Constant term)	Copy the value of Level 1.1
46	551 - 566	E16.7	Range pulse amplitude coefficient #2 = Nominal value FMrate $\xi_2$ for pulse width $\tau$ of linearFMmodulationchirp (Linear coefficient terms)	Copy the value of Level 1.1
47	567 - 582	E16.7	Range pulse amplitude coefficient #3 = Nominal value (= 0.0) FMrate $\xi_3$ for pulse width $\tau$ of linearFMmodulationchirp (Quadratic coefficient terms)	Copy the value of Level 1.1
48	583 - 598	E16.7	Range pulse amplitude coefficient #4 = Nominal value (= 0.0) FMrate $\xi_4$ for pulse width $\tau$ of linearFMmodulationchirp (Cubic coefficient terms)	Copy the value of Level 1.1
49	599 - 614	E16.7	Range pulse amplitude coefficient #5 = Nominal value (= 0.0) FMrate $\xi_5$ for pulse width $\tau$ of linearFMmodulationchirp (Quartic term coefficient)	Copy the value of Level 1.1

**Table 3-10 Data set summary records (5/12)**

Field No.	Byte No.	Type	Description	Remarks
50	615 - 630	E16.7	Range pulse phase coefficient # 1 (Constant term) = Blanks (fixed value)	Copy the value of Level 1.1
51	631 - 646	E16.7	Range pulse phase coefficient # 2 (Linear coefficient terms)= Blanks (fixed value)	Copy the value of Level 1.1
52	647 - 662	E16.7	Range pulse phase coefficient # 3 (Quadratic coefficient terms) = Blanks (fixed value)	Copy the value of Level 1.1
53	663 - 678	E16.7	Range pulse phase coefficient # 4 (Cubic coefficient terms) = Blanks (fixed value)	Copy the value of Level 1.1
54	679 - 694	E16.7	Range pulse phase coefficient # 5 (Quartic term coefficient) = Blanks (fixed value)	Copy the value of Level 1.1
55	695 - 702	I8	Down linked data chirp extraction index linear-up chirp = 'bbbbbb0' linear-down chirp = 'bbbbbb1' linear-up and -down chirp = 'bbbbbb2'	Copy the value of Level 1.1
56	703 - 710	A8	Spare = Blanks	Copy the value of Level 1.1
57	711 - 726	F16.7	Sampling rate [MHz] Extracted from auxiliary data of first PALSAR frame	Copy the value of Level 1.1
58	727 - 742	F16.7	Range gate (early edge (in time) at the start of the image) [µsec] Extracted from auxiliary data of first PALSAR frame	Copy the value of Level 1.1
59	743 - 758	F16.7	Range pulse width [µsec] Extracted from auxiliary data of first PALSAR frame	Copy the value of Level 1.1
60	759 - 762	A4	Base band conversion flag = 'YESb' (fixed value)	Copy the value of Level 1.1
61	763 - 766	A4	Range compressed flag = 'YESb': Level 1.1 or later: range compressed (fixed value)	Copy the value of Level 1.1
62	767 - 782	F16.7	Receiver gain for like polarized at early edge at the start of the image = Nominal value	Copy the value of Level 1.1
63	783 - 798	F16.7	Receiver gain for cross polarized at early edge at the start of the image = Nominal value	Copy the value of Level 1.1
64	799 - 806	I8	Quantization in bits per channel = 'bbbbbb8'	Copy the value of Level 1.1
65	807 - 818	A12	quantized descriptor = 'UNIFORMbI,Qb'	Copy the value of Level 1.1
66	819 - 834	F16.7	DC Bias for I-component = Nominal value	Copy the value of Level 1.1
67	835 - 850	F16.7	DC Bias for Q-component = Nominal value	Copy the value of Level 1.1
68	851 - 866	F16.7	Gain imbalance for I & Q = Nominal value	Copy the value of Level 1.1
69	867 - 882	F16.7	Spare = Blanks (fixed value)	Copy the value of Level 1.1
70	883 - 898	F16.7	Spare = Blanks (fixed value)	Copy the value of Level 1.1
71	899 - 914	F16.7	electronic boresight = fixed value	Copy the value of Level 1.1
72	915 - 930	F16.7	mechanical boresight = fixed value	Copy the value of Level 1.1
73	931 - 934	A4	Echo tracker-on/off = 'OFFb' (fixed value)	Copy the value of Level 1.1
74	935 - 950	F16.7	PRF[mHz]	Copy the value of Level 1.1
75	951 - 966	F16.7	Two-way antenna beam width [deg] (Elevation, Effective value) = Nominal value	Copy the value of Level 1.1
76	967 - 982	F16.7	Two-way antenna beam width [deg] (Azimuth, Effective value) = Nominal value	Copy the value of Level 1.1



**Table 3-10 Data set summary records (6/12)**

Field No.	Byte No.	Type	Description	Remarks
77	983 - 998	I16	Satellite encoded binary time code: Standard satellite time counter of error time information (Tref)	Copy the value of Level 1.1
78	999 - 1030	A32	Satellite clock time: Standard ground time of error time information (Tgref)	Copy the value of Level 1.1
79	1031 - 1046	I16	Satellite clock increment [nsec]: Error time information of calculation satellite counter cycle (Psc)	Copy the value of Level 1.1
80	1047 - 1062	A16	Processing facility ID Spacecraft Control Mission Operation system = 'SCMObbbbbbbbbb' Earth Intelligence Collection and Shearing System = 'EICSbbbbbbbbbb'	
81	1063 - 1070	A8	Processing system ID Spacecraft Control Mission Operation System = 'SCMObbbb' Earth Intelligence Collection and Shearing System = 'EICSbbbb'	
82	1071 - 1078	A8	Processing version ID='NNN.NNNb' Note: This is the same as first 8 characters of software release and version ID for volume descriptor	
83	1079 - 1094	A16	Processing code of processing facility = Blanks (fixed value)	Copy the value of Level 1.1
84	1095 - 1110	A16	Product level code = '2.1bbbbbbbbbb'	
85	1111 - 1142	A32	Product type specifier = 'CORRECTEDbGEOCODEDbIMAGEbbbbbb'	
86	1143 - 1174	A32	Processing algorithm ID = Blanks (fixed value)	Copy the value of Level 1.1
87	1175 - 1190	F16.7	Number of looks in azimuth = Value	
88	1191 - 1206	F16.7	Number of looks in range = Value	
89	1207 - 1222	F16.7	Bandwidth per look in azimuth [Hz] = Blanks	
90	1223 - 1238	F16.7	Bandwidth per look in range [Hz] = Blanks	
91	1239 - 1254	F16.7	Bandwidth in azimuth [Hz] 3dB down width of power spectrum of the reference function for full aperture ScanSAR: Blanks	
92	1255 - 1270	F16.7	Bandwidth in range [kHz] = Blanks	
93	1271 - 1302	A32	Weighing function in azimuth = 'bbbbbbbbbbbbbbbbbbbbbbbbbbbb1': RECTANGLE	Copy the value of Level 1.1
94	1303 - 1334	A32	Weighing function in range = 'bbbbbbbbbbbbbbbbbbbbbbbbbb1': RECTANGLE	Copy the value of Level 1.1
95	1335 - 1350	A16	Data input source (eg.HDDT-ID) = 'ONLINEbbbbbb': Online transfer (fixed value)	Copy the value of Level 1.1

A

**Table 3-10 Data set summary records (7/12)**

Field No.	Byte No.	Type	Description	Remarks
96	1351 - 1366	F16.7	Resolution in ground range [m] = Nominal value * number of looks in range direction	
97	1367 - 1382	F16.7	Resolution in azimuth [m] = Nominal value * number of looks in azimuth direction	
98	1383 - 1398	F16.7	Radiometric parameter (Bias) = Blanks (fixed value)	Copy the value of Level 1.1
99	1399 - 1414	F16.7	Radiometric parameter (Gain) = Blanks (fixed value)	Copy the value of Level 1.1
100	1415 - 1430	F16.7	Along track Doppler frequency (center) constant term at early edge of image [Hz] =Blanks	
101	1431 - 1446	F16.7	Along track Doppler frequency (center) linear coefficient terms at early edge of image [Hz/pixel] = Blanks	
102	1447 - 1462	F16.7	Along track Doppler frequency (center) quadratic coefficient terms at early edge of image [Hz/pixel/pixel] = Blanks	
103	1463 - 1478	A16	Spare = Blanks (fixed value)	Copy the value of Level 1.1
104	1479 - 1494	F16.7	Cross track Doppler frequency (center) constant term at early edge of image [Hz] = Blanks	
105	1495 - 1510	F16.7	Cross track Doppler frequency (center) linear coefficient terms at early edge of image [Hz/pixel] = Blanks	
106	1511 - 1526	F16.7	Cross track Doppler frequency (center) quadratic coefficient terms at early edge of image [Hz/pixel/pixel] = Blanks	
107	1527 - 1534	A8	Time direction indicator along pixel direction = Blanks (fixed value)	Copy the value of Level 1.1
108	1535 - 1542	A8	Time direction indicator along line direction (Nominal value) Ascending = 'ASCENDbb' Descending = 'DESCENDb'	Copy the value of Level 1.1

A

B

A

**Table 3-10 Data set summary records (8/12)**

Field No.	Byte No.	Type	Description	Remarks
109	1543 - 1558	F16.7	Along track Doppler frequency rate constant terms at early edge of the image [Hz/sec] = Blanks	
110	1559 - 1574	F16.7	Along track Doppler frequency rate linear coefficient at early edge of the image [Hz/sec/pixel] = Blanks	
111	1575 - 1590	F16.7	Along track Doppler frequency rate quadratic coefficient at early edge of the image [Hz/sec/pixel/pixel] = Blanks	
112	1591 - 1606	A16	Spare = Blanks (fixed value)	Copy the value of Level 1.1
113	1607 - 1622	F16.7	Cross track Doppler frequency rate constant terms at early edge of the image [Hz/sec] = Blanks	
114	1623 - 1638	F16.7	Cross track Doppler frequency rate linear coefficient at early edge of the image [Hz/sec/pixel] = Blanks	
115	1639 - 654	F16.7	Cross track Doppler frequency rate quadratic coefficient at early edge of the image [Hz/sec/pixel/pixel] = Blanks	
116	1655 - 1670	A16	Spare = Blanks (fixed value)	Copy the value of Level 1.1
117	1671 - 1678	A8	Line content indicator = 'OTHERbbb'	
118	1679 - 1682	A4	Clutter lock applied flag = 'YESb', 'NO..bb'	Copy the value of Level 1.1
119	1683 - 1686	A4	Auto-focusing applied flag = 'YESb', 'NO..bb'	Copy the value of Level 1.1

**Table 3-10 Data set summary records (9/12)**

Field No.	Byte No.	Type	Description	Remarks
120	1687 - 1702	F16.7	Line spacing [m] Spotlight: 0.625/ 1.25/ 2.5 Ultra-fine: 2.5/ 5.0/ 10.0 High-sensitive: 3.125/ 6.25/ 12.5 Fine: 6.25/ 12.5 ScanSAR: 25.0/ 50.0/ 100.0	The pixel spacing is not defined as the value on a reference ellipsoid but as the value on a map coordinates.
121	1703 - 1718	F16.7	Pixel spacing [m] Spotlight: 0.625/ 1.25/ 2.5 Ultra-fine: 2.5/ 5.0/ 10.0 High-sensitive: 3.125/ 6.25/ 12.5 Fine: 6.25/ 12.5 ScanSAR: 25.0/ 50.0/ 100.0	The pixel spacing is not defined as the value on a reference ellipsoid but as the value on a map coordinates.
122	1719 - 1734	A16	Processor range compression designator = 'EXTRACTEDbCHIRPb'	Copy the value of Level 1.1
123	1735 - 1750	F16.7	Doppler center frequency approximately coefficient constant term (a)	$fd = a + b \cdot R$
124	1751 - 1766	F16.7	Doppler center frequency approximately linear coefficient term (b)	fd: Doppler center frequency [Hz] R: Slant range [km] Copy the value of Level 1.1

**Table 3-10 Data set summary records (10/12)**

Field No.	Byte No.	Type	Description	Remarks
			<b>SENSOR SPECIFIC LOCAL USE SEGMENT</b>	
125	1767 - 1770	I4	Calibration mode data location flag No calibration data = 'bbb0' The side of observation start = 'bbb1' The side of observation end = 'bbb2' The side of observation start/end = 'bbb3'	Copy the value of Level 1.1
126	1771 - 1778	I8	Start line number of calibration at the side of start In case of calibration location flag is '0', always = 'bbbbbbb0'	Copy the value of Level 1.1
127	1779 - 1786	I8	End line number of calibration at the side of start In case of calibration location flag is '0', always = 'bbbbbbb0'	Copy the value of Level 1.1
128	1787 - 1794	I8	Start line number of calibration at the side of end In case of calibration location flag is '0', always = 'bbbbbbb0'	Copy the value of Level 1.1
129	1795 - 1802	I8	End line number of calibration at the side of end In case of calibration location flag is '0', always = 'bbbbbbb0'	Copy the value of Level 1.1
130	1803 - 1806	I4	PRF switching indicator A fixed PRF 1 scene = 'bbb0' Variable PRFs = 'bbb1' ScanSAR mode = 'bbb1'	Copy the value of Level 1.1
131	1807 - 1814	I8	Line number of PRF switching A fixed PRF = 'bbbbbbb1' ScanSAR mode = 'bbbbbbb0'	Copy the value of Level 1.1
132	1815 - 1830	F16.7	The direction of a beam center in a scene center [deg] = Blanks	
133	1831 - 1834	I4	Yaw steering mode flag No yaw steering mode = 'bbb1' Yaw steering mode = 'bbb0'	Copy the value of Level 1.1
134	1835 - 1838	I4	Parameter table number of automatically setting = 'bbbb'	Copy the value of Level 1.1
135	1839 - 1854	F16.7	Nominal off nadir angle	Copy the value of Level 1.1
136	1855 - 1858	I4	Antenna beam number	Copy the value of Level 1.1
137	1859 - 1886	A28	Spare = Blanks	Copy the value of Level 1.1

**Table 3-10 Data set summary records (11/12)**

Field No.	Byte No.	Type	Description	Remarks
			PROCESSING SPECIFIC LOCAL USE SEGMENT	
138	1887 - 1906	E20.13	Incidence angle constant term (a0) = Blanks	$\theta = a_0 + a_1 * R + a_2 * R^2 + a_3 * R^3 + a_4 * R^4 + a_5 * R^5$ $\theta$ : Incidence angle [rad] R: Slant range [km]
139	1907 - 1926	E20.13	Incidence angle linear coefficient term (a1) = Blanks	
140	1927 - 1946	E20.13	Incidence angle quadratic coefficient term (a2) = Blanks	
141	1947 - 1966	E20.13	Incidence angle cubic coefficient term (a3) = Blanks	
142	1967 - 1986	E20.13	Incidence angle fourth coefficient term (a4) = Blanks	
143	1987 - 2006	E20.13	Incidence angle fifth coefficient term (a5) = Blanks	

**Table 3-10 Data set summary records (12/12)**

Field No.	Byte No.	Type	Description	Remarks
			IMAGE ANNOTATION SEGMENT	
144	2007 - 2014	I8	Number of annotation points (up to 64) = 'bbbbbbb0'	Copy the value of Level 1.1
145	2015 - 2022	A8	Spare = Blanks	Copy the value of Level 1.1
146	2023 - 2030	I8	Line number of 1 <sup>st</sup> annotation start = Blanks	Copy the value of Level 1.1
147	2031 - 2038	I8	Pixel number of 1 <sup>st</sup> annotation start = Blanks	Copy the value of Level 1.1
148	2039 - 2054	A16	1 <sup>st</sup> annotation text = Blanks	Copy the value of Level 1.1
149	2055 - 2062	I8	Line number of 2 <sup>nd</sup> annotation start = Blanks	Copy the value of Level 1.1
150	2063 - 2070	I8	Pixel number of 2 <sup>nd</sup> annotation start = Blanks	Copy the value of Level 1.1
151	2071 - 2086	A16	2 <sup>nd</sup> annotation text = Blanks	Copy the value of Level 1.1
	.		.	.
	.		.	.
	.		.	.
152	4039 - 4046	I8	Line number of 64 <sup>th</sup> annotation start = Blanks	Copy the value of Level 1.1
153	4047 - 4054	I8	Pixel number of 64 <sup>th</sup> annotation start = Blanks	Copy the value of Level 1.1
154	4055 - 4070	A16	64 <sup>th</sup> annotation text = Blanks	Copy the value of Level 1.1
155	4071 - 4096	A26	System reserve = Blanks	Copy the value of Level 1.1

**Table 3-11 Map projection data records (1/4)**

Field No.	Byte No.	Type	Description	Remarks
1	1 - 4	B4	Record number = 3) <sub>10</sub>	
2	5 - 5	B1	1 <sup>st</sup> record sub-type code = 18) <sub>10</sub>	
3	6 - 6	B1	Record type code = 20) <sub>10</sub>	
4	7 - 7	B1	2 <sup>nd</sup> record sub-type code = 18) <sub>10</sub>	
5	8 - 8	B1	3 <sup>rd</sup> record sub-type code = 20) <sub>10</sub>	
6	9 - 12	B4	Map projection data record length = 1620) <sub>10</sub>	
7	13 - 28	A16	Blanks	
<b>MAP PROJECTION GENERAL INFORMATION</b>				
8	29 - 60	A32	Map projection = 'GEOCODEDbbbbbbbbbbbbbbbbbbbb'	
9	61 - 76	I16	Number of pixel per line	
10	77 - 92	I16	Number of lines	
11	93 - 108	F16.7	Inter-line distance in output scene [m] (Nominal value) Spotlight: 0.625/ 1.25/ 2.5 Ultra-fine: 2.5/ 5.0/ 10.0 High-sensitive: 3.125/ 6.25/ 12.5 Fine: 6.25/ 12.5 ScanSAR: 25.0/ 50.0/ 100.0	The inter-line/pixel distances is not defined as the value on a reference ellipsoid but as the value on a map coordinates.
12	109 - 124	F16.7	Inter-pixel distance in output scene [m] (Nominal value) Spotlight: 0.625/ 1.25/ 2.5 Ultra-fine: 2.5/ 5.0/ 10.0 High-sensitive: 3.125/ 6.25/ 12.5 Fine: 6.25/ 12.5 ScanSAR: 25.0/ 50.0/ 100.0	
13	125 - 140	F16.7	The angle between projection axis from true north at processed scene center [deg]	
14	141 - 156	F16.7	Actual platform orbital Inclination = 0.0000000	
15	157 - 172	F16.7	Actual ascending node = 0.0000000	
16	173 - 188	F16.7	Distance of platform at input scene center from the geocentric [m] = Blanks	
17	189 - 204	F16.7	Geodetic altitude of the platform relative to the ellipsoid [m] = Blanks	
18	205 - 220	F16.7	Actual ground speed at nadir at input scene center time [m/sec] = Blanks	
19	221 - 236	F16.7	Platform headings [deg] = Blanks	

C



**Table 3-11 Map projection data records (2/4)**

Field No.	Byte No.	Type	Description	Remarks
			<b>PROJECTION ELLIPSOID PARAMETERS</b>	
20	237 - 268	A32	Name of reference ellipsoid = 'GRS80bbbbbbbbbbbbbbbbbbbb'	
21	269 - 284	F16.7	Semi-major axis of referenced ellipsoid [m] = 6378137.0000000	
22	285 - 300	F16.7	Semi-minor axis of referenced ellipsoid [m] = 6356752.3141000	
23	301 - 316	F16.7	Datum shift parameter (dx) [m] = 0.0000000	
24	317 - 332	F16.7	Datum shift parameter (dy) [m] = 0.0000000	
25	333 - 348	F16.7	Datum shift parameter (dz) [m] = 0.0000000	
26	349 - 364	F16.7	Datum shift (1 <sup>st</sup> rotation angle) = 0.0000000	
27	365 - 380	F16.7	Datum shift (2 <sup>nd</sup> rotation angle) = 0.0000000	
28	381 - 396	F16.7	Datum shift (3 <sup>rd</sup> rotation angle) = 0.0000000	
29	397 - 412	F16.7	Scale factor of referenced ellipsoid = 0.0000000	
			<b>MAP PROJECTION DESIGNATOR</b>	
30	413 - 444	A32	Alphanumeric description of map projection = 'UTM-PROJECTIONbbbbbbbbbbbbbbbb': UTM-projection = 'UPS-PROJECTIONbbbbbbbbbbbbbbbb': PS-projection = 'MER-PROJECTIONbbbbbbbbbbbbbbbb': Mercator-projection = 'LCC-PROJECTIONbbbbbbbbbbbbbbbb': LCC-projection	
			<b>UTM-PROJECTION (1<sup>st</sup> default)</b>	
31	445 - 476	A32	Type of UTM = 'UNIVERSALbTRANSVERSEbMERCATORbbb'	Blanks except UTM
32	477 - 480	A4	UTM zone number	
33	481 - 496	F16.5	Map origin (false easting) [m] = 500000.00000	
34	497 - 512	F16.5	Map origin (false northing)[m] = 0.00000: Northern Hemisphere = 1000000.00000: Southern Hemisphere	
35	513 - 528	F16.7	Center of projection longitude [deg]	
36	529 - 544	F16.7	Center of projection latitude [deg]	
37	545 - 560	A16	Blanks	
38	561 - 576	A16	Blanks	
39	577 - 592	F16.7	Scale factor = 0.9996000	
			<b>UPS-PROJECTION (2<sup>nd</sup> default)</b>	
40	593 - 624	A32	Type of UPS = 'UNIVERSALbPOLARbSTEREOGRAPHICbbb'	Blanks except UPS
41	625 - 640	F16.7	Center of projection longitude [deg]	
42	641 - 656	F16.7	Center of projection latitude [deg]	
43	657 - 672	F16.7	Scale factor = 1.0000000	

**Table 3-11 Map projection data records (3/4)**

Field No.	Byte No.	Type	Description	Remarks
			NATIONAL SYSTEM PROJECTION (any other)	
44	673 - 704	A32	Projection descriptor = 'MERCATORbbbbbbbbbbbbbbbbbbbb': MER-PROJECTION = 'LAMBERT-CONFORMALbCONICbbbbbbbb': LCC-PROJECTION	Blanks except MER and LCC
45	705 - 720	F16.5	Map origin (false easting) [m] = Blanks	
46	721 - 736	F16.5	Map origin (false northing) [m] = Blanks	
47	737 - 752	F16.7	Center of projection longitude [deg] (In either case MER/LCC, set center map origin lat/lon)	
48	753 - 768	F16.7	Center of projection latitude [deg] (In either case MER/LCC, set center map origin lat/lon)	
49	769 - 784	F16.7	Standard parallel [deg] (Standard parallel $\phi_1$ ) MER: 0.0 fixed, LCC: latitude of scene center	
50	785 - 800	F16.7	Standard parallel [deg] (Standard parallel $\phi_2$ ) MER: 0.0 fixed, LCC: latitude of scene center	
51	801 - 816	F16.7	Standard parallel [deg] = Blanks	
52	817 - 832	F16.7	Standard parallel [deg] = Blanks	
53	833 - 848	F16.7	Central meridian [deg] = Blanks	
54	849 - 864	F16.7	Central meridian [deg] = Blanks	
55	865 - 880	F16.7	Central meridian [deg] = Blanks	
56	881 - 944	A64	Blanks	

**Table 3-11 Map projection data records (4/4)**

Field No.	Byte No.	Type	Description	Remarks
			<b>COORDINATES OF FOUR CORNER POINTS</b>	
57	945 - 960	F16.7	Top left corner northing [km]	Set the X coordinate value at the center of pixel at the top left corner
58	961 - 976	F16.7	Top left corner easting [km]	Set the Y coordinate value at the center of pixel at the top left corner
59	977 - 992	F16.7	Top right corner northing [km]	Set the X coordinate value at the center of pixel at the top right corner
60	993 - 1008	F16.7	Top right corner easting [km]	Set the Y coordinate value at the center of pixel at the top right corner
61	1009 - 1024	F16.7	Bottom right corner northing [km]	Set the X coordinate value at the center of pixel at the bottom right corner
62	1025 - 1040	F16.7	Bottom right corner easting [km]	Set the Y coordinate value at the center of pixel at the bottom right corner
63	1041 - 1056	F16.7	Bottom left corner northing [km]	Set the X coordinate value at the center of pixel at the bottom left corner
64	1057 - 1072	F16.7	Bottom left corner easting [km]	Set the Y coordinate value at the center of pixel at the bottom left corner
65	1073 - 1088	F16.7	Top left corner latitude [deg]	Set latitude at the center of pixel at the top left corner
66	1089 - 1104	F16.7	Top left corner longitude [deg]	Set longitude at the center of pixel at the top left corner
67	1105 - 1120	F16.7	Top right corner latitude [deg]	Set latitude at the center of pixel at the top right corner
68	1121 - 1136	F16.7	Top right corner longitude [deg]	Set longitude at the center of pixel at the top right corner
69	1137 - 1152	F16.7	Bottom right corner latitude [deg]	Set latitude at the center of pixel at the bottom right corner
70	1153 - 1168	F16.7	Bottom right corner longitude [deg]	Set longitude at the center of pixel at the bottom right corner
71	1169 - 1184	F16.7	Bottom left corner latitude [deg]	Set latitude at the center of pixel at the bottom left corner
72	1185 - 1200	F16.7	Bottom left corner longitude [deg]	Set longitude at the center of pixel at the bottom left corner
73	1201 - 1216	A16	Top left corner terrain height relative to ellipsoid [m] = Blanks	
74	1217 - 1232	A16	Top right corner terrain height relative to ellipsoid [m] = Blanks	
75	1233 - 1248	A16	Bottom right corner terrain height relative to ellipsoid [m] = Blanks	
76	1249 - 1264	A16	Bottom left corner terrain height relative to ellipsoid [m] = Blanks	
77	1265 - 1424	8E20.10	<p>Eight coefficients to convert a line(L) and pixel(P) position to the map projection frame of reference, say (E, N) where:</p> $E = A11 + A12*L + A13*P + A14*L*P$ $N = A21 + A22*L + A23*P + A24*L*P$ <p>The order of storing: A11, A12, A13, ..., A24                      Recommend to use the coefficients of 1025-2024 bytes in facility related data record 5</p>	<p>For the expressions, the position defined as (P, L) = (1, 1). corresponds to the central point of the pixel at the upper left corner and (E, N) show a longitude [deg] and a latitude [deg.].</p>
78	1425 - 1584	8E20.10	<p>Eight coefficients to convert from the map projection (E, N) to line(L) and pixel(P) position in the image, say (L, P) where:</p> $L = B11 + B12*E + B13*N + B14*E*N$ $P = B21 + B22*E + B23*N + B24*E*N$ <p>The order of storing: B11, B12, B13, ..., B24                      Recommend to use the coefficients of 2065-3064 bytes in facility related data record 5</p>	
79	1585 - 1620	A36	Blanks	

**Table 3-12 Platform position data records (1/2)**

Field No.	Byte No.	Type	Description	Remarks
1	1 - 4	B4	Record number = 4) <sub>10</sub>	
2	5 - 5	B1	1 <sup>st</sup> record sub-type code = 18) <sub>10</sub>	Copy the value of Level 1.1
3	6 - 6	B1	Record type code = 30) <sub>10</sub>	Copy the value of Level 1.1
4	7 - 7	B1	2 <sup>nd</sup> record sub-type code = 18) <sub>10</sub>	Copy the value of Level 1.1
5	8 - 8	B1	3 <sup>rd</sup> record sub-type code = 20) <sub>10</sub>	Copy the value of Level 1.1
6	9 - 12	B4	Platform position data record length = 4680) <sub>10</sub>	Copy the value of Level 1.1
7	13 - 44	A32	Orbital elements designator Orbit information (preliminary) = '0bbbbbbbbbbbbbbbbbbbbbbbbbbbb' Orbit information (decision) = '1bbbbbbbbbbbbbbbbbbbbbbbbbbbb' High precision orbit information = '2bbbbbbbbbbbbbbbbbbbbbbbbbbbb'	Copy the value of Level 1.1
8	45 - 60	F16.7	1 <sup>st</sup> orbital element Position vector in the earth fixed coordinate system of the scene center (x) [m]	Copy the value of Level 1.1
9	61 - 76	F16.7	2 <sup>nd</sup> orbital element Position vector in the earth fixed coordinate system of the scene center (y) [m]	Copy the value of Level 1.1
10	77 - 92	F16.7	3 <sup>rd</sup> orbital element Position vector in the earth fixed coordinate system of the scene center (z) [m]	Copy the value of Level 1.1
11	93 - 108	F16.7	4 <sup>th</sup> orbital element Velocity vector in the earth fixed coordinate system of the scene center (x') [m/sec]	Copy the value of Level 1.1
12	109 - 124	F16.7	5 <sup>th</sup> orbital element Velocity vector in the earth fixed coordinate system of the scene center (y') [m/sec]	Copy the value of Level 1.1
13	125 - 140	F16.7	6 <sup>th</sup> orbital element Velocity vector in the earth fixed coordinate system of the scene center (z') [m/sec]	Copy the value of Level 1.1
14	141 - 144	I4	Number of data points Orbit information (preliminary) = 'bb28' Orbit information (decision) = 'bb28' High precision orbit information = 'bb28'	Copy the value of Level 1.1
15	145 - 148	I4	YYYY : Year of 1 <sup>st</sup> point	Copy the value of Level 1.1
16	149 - 152	I4	bbMM : Month of 1 <sup>st</sup> point	Copy the value of Level 1.1

B

B

B

**Table 3-12 Platform position data records (2/2)**

Field No.	Byte No.	Type	Description	Remarks
17	153 - 156	I4	bbDD : Day of 1 <sup>st</sup> point	Copy the value of Level 1.1
18	157 - 160	I4	Day in the year of 1 <sup>st</sup> point (Ex: 2 <sup>nd</sup> February = 33 <sup>th</sup> )	Copy the value of Level 1.1
19	161 - 182	E22.15	Seconds of day of 1 <sup>st</sup> point (Ex: 0:51:30.23 = 3090.23)	Copy the value of Level 1.1
20	183 - 204	E22.15	Time interval between data points [sec] = 60	Copy the value of Level 1.1
21	205 - 268	A64	Reference co-ordinate system (ECI, ECR) = 'ECRbb'	Copy the value of Level 1.1
22	269 - 290	E22.15	Greenwich mean hour angle [deg] = Blanks (fixed value)	Copy the value of Level 1.1
23	291 - 306	F16.7	Along track position error [m] = Nominal value	Copy the value of Level 1.1
24	307 - 322	F16.7	Across track position error [m] = Nominal value	Copy the value of Level 1.1
25	323 - 338	F16.7	Radial position error [m] = Nominal value	Copy the value of Level 1.1
26	339 - 354	F16.7	Along track velocity error [m/sec] = Nominal value	Copy the value of Level 1.1
27	355 - 370	F16.7	Across track velocity error [m/sec] = Nominal value	Copy the value of Level 1.1
28	371 - 386	F16.7	Radial velocity error [m/sec] = Nominal value	Copy the value of Level 1.1
			<b>FIRST POSITIONAL DATA POINT</b>	Copy the value of Level 1.1
29	387 - 408	E22.15	1 <sup>st</sup> data point position vector (x) [m]	Copy the value of Level 1.1
30	409 - 430	E22.15	1 <sup>st</sup> data point position vector (y) [m]	Copy the value of Level 1.1
31	431 - 452	E22.15	1 <sup>st</sup> data point position vector (z) [m]	Copy the value of Level 1.1
32	453 - 474	E22.15	1 <sup>st</sup> data point position vector (x') [m/sec]	Copy the value of Level 1.1
33	475 - 496	E22.15	1 <sup>st</sup> data point position vector (y') [m/sec]	Copy the value of Level 1.1
34	497 - 518	E22.15	1 <sup>st</sup> data point position vector (z') [m/sec]	Copy the value of Level 1.1
	519 - 4082	27*6* E22.15	Repeat 2 <sup>nd</sup> - 28 <sup>th</sup> data point same as 387-518 bytes	Copy the value of Level 1.1
35	4083 - 4100	A18	Blanks	Copy the value of Level 1.1
36	4101 - 4101	I1	Occurrence flag of a leap second No leap second = '0' Occurrence of a leap second = '1'	Copy the value of Level 1.1
37	4102 - 4680	A579	Blanks	Copy the value of Level 1.1

**Table 3-13 Attitude data records (1/2)**

Field No.	Byte No.	Type	Description	Remarks
1	1 - 4	B4	Record number = 5) <sub>10</sub>	
2	5 - 5	B1	1 <sup>st</sup> record sub-type code = 18) <sub>10</sub>	Copy the value of Level 1.1
3	6 - 6	B1	Record type code = 40) <sub>10</sub>	Copy the value of Level 1.1
4	7 - 7	B1	2 <sup>nd</sup> record sub-type code = 18) <sub>10</sub>	Copy the value of Level 1.1
5	8 - 8	B1	3 <sup>rd</sup> record sub-type code = 20) <sub>10</sub>	Copy the value of Level 1.1
6	9 - 12	B4	Attitude data records length = 16384) <sub>10</sub>	Copy the value of Level 1.1
7	13 - 16	I4	Number of points = 'bb22': Except ScanSAR mode = 'bb62': ScanSAR mode	Copy the value of Level 1.1
8	17 - 20	I4	Day of the year	Copy the value of Level 1.1
9	21 - 28	I8	Mil li-second of the day = 'bbbbbb0'~'8639999'	Copy the value of Level 1.1
10	29 - 32	I4	Pitch data quality flag Good (within limit check) = 'bbb0' NG (out of limit check) = 'bbb1'	Copy the value of Level 1.1
11	33 - 36	I4	Roll data quality flag Good (within limit check) = 'bbb0' NG (out of limit check) = 'bbb1'	Copy the value of Level 1.1
12	37 - 40	I4	Yaw data quality flag Good (within limit check) = 'bbb0' NG (out of limit check) = 'bbb1'	Copy the value of Level 1.1
13	41 - 54	E14.6	Pitch [deg]	Copy the value of Level 1.1
14	55 - 68	E14.6	Roll [deg]	Copy the value of Level 1.1
15	69 - 82	E14.6	Yaw [deg]	Copy the value of Level 1.1

**Table 3-13 Attitude data records (2/2)**

Field No.	Byte No.	Type	Description	Remarks
16	83 - 86	I4	Pitch rate quality flag Good (within limit check) = 'bbb0' NG (out of limit check) = 'bbb1'	Copy the value of Level 1.1
17	87 - 90	I4	Roll rate quality flag Good (within limit check) = 'bbb0' NG (out of limit check) = 'bbb1'	Copy the value of Level 1.1
18	91 - 94	I4	Yaw rate quality flag Good (within limit check) = 'bbb0' NG (out of limit check) = 'bbb1'	Copy the value of Level 1.1
19	95 - 108	E14.6	Pitch rate	Copy the value of Level 1.1
20	109 - 122	E14.6	Roll rate	Copy the value of Level 1.1
21	123 - 136	E14.6	Yaw rate	Copy the value of Level 1.1
	137 - 136+120*(n-1)	120*(n-1)	Repeat bytes 17-136 for the number of points (n ) in section 7	Copy the value of Level 1.1
22	137+120*(n-1) - 16384	A(16384- (136+120 *(n-1)))	Blanks	Copy the value of Level 1.1

**Table 3-14 Radiometric data records (1/2)**

Field No.	Byte No.	Type	Description	Remarks
1	1 - 4	B4	Record number = 6) <sub>10</sub>	
2	5 - 5	B1	1 <sup>st</sup> record sub-type code = 18) <sub>10</sub>	Copy the value of Level 1.1
3	6 - 6	B1	Record type code = 50) <sub>10</sub>	Copy the value of Level 1.1
4	7 - 7	B1	2 <sup>nd</sup> sub-type code = 18) <sub>10</sub>	Copy the value of Level 1.1
5	8 - 8	B1	3 <sup>rd</sup> sub-type code = 20) <sub>10</sub>	Copy the value of Level 1.1
6	9 - 12	B4	Radiometric data record length = 9860) <sub>10</sub>	Copy the value of Level 1.1
7	13 - 16	I4	Radiometric data records sequence number = 'bbb1'	Copy the value of Level 1.1
8	17 - 20	I4	Number of radiometric fields = 'bbb1'	Copy the value of Level 1.1
<b>RADIOMETRIC DATA SET</b>				
9	21 - 36	F16.7	Calibration factor (CF) $\sigma^0 = 10 * \log_{10} \langle DN^2 \rangle + CF$ This means that the sigma-naught of a pixel can be obtained by the ensemble averaging ( $\langle \rangle$ ), i.e., the spatial averaging of pixel values around the target. Here, DN in $\langle \rangle$ of the above formula is the pixel values in levels 2.1.	
10	37 - 52	F16.7	Transmission distortion matrix for High-sensitive/Fine modes (Full (Quad.) pol.) level 1.1 (DT) (*) Real part of DT(1, 1)	Copy the value of Level 1.1
11	53 - 68	F16.7	Imaginary part of DT(1, 1)	Copy the value of Level 1.1
12	69 - 84	F16.7	Real part of DT(1, 2)	Copy the value of Level 1.1
13	85 - 100	F16.7	Imaginary part of DT(1, 2)	Copy the value of Level 1.1
14	101 - 116	F16.7	Real part of DT(2, 1)	Copy the value of Level 1.1
15	117 - 132	F16.7	Imaginary part of DT(2, 1)	Copy the value of Level 1.1
16	133 - 148	F16.7	Real part of DT(2, 2)	Copy the value of Level 1.1
17	149 - 164	F16.7	Imaginary part of DT(2, 2)	Copy the value of Level 1.1
18	165 - 180	F16.7	Reception distortion matrix for High-sensitive/Fine modes (Full (Quad.) pol.) level 1.1 (DR) (*) Real part of DR(1, 1)	Copy the value of Level 1.1
19	181 - 196	F16.7	Imaginary part of DR(1, 1)	Copy the value of Level 1.1



**Table 3-14 Radiometric data records (2/2)**

Field No.	Byte No.	Type	Description	Remarks
20	197 - 212	F16.7	Real part of DR(1, 2)	Copy the value of Level 1.1
21	213 - 228	F16.7	Imaginary part of DR(1, 2)	Copy the value of Level 1.1
22	229 - 244	F16.7	Real part of DR(2, 1)	Copy the value of Level 1.1
23	245 - 260	F16.7	Imaginary part of DR(2, 1)	Copy the value of Level 1.1
24	261 - 276	F16.7	Real part of DR(2, 2)	Copy the value of Level 1.1
25	277 - 292	F16.7	Imaginary part of DR(2, 2)	Copy the value of Level 1.1
26	293 - 9860	A9568	Reserve (Blanks)	Copy the value of Level 1.1

(\*)Notes:

The measured scattering matrix can be expressed by

$$\begin{pmatrix} Z_{hh} & Z_{hv} \\ Z_{vh} & Z_{vv} \end{pmatrix} = A \frac{1}{r} \exp\left(-\frac{4\pi r}{\lambda} j\right) \begin{pmatrix} 1 & \delta_3 \\ \delta_4 & f_2 \end{pmatrix} \begin{pmatrix} S_{hh} & S_{hv} \\ S_{vh} & S_{vv} \end{pmatrix} \begin{pmatrix} 1 & \delta_1 \\ \delta_2 & f_1 \end{pmatrix} + \begin{pmatrix} N_{hh} & N_{hv} \\ N_{vh} & N_{vv} \end{pmatrix}$$

where  $Z_{ij}$  is the measurement matrix of the target,  $j$  is the transmission polarization,  $i$  is the reception polarization,  $A$  is the amplitude,  $r$  is the slant range,  $S_{ij}$  is the true scattering matrix of the target,  $f_1$  is the channel imbalance of the transmission distortion matrix,  $f_2$  is that for the reception matrix,  $\delta_1$  and  $\delta_2$  are the cross talks of transmission, and  $\delta_3$  and  $\delta_4$  are the those for the reception,  $N_{ij}$  are the noise component. Here,  $N_{ij}$  is assumed to be zero. It should be noted that polarization notation of the product is different from the above, i.e., IMG-HV-ALPSR..., means the data acquired at H transmission and V reception.

Complex transmission distortion matrix ( $1, \delta_1, \delta_2, f_1$ ) are stored from 37 to 164 bytes, and reception distortion matrix ( $1, \delta_3, \delta_4, f_2$ ) are stored from 165 to 292 bytes.

Calibration factor is stored from 21 to 36 bytes.

**Table 3-15 Data quality summary records (1/2)**

Field No.	Byte No.	Type	Description	Remarks
1	1 - 4	B4	Record number = 7) <sub>10</sub>	
2	5 - 5	B1	1 <sup>st</sup> record sub-type code = 18) <sub>10</sub>	Copy the value of Level 1.1
3	6 - 6	B1	Record type code = 60) <sub>10</sub>	Copy the value of Level 1.1
4	7 - 7	B1	2 <sup>nd</sup> record sub-type code = 18) <sub>10</sub>	Copy the value of Level 1.1
5	8 - 8	B1	3 <sup>rd</sup> record sub-type code = 20) <sub>10</sub>	Copy the value of Level 1.1
6	9 - 12	B4	Data quality summary record length = 1620) <sub>10</sub>	Copy the value of Level 1.1
7	13 - 16	I4	Data quality summary record number = 'bbb1'	Copy the value of Level 1.1
8	17 - 20	A4	SAR channel ID = 'ABCb' A: Reception of polarization (H, V) B: Reception antenna (S: Single beam, F: F-system, R: R-system) C : I, Q	Describe the channel that is the radiometric standard of channels used in observation. Copy the value of Level 1.1
9	21 - 26	A6	Date of the last calibration update = 'YYMMDD' YY : last two figure of the year MM : Month DD : Day	Copy the value of Level 1.1
10	27 - 30	A4	Number of channels (up to 8)	Copy the value of Level 1.1
<b>ABSOLUTE RADIOMETRIC DATA QUALITY</b>				
11	31 - 46	F16.7	ISLR (nominal value) [dB]	Copy the value of Level 1.1
12	47 - 62	F16.7	PSLR (nominal value) [dB]	Copy the value of Level 1.1
13	63 - 78	F16.7	Azimuth ambiguity rate (AAR) (Nominal value)	Copy the value of Level 1.1
14	79 - 94	F16.7	Range ambiguity rate (RAR) (Nominal value)	Copy the value of Level 1.1
15	95 - 110	F16.7	Estimate of SNR [dB]	Copy the value of Level 1.1
16	111 - 126	F16.7	BER (Actual value)	Copy the value of Level 1.1
17	127 - 142	F16.7	Slant range resolution (Nominal value) [m]	Copy the value of Level 1.1
18	143 - 158	F16.7	Azimuth resolution (Nominal value) [m]	Copy the value of Level 1.1
19	159 - 174	F16.7	Radiometric resolution (Nominal value) [dB]	Copy the value of Level 1.1
20	175 - 190	F16.7	Instantaneous dynamic range [dB]	Copy the value of Level 1.1

**Table 3-15 Data quality summary records (2/2)**

Field No.	Byte No.	Type	Description	Remarks
21	191 - 206	F16.7	Nominal absolute radiometric calibration magnitude uncertainty of SAR channel indicated in bytes 17-20 [dB]	Copy the value of Level 1.1
22	207 - 222	F16.7	Nominal absolute radiometric calibration phase uncertainty of SAR channel indicated in bytes 17-20 [deg]	Copy the value of Level 1.1
<b>RELATIVE RADIOMETRIC QUALITY</b>				
23	223 - 238	F16.7	Nominal relative radiometric calibration magnitude uncertainty of SAR channel indicated in bytes 17-20 [dB]	Copy the value of Level 1.1
24	239 - 254	F16.7	Nominal relative radiometric calibration phase uncertainty of SAR channel indicated in bytes 17-20 [deg]	Copy the value of Level 1.1
25	255 - (n-1)*32+254	(n-1)*2F16.7	Repetition of bytes 223 - 254 for the remaining channels (up to 8 channels)	Copy the value of Level 1.1
26	(n-1)*32+255 - 734	A(480 -(n-1)*32)	Blanks	Copy the value of Level 1.1
<b>ABSOLUTE GEOMETRIC DATA QUALITY</b>				
26	735 - 750	F16.7	Absolute location error along track (Nominal value) [m]	Copy the value of Level 1.1
27	751 - 766	F16.7	Absolute location error cross track (Nominal value) [m]	Copy the value of Level 1.1
28	767 - 782	F16.7	Geometric distortion scale in line direction (Nominal value)	Copy the value of Level 1.1
29	783 - 798	F16.7	Geometric distortion scale in pixel direction (Nominal value)	Copy the value of Level 1.1
30	799 - 814	F16.7	Geometric distortion skew	Copy the value of Level 1.1
31	815 - 830	F16.7	Scene orientation error	Copy the value of Level 1.1
<b>RELATIVE GEOMETRIC DATA QUALITY</b>				
32	831 - 846	F16.7	Along track relative misregistration error of other channels versus SAR channel (bytes 17-20) [meters]	Copy the value of Level 1.1
33	847 - 862	F16.7	Cross track relative misregistration error of other channels versus SAR channel (bytes 17-20) [meters]	Copy the value of Level 1.1
34	863 - 1102	(n-1)*2F16.7	Repetition of bytes 831 - 862 for the other channels (up to 8 channels)	Copy the value of Level 1.1
35	1103 - 1620	A518	Blanks	Copy the value of Level 1.1

**Table 3-16 Facility related data records 1 - 4 (1/1)**

Field No.	Byte No.	Type	Description	Remarks
1	1 - 4	B4	Record sequence number Dummy data = 8) <sub>10</sub> Determined ephemeris = 9) <sub>10</sub> Time error information = 10) <sub>10</sub> Coordinate conversion information = 11) <sub>10</sub>	
2	5 - 5	B1	1 <sup>st</sup> record sub-type code = 18) <sub>10</sub>	Copy the value of Level 1.1
3	6 - 6	B1	Record type code = 200) <sub>10</sub>	Copy the value of Level 1.1
4	7 - 7	B1	2 <sup>nd</sup> record sub-type code = 18) <sub>10</sub>	Copy the value of Level 1.1
5	8 - 8	B1	3rd record sub-type code = 70) <sub>10</sub> CEOS = 20) <sub>10</sub> , CCRS = 36) <sub>10</sub> , ESA = 50) <sub>10</sub> , NASA = 60) <sub>10</sub> , JPL = 61) <sub>10</sub> JAXA = 70) <sub>10</sub> , DFVLR = 80) <sub>10</sub> , RAE = 90) <sub>10</sub> , TELESPAZIO = 10) <sub>10</sub> UNSPECIFIED = 18) <sub>10</sub> , etc.	Copy the value of Level 1.1
6	9 - 12	B4	Record length Dummy data = 325,000 Determined ephemeris = 511,000 Time error information = 3,072 Coordinate conversion information = 728,000	Copy the value of Level 1.1
7	13 - 16	I4	Facility related data record sequence number = 'bbbb1' - 'bbb4'	Copy the value of Level 1.1
8	17 - 66	A50	Blanks	Copy the value of Level 1.1
9	67 -		Set the following files which were used for level 1.0 processing, for each record. Dummy data Determined ephemeris Time error information Coordinate conversion information	Copy the value of Level 1.1

A

A

A

**Table 3-17 Facility related data records 5 (1/4)**

Field No.	Byte No.	Type	Description	Remarks
1	1 - 4	B4	Record sequence number = 12) <sub>10</sub>	
2	5 - 5	B1	1 <sup>st</sup> record sub-type code = 18) <sub>10</sub>	Copy the value of Level 1.1
3	6 - 6	B1	Record type code = 200) <sub>10</sub>	Copy the value of Level 1.1
4	7 - 7	B1	2 <sup>nd</sup> record sub-type code = 18) <sub>10</sub>	Copy the value of Level 1.1
5	8 - 8	B1	3 <sup>rd</sup> record sub-type code = 70) <sub>10</sub> CEOS = 20) <sub>10</sub> , CCRS = 36) <sub>10</sub> , ESA = 50) <sub>10</sub> , NASA = 60) <sub>10</sub> , JPL = 61) <sub>10</sub> JAXA = 70) <sub>10</sub> , DFVLR = 80) <sub>10</sub> , RAE = 90) <sub>10</sub> , TELESPAZIO = 10) <sub>10</sub> UNSPECIFIED = 18) <sub>10</sub> , etc.	Copy the value of Level 1.1
6	9 - 12	B4	Record length = 5000) <sub>10</sub>	Copy the value of Level 1.1
7	13 - 16	I4	Facility related data record number = 'bbb5'	
8	17 - 416	20E20.10	Twenty coefficients to convert from the map projection (E, N) to Line(L) and pixel (P) position in the image, say (P, L) where: $P = a_0 + a_1 * \varphi + a_2 * \lambda + a_3 * \varphi * \lambda + a_4 * \varphi^2 + a_5 * \lambda^2 + a_6 * \varphi^2 * \lambda + a_7 * \varphi * \lambda^2 + a_8 * \varphi^3 + a_9 * \lambda^3$ $L = b_0 + b_1 * \varphi + b_2 * \lambda + b_3 * \varphi * \lambda + b_4 * \varphi^2 + b_5 * \lambda^2 + b_6 * \varphi^2 * \lambda + b_7 * \varphi * \lambda^2 + b_8 * \varphi^3 + b_9 * \lambda^3$ Coefficients a <sub>0</sub> - a <sub>9</sub> and b <sub>0</sub> - b <sub>9</sub> (The order of storing a <sub>0</sub> , a <sub>1</sub> , a <sub>2</sub> , ..., a <sub>9</sub> and b <sub>0</sub> , b <sub>1</sub> , b <sub>2</sub> , ..., b <sub>9</sub> ) (Recommend to use the coefficients of 2065-3064 bytes)	For the expressions, the position defined as (P, L) = (1, 1). corresponds to the central point of the pixel at the upper left corner and (E, N) show a longitude [deg] and a latitude [deg]
9	417 - 420	I4	Calibration mode data location flag No calibration data = 'bbb0' The side of observation start = 'bbb1' The side of observation end = 'bbb2' The side of observation start/end = 'bbb3'	Copy the value of Level 1.1

A

**Table 3-17 Facility related data records 5 (2/4)**

Field No.	Byte No.	Type	Description	Remarks
10	421 - 428	I8	Start line number of calibration at upper image In case of no calibration data ('0'), always = 'bbbbbbb0'	Copy the value of Level 1.1
11	429 - 436	I8	End line number of calibration at upper image In case of no calibration data ('0'), always = 'bbbbbbb0'	Copy the value of Level 1.1
12	437 - 444	I8	Start line number of calibration at bottom image In case of no calibration data ('0'), always = 'bbbbbbb0'	Copy the value of Level 1.1
13	445 - 452	I8	Stop line number of calibration at bottom image In case of no calibration data ('0'), always = 'bbbbbbb0'	Copy the value of Level 1.1
14	453 - 456	I4	PRF switching flag No change in a scene = 'bbb0' (fixed value)	Copy the value of Level 1.1
15	457 - 464	I8	Start line number of PRF switching No change = 'bbbbbbb1' (fixed value)	Copy the value of Level 1.1
16	465 - 472	I8	Blanks	Copy the value of Level 1.1
17	473 - 480	I8	Number of loss lines (Level 1.0)	Copy the value of Level 1.1
18	481 - 488	I8	Number of loss lines (range for processing in Level 1.1)	Copy the value of Level 1.1
19	489 - 800	A312	Blanks	Copy the value of Level 1.1
20	801 - 1024	A224	System reserve	Copy the value of Level 1.1

**Table 3-17 Facility related data records 5 (3/4)**

Field No.	Byte No.	Type	Description	Remarks
21	1025 - 2024	50E20.10	<p>Coefficients of the 8th polynomial expression to convert from pixel (P) and line (L) to latitude (<math>\phi</math>) and longitude (<math>\lambda</math>), say (<math>\phi, \lambda</math>) where:</p> $\phi = a_0 * L^4 * P^4 + a_1 * L^3 * P^4 + a_2 * L^2 * P^4 + a_3 * L * P^4 + a_4 * P^4$ $+ a_5 * L^4 * P^3 + a_6 * L^3 * P^3 + a_7 * L^2 * P^3 + a_8 * L * P^3 + a_9 * P^3$ $+ a_{10} * L^4 * P^2 + a_{11} * L^3 * P^2 + a_{12} * L^2 * P^2 + a_{13} * L * P^2 + a_{14} * P^2$ $+ a_{15} * L^4 * P + a_{16} * L^3 * P + a_{17} * L^2 * P + a_{18} * L * P + a_{19} * P$ $+ a_{20} * L^4 + a_{21} * L^3 + a_{22} * L^2 + a_{23} * L + a_{24}$ $\lambda = b_0 * L^4 * P^4 + b_1 * L^3 * P^4 + b_2 * L^2 * P^4 + b_3 * L * P^4 + b_4 * P^4$ $+ b_5 * L^4 * P^3 + b_6 * L^3 * P^3 + b_7 * L^2 * P^3 + b_8 * L * P^3 + b_9 * P^3$ $+ b_{10} * L^4 * P^2 + b_{11} * L^3 * P^2 + b_{12} * L^2 * P^2 + b_{13} * L * P^2 + b_{14} * P^2$ $+ b_{15} * L^4 * P + b_{16} * L^3 * P + b_{17} * L^2 * P + b_{18} * L * P + b_{19} * P$ $+ b_{20} * L^4 + b_{21} * L^3 + b_{22} * L^2 + b_{23} * L + b_{24}$ <p>(The order of storing: <math>a_0, a_1, a_2, \dots, a_{24}</math> &amp; <math>b_0, b_1, b_2, \dots, b_{24}</math>)</p>	<p>(P, L) referred in the upper left pixel(p) and line (l) are substituted by the following expressions as  <math>P = p - P_0, L = l - L_0</math>,                      where (p, l) is an arbitrary coordinate address on the image.                      For the expressions above, the position defined as  <math>(p, l) = (0, 0)</math>                      corresponds to the central point of the pixel at the upper left corner and (<math>\phi, \lambda</math>) is measured in "degrees".</p>
22	2025 - 2044	E20.10	Origin Pixel ( $P_0$ ) 0.0 fixed	
23	2045 - 2064	E20.10	Origin Line ( $L_0$ ) 0.0 fixed	

**Table 3-17 Facility related data records 5 (4/4)**

Field No.	Byte No.	Type	Description	Remarks
24	2065 - 3064	50E20.10	<p>Coefficients of the 8th polynomial expression to convert from latitude (<math>\Phi</math>) and longitude (<math>\Lambda</math>) to pixel (p) and line (l), say (p, l) where:</p> $p = c_0 * \Lambda^4 * \Phi^4 + c_1 * \Lambda^3 * \Phi^4 + c_2 * \Lambda^2 * \Phi^4 + c_3 * \Lambda * \Phi^4 + c_4 * \Phi^4$ $+ c_5 * \Lambda^4 * \Phi^3 + c_6 * \Lambda^3 * \Phi^3 + c_7 * \Lambda^2 * \Phi^3 + c_8 * \Lambda * \Phi^3 + c_9 * \Phi^3$ $+ c_{10} * \Lambda^4 * \Phi^2 + c_{11} * \Lambda^3 * \Phi^2 + c_{12} * \Lambda^2 * \Phi^2 + c_{13} * \Lambda * \Phi^2 + c_{14} * \Phi^2$ $+ c_{15} * \Lambda^4 * \Phi + c_{16} * \Lambda^3 * \Phi + c_{17} * \Lambda^2 * \Phi + c_{18} * \Lambda * \Phi + c_{19} * \Phi$ $+ c_{20} * \Lambda^4 + c_{21} * \Lambda^3 + c_{22} * \Lambda^2 + c_{23} * \Lambda + c_{24}$ $l = d_0 * \Lambda^4 * \Phi^4 + d_1 * \Lambda^3 * \Phi^4 + d_2 * \Lambda^2 * \Phi^4 + d_3 * \Lambda * \Phi^4 + d_4 * \Phi^4$ $+ d_5 * \Lambda^4 * \Phi^3 + d_6 * \Lambda^3 * \Phi^3 + d_7 * \Lambda^2 * \Phi^3 + d_8 * \Lambda * \Phi^3 + d_9 * \Phi^3$ $+ d_{10} * \Lambda^4 * \Phi^2 + d_{11} * \Lambda^3 * \Phi^2 + d_{12} * \Lambda^2 * \Phi^2 + d_{13} * \Lambda * \Phi^2 + d_{14} * \Phi^2$ $+ d_{15} * \Lambda^4 * \Phi + d_{16} * \Lambda^3 * \Phi + d_{17} * \Lambda^2 * \Phi + d_{18} * \Lambda * \Phi + d_{19} * \Phi$ $+ d_{20} * \Lambda^4 + d_{21} * \Lambda^3 + d_{22} * \Lambda^2 + d_{23} * \Lambda + d_{24}$ <p>(The order of storing: <math>c_0, c_1, c_2, \dots, c_{24}</math> &amp; <math>d_0, d_1, d_2, \dots, d_{24}</math>)</p>	<p>(<math>\Phi, \Lambda</math>) referred in the upper left latitude(<math>\phi</math>), longitude(<math>\lambda</math>) are substituted by the following expressions as  <math>F=f-F_0</math> (degrees),  <math>L=l-L_0</math> (degrees),                      where (f, l) is an arbitrary position on the image.                      For the expressions, the position defined as  <math>(p, l)=(0, 0)</math>                      corresponds to the central point of the pixel at the upper left corner.</p>
25	3065 - 3084	E20.10	Origin Latitude ( $\Phi_0$ ) scene center latitude	
26	3085 - 3104	E20.10	Origin Longitude ( $\Lambda_0$ ) scene center longitude	
27	3105 - 5000	A1896	Blanks	



**Table 3-18 SAR Image file descriptor records (1/4)**

Field No.	Byte No.	Type	Description	Remarks
1	1 - 4	B4	Record number = 1) <sub>10</sub>	Copy the value of Level 1.1
2	5 - 5	B1	1 <sup>st</sup> record sub-type code = 50) <sub>10</sub>	Copy the value of Level 1.1
3	6 - 6	B1	Record type code = 192) <sub>10</sub>	Copy the value of Level 1.1
4	7 - 7	B1	2 <sup>nd</sup> record sub-type code = 18) <sub>10</sub>	Copy the value of Level 1.1
5	8 - 8	B1	3 <sup>rd</sup> record sub-type code = 18) <sub>10</sub>	Copy the value of Level 1.1
6	9 - 12	B4	Record length = 720) <sub>10</sub>	Copy the value of Level 1.1
7	13 - 14	A2	ASCII/EBCDIC flag = 'Ab': ASCII	Copy the value of Level 1.1
8	15 - 16	A2	Blanks	Copy the value of Level 1.1
9	17 - 28	A12	Format control document ID = 'CEOS-SARbbbb'	Copy the value of Level 1.1
10	29 - 30	A2	Format control document revision level = 'bA'	Copy the value of Level 1.1
11	31 - 32	A2	File design descriptor revision letter = 'bA'	Copy the value of Level 1.1
12	33 - 44	A12	Software release and revision level = 'NNN.NNNbbbbbb' 001.000, 001.001, ... 001.100, ...002.000	
13	45 - 48	I4	File number = 'bbb1'	Copy the value of Level 1.1
14	49 - 64	A16	File ID = 'MMNbSSSTFFFFbbbb' MM: Mission ID (ALOS2='AL')(*) N: Mission number(='2')(*) SSS: Sensor ID (SAR='SAR')(*) T: Processing level code Level 2.1 = 'E' FFFF : File Type(*) Leader file = 'SARL' Image file = 'IMOP' Trailer file = 'SART'	(*)Copy the value of Level 1.1
15	65 - 68	A4	Record sequence and location type flag = 'FSEQ'	Copy the value of Level 1.1
16	69 - 76	I8	Location sequence number = 'bbbbbb1'	Copy the value of Level 1.1
17	77 - 80	I4	Field length of sequence number = 'bbb4'	Copy the value of Level 1.1

A

**Table 3-18 SAR Image file descriptor records (2/4)**

Field No.	Byte No.	Type	Description	Remarks
18	81 - 84	A4	Record code and location type flag = 'FTYP'	Copy the value of Level 1.1
19	85 - 92	I8	Record code location = 'bbbbbb5'	Copy the value of Level 1.1
20	93 - 96	I4	Record code field length = 'bbb4'	Copy the value of Level 1.1
21	97 - 100	A4	Record length and location type flag = 'FLGT'	Copy the value of Level 1.1
22	101 - 108	I8	Record length location = 'bbbbbb9'	Copy the value of Level 1.1
23	109 - 112	I4	Record length field length = 'bbb4'	Copy the value of Level 1.1
24	113 - 113	A1	Reserved = Blanks	Copy the value of Level 1.1
25	114 - 114	A1	Reserved = Blanks	Copy the value of Level 1.1
26	115 - 115	A1	Reserved = Blanks	Copy the value of Level 1.1
27	116 - 116	A1	Reserved = Blanks	Copy the value of Level 1.1
28	117 - 180	A64	Reserved = Blanks	Copy the value of Level 1.1
29	181 - 186	I6	Number of SAR data records Number of signal data records	Number of actual records
30	187 - 192	I6	SAR data record length	Actual record length
31	193 - 216	A24	Reserved = Blanks	Copy the value of Level 1.1

A

**Table 3-18 SAR Image file descriptor records (3/4)**

Field No.	Byte No.	Type	Description	Remarks
			<b>SAMPLE GROUP DATA</b>	
32	217 - 220	I4	Bit length per sample = 'bb16'	
33	221 - 224	I4	Number of samples per data group = 'bbb1'	
34	225 - 228	I4	Number of bytes per data group = 'bbb2'	
35	229 - 232	A4	Justification and order of samples within data group = Blanks(fixed value)	Copy the value of Level 1.1
			<b>SAR RELATED DATA IN THE RECORD</b>	
36	233 - 236	I4	Number of SAR channels = 'bbb1' (fixed value) (Only L-band)	Copy the value of Level 1.1
37	237 - 244	I8	Number of lines per data set (one channel) (Excluding border lines)	
38	245 - 248	I4	Number of left border pixels per line = 'bbb0'	Copy the value of Level 1.1
39	249 - 256	I8	Number of data group (or pixels) per line	
40	257 - 260	I4	Number of right border pixels per line = 'bbb0'	Copy the value of Level 1.1
41	261 - 264	I4	Number of top border lines = 'bbb0'	Copy the value of Level 1.1
42	265 - 268	I4	Number of bottom border lines = 'bbb0'	Copy the value of Level 1.1
43	269 - 272	A4	Interleaving ID = 'BSQb' (fixed value)	Copy the value of Level 1.1
			<b>RECORD DATA IN THE FILE</b>	
44	273 - 274	I2	Number of physical records per line = 'b1' (fixed value)	Copy the value of Level 1.1
45	275 - 276	I2	Number of physical records per multi-channel line in this file = 'b1' (fixed value)	Copy the value of Level 1.1
46	277 - 280	I4	Number of bytes of prefix data per record = 'b192'	
47	281 - 288	I8	Number of bytes of SAR data per record	
48	289 - 292	I4	Number of bytes of suffix data per record = 'bbb0' (fixed value)	Copy the value of Level 1.1
49	293 - 296	A4	Prefix/suffix repeat flag = 'bbbb' (fixed value)	Copy the value of Level 1.1

**Table 3-18 SAR Image file descriptor records (4/4)**

Field No.	Byte No.	Type	Description	Remarks
<b>PREFIX/SUFFIX DATA LOCATORS</b>				
50	297 - 304	A8	Sample data line number locator = 'bb13b4PB' 'P': Prefix, 'S': Suffix 'A': ASCII, 'B': Binary, 'N': Numeric	Copy the value of Level 1.1
51	305 - 312	A8	SAR channel number locator = 'bb49b2PB'	Copy the value of Level 1.1
52	313 - 320	A8	Time of SAR data line locator = 'bb45b4PB'	Copy the value of Level 1.1
53	321 - 328	A8	Left-fill count locator = 'bb21b4PB'	Copy the value of Level 1.1
54	329 - 336	A8	Right-fill count locator = 'bb29b4PB'	Copy the value of Level 1.1
55	337 - 340	A4	Pad pixels present indicator = 'bbbb'	Copy the value of Level 1.1
56	341 - 368	A28	Blanks	Copy the value of Level 1.1
57	369 - 376	A8	SAR data line quality code locator = 'bbbbbbbb'	
58	377 - 384	A8	Calibration information field locator = 'bbbbbbbb'	Copy the value of Level 1.1
59	385 - 392	A8	Gain values field locator = 'bbbbbbbb'	Copy the value of Level 1.1
60	393 - 400	A8	Bias values field locator = 'bbbbbbbb'	Copy the value of Level 1.1
61	401 - 428	A28	SAR data format type indicator = 'UNSIGNEDbINTEGER*2bbbbbbbb'	'UNSIGNEDbINTEGER*2bbbb bbbbbb'IU2b' : 2-bytes unsigned integer
62	429 - 432	A4	SAR data format type code = 'IU2b'	
63	433 - 436	I4	Number of left fill bits within pixel = 'bbb0'	Copy the value of Level 1.1
64	437 - 440	I4	Number of right fill bits within pixel = 'bbb0'	Copy the value of Level 1.1
65	441 - 448	I8	Maximum data range of pixel (starting from 0) = 'bbb65535'	
<b>SCANSAR BURST DATA INFORMATION</b>				
66	449 - 452	I4	Blanks	
67	453 - 456	I4	Blanks	
68	457 - 460	I4	Blanks	
69	461 - 720	A260	Blanks	

**Table 3-19 Processed data records (1/4)**

Field No.	Byte No.	Type	Description	Remarks
1	1 - 4	B4	Record sequence number = 2, 3, ...)10	
2	5 - 5	B1	1 <sup>st</sup> record sub-type code = 50)10	
3	6 - 6	B1	Record type code = 11)10	
4	7 - 7	B1	2 <sup>nd</sup> record sub-type code = 18)10	
5	8 - 8	B1	3 <sup>rd</sup> record sub-type code = 20)10	
6	9 - 12	B4	Record length	
<b>PREFIX DATA-GENERAL INFORMATION</b>				
7	13 - 16	B4	SAR image data line number = 1, 2, 3 ...)10	
8	17 - 20	B4	SAR image data record index = 1)10 (fixed value) (indicates the record sequence number in the same line)	
9	21 - 24	B4	Actual count of left-fill pixels = 0)10 (fixed value)	
10	25 - 28	B4	Actual count of data pixels	
11	29 - 32	B4	Actual count of right-fill pixels = 0)10	

**Table 3-19 Processed data records (2/4)**

Field No.	Byte No.	Type	Description	Remarks
			<b>PREFIX DATA-SENSOR PARAMETERS</b>	
12	33 - 36	B4	Sensor parameters update flag = 0) <sub>10</sub>	
13	37 - 40	B4	Sensor acquisition year	Copy the value of Level 1.1
14	41 - 44	B4	Sensor acquisition day of year	Copy the value of Level 1.1
15	45 - 48	B4	Sensor acquisition milliseconds of day = 0) <sub>10</sub>	
16	49 - 50	B2	SAR channel ID Single polarization = 1) <sub>10</sub> Dual polarization = 2) <sub>10</sub> Full (Quad.) pol. = 4) <sub>10</sub>	Copy the value of Level 1.1
17	51 - 52	B2	SAR channel code = 0) <sub>10</sub> L = 0) <sub>10</sub>	Copy the value of Level 1.1
18	53 - 54	B2	Transmitted polarization Horizontal polarization (H) = 0) <sub>10</sub> Vertical polarization (V) = 1) <sub>10</sub>	
19	55 - 56	B2	Received pulse polarization H = 0) <sub>10</sub> V = 1) <sub>10</sub>	
20	57 - 60	B4	PRF[mHz] Except ScanSAR mode = The same through the one scene ScanSAR = 0) <sub>10</sub> (fixed value)	
21	61 - 64	B4	Scan number = 0) <sub>10</sub> (fixed value)	

**Table 3-19 Processed data records (3/4)**

Field No.	Byte No.	Type	Description	Remarks
22	65 - 68	B4	Slant range to 1 <sup>st</sup> pixel [m]	
23	69 - 72	B4	Slant range to mid-pixel [m]	
24	73 - 76	B4	Slant range to last-pixel [m]	
25	77 - 80	B4	Doppler centroid value at 1 <sup>st</sup> pixel [1/1,000Hz]	
26	81 - 84	B4	Doppler centroid value at mid-pixel [1/1,000Hz]	
27	85 - 88	B4	Doppler centroid value at last pixel [1/1,000Hz]	
28	89 - 92	B4	Azimuth FM rate of 1 <sup>st</sup> pixel [Hz/msec]	
29	93 - 96	B4	Azimuth FM rate of mid-pixel [Hz/msec]	
30	97 - 100	B4	Azimuth FM rate of last pixel [Hz/msec]	
31	101 - 104	B4	Look angle of nadir [1/1,000,000 deg] = 0) <sub>10</sub>	
32	105 - 108	B4	Azimuth squint angle [1/1,000,000 deg] = 0) <sub>10</sub>	
33	109 - 128	B20	Blanks = 0) <sub>10</sub>	

**Table 3-19 Processed data records (4/4)**

Field No.	Byte No.	Type	Description	Remarks
			<b>PREFIX DATA-GEOGRAPHIC REFERENCE INFO.</b>	
34	129 – 132	B4	Geographic ref. Parameter update flag = 0) <sub>10</sub>	
35	133 - 136	B4	Latitude of 1 <sup>st</sup> pixel [1/1,000,000 deg]	
36	137 - 140	B4	Latitude of mid-pixel [1/1,000,000 deg]	The latitude at M/2th pixel is set. (M: number of pixels)
37	141 - 144	B4	Latitude of last pixel [1/1,000,000 deg]	
38	145 - 148	B4	Longitude of 1 <sup>st</sup> pixel [1/1,000,000 deg]	
39	149 – 152	B4	Longitude of mid-pixel [1/1,000,000 deg]	The longitude at M/2th pixel is set. (M: number of pixels)
40	153 – 156	B4	Longitude of last pixel [1/1,000,000 deg]	
41	157 - 160	B4	Northing of 1 <sup>st</sup> pixel [m]	Set X axis
42	161 – 164	B4	Blanks = 0) <sub>10</sub>	
43	165 – 168	B4	Northing of last pixel [m]	Set X axis
44	169 – 172	B4	Easting of 1 <sup>st</sup> pixel [m]	Set Y axis
45	173 – 176	B4	Blanks = 0) <sub>10</sub>	
46	177 – 180	B4	Easting of last pixel [m]	Set Y axis
47	181 - 184	B4	Line heading (orientation of the perpendicular to the data line center relative to true north) [1/1,000,000 deg] = 0) <sub>10</sub>	
48	185 – 192	B8	Blanks = 0) <sub>10</sub>	
			<b>SAR PROCESSED DATA</b>	
	193 - i	jBk	SAR processed data i: number of bytes of data + 192 j: number of pixels on this record k: size of pixel in bytes [2byte]	
			<b>SUFFIX DATA</b>	
		0*B	Processing Facility specific details	



**Table 3-20 SAR Trailer file descriptor (1/3)**

Field No.	Byte No.	Type	Description	Remarks
1	1 - 4	B4	Record number = 1) <sub>10</sub>	Copy the value of Level 1.1
2	5 - 5	B1	1 <sup>st</sup> record sub-type code = 63) <sub>10</sub>	Copy the value of Level 1.1
3	6 - 6	B1	Record type code = 192) <sub>10</sub>	Copy the value of Level 1.1
4	7 - 7	B1	2 <sup>nd</sup> record sub-type code = 18) <sub>10</sub>	Copy the value of Level 1.1
5	8 - 8	B1	3 <sup>rd</sup> record sub-type code = 18) <sub>10</sub>	Copy the value of Level 1.1
6	9 - 12	B4	Record length = 720) <sub>10</sub>	Copy the value of Level 1.1
7	13 - 14	A2	ASCII/EBCDIC code = 'Ab': ASCII	Copy the value of Level 1.1
8	15 - 16	A2	Blanks	Copy the value of Level 1.1
9	17 - 28	A12	Format control document ID = 'CEOS-SARbbbb'	Copy the value of Level 1.1
10	29 - 30	A2	Format control document revision number = 'bA'	Copy the value of Level 1.1
11	31 - 32	A2	Record format revision level = 'bA'	Copy the value of Level 1.1
12	33 - 44	A12	Software release and revision level = 'NNN.NNNbbbbbb' 001.000, 001.001, ... 001.100, ...002.000	
13	45 - 48	I4	Number of files = 'bbb1'	Copy the value of Level 1.1
14	49 - 64	A16	File ID = 'MMNbSSSTFFFFbbbb' MM: Mission ID(ALOS2='AL')(*) N: Mission number (=2')(*) SSS: Sensor ID (SAR='SAR')(*) T: Processing level code Level 2.1 = 'E' FFFF : Tile Type(*) Leader file = 'SARL' Image file = 'IMOP' Trailer file = 'SART'	(*)Copy the value of Level 1.1
15	65 - 68	A4	Record sequence and location type flag = 'FSEQ'	Copy the value of Level 1.1
16	69 - 76	I8	Sequence number location = 'bbbbbb1'	Copy the value of Level 1.1
17	77 - 80	I4	Sequence number field length = 'bbb4'	Copy the value of Level 1.1
18	81 - 84	A4	Record code and location type flag = 'FTYP'	Copy the value of Level 1.1
19	85 - 92	I8	Record code location = 'bbbbbb5'	Copy the value of Level 1.1
20	93 - 96	I4	Record code field length = 'bbb4'	Copy the value of Level 1.1

A

**Table 3-20 SAR Trailer file descriptor (2/3)**

Field No.	Byte No.	Type	Description	Remarks
21	97 - 100	A4	Record length and location type flag = 'FLGT'	Copy the value of Level 1.1
22	101 - 108	I8	Record length location = 'bbbbbb9'	Copy the value of Level 1.1
23	109 - 112	I4	Record length field length = 'bbb4'	Copy the value of Level 1.1
24	113 - 180	A68	Blanks	Copy the value of Level 1.1
25	181 - 186	I6	Number of data set summary records = 'bbbbbb0'	Copy the value of Level 1.1
26	187 - 192	I6	Data set summary record length = 'bbbbbb0'	Copy the value of Level 1.1
27	193 - 198	I6	Number of map projection data records = 'bbbbbb0'	Copy the value of Level 1.1
28	199 - 204	I6	Map projection record length = 'bbbbbb0'	Copy the value of Level 1.1
29	205 - 210	I6	Number of platform position data records = 'bbbbbb0'	Copy the value of Level 1.1
30	211 - 216	I6	Platform position record length = 'bbbbbb0'	Copy the value of Level 1.1
31	217 - 222	I6	Number of attitude data records = 'bbbbbb0'	Copy the value of Level 1.1
32	223 - 228	I6	Attitude data record length = 'bbbbbb0'	Copy the value of Level 1.1
33	229 - 234	I6	Number of radiometric data records = 'bbbbbb0'	Copy the value of Level 1.1
34	235 - 240	I6	Radiometric record length = 'bbbbbb0'	Copy the value of Level 1.1
35	241 - 246	I6	Number of radiometric compensation records = 'bbbbbb0'	Copy the value of Level 1.1
36	247 - 252	I6	Radiometric compensation record length = 'bbbbbb0'	Copy the value of Level 1.1
37	253 - 258	I6	Number of data quality summary records = 'bbbbbb0'	Copy the value of Level 1.1
38	259 - 264	I6	Data quality summary record length = 'bbbbbb0'	Copy the value of Level 1.1
39	265 - 270	I6	Number of data histograms records = 'bbbbbb0'	Copy the value of Level 1.1
40	271 - 276	I6	Data histogram record length = 'bbbbbb0'	Copy the value of Level 1.1
41	277 - 282	I6	Number of range spectra records = 'bbbbbb0'	Copy the value of Level 1.1
42	283 - 288	I6	Range spectra record length = 'bbbbbb0'	Copy the value of Level 1.1
43	289 - 294	I6	Number of DEM descriptor records = 'bbbbbb0'	Copy the value of Level 1.1
44	295 - 300	I6	DEM descriptor record length = 'bbbbbb0'	Copy the value of Level 1.1
45	301 - 306	I6	Number of Radar parameter update records = 'bbbbbb0'	Copy the value of Level 1.1
46	307 - 312	I6	Radar parameter update record length = 'bbbbbb0'	Copy the value of Level 1.1
47	313 - 318	I6	Number of Annotation data records = 'bbbbbb0'	Copy the value of Level 1.1
48	319 - 324	I6	Annotation data record length = 'bbbbbb0'	Copy the value of Level 1.1
49	325 - 330	I6	Number of detail processing records = 'bbbbbb0'	Copy the value of Level 1.1
50	331 - 336	I6	Detail processing record length = 'bbbbbb0'	Copy the value of Level 1.1

**Table 3-20 SAR Trailer file descriptor (3/3)**

Field No.	Byte No.	Type	Description	Remarks
51	337 - 342	I6	Number of Calibration records = 'bbbb0'	Copy the value of Level 1.1
52	343 - 348	I6	Calibration record length = 'bbbb0'	Copy the value of Level 1.1
53	349 - 354	I6	Number of GCP records = 'bbbb0'	Copy the value of Level 1.1
54	355 - 360	I6	GCP record length = 'bbbb0'	Copy the value of Level 1.1
55	361 - 420	10A6	Spare = Blanks	Copy the value of Level 1.1
56	421 - 426	I6	Number of facility data (1) records = 'bbbb0'	Copy the value of Level 1.1
57	427 - 434	I8	Facility data (1) record length = 'bbbbbb0'	Copy the value of Level 1.1
58	435 - 440	I6	Number of facility data (2) records = 'bbbb0'	Copy the value of Level 1.1
59	441 - 448	I8	Facility data (2) record length = 'bbbbbb0'	Copy the value of Level 1.1
60	449 - 454	I6	Number of facility data (3) records = 'bbbb0'	Copy the value of Level 1.1
61	455 - 462	I8	Facility data (3) record length = 'bbbbbb0'	Copy the value of Level 1.1
62	463 - 468	I6	Number of facility data (4) records = 'bbbb0'	Copy the value of Level 1.1
63	469 - 476	I8	Facility data (4) record length = 'bbbbbb0'	Copy the value of Level 1.1
64	477 - 482	I6	Number of facility data (5) records = 'bbbb0'	
65	483 - 490	I8	Facility data (5) record length = 'bbbbbb0'	
66	491 - 496	I6	Number of low resolution image data records = 'bbbb1'	
67	497 - 504	I8	Low resolution image data 1 record length (Variable)	
68	505 - 510	I6	Number of pixels of low resolution image data 1 (Variable)	
69	511 - 516	I6	Number of lines of low resolution image data 1 (Variable)	
70	517 - 522	I6	Number of bytes per one sample of low resolution image data 1 = 'bbbb2'	
71	523- 720	A198	Blanks	

**Table 3-21 Low resolution image data records (1/1)**

Field No.	Byte No.	Type	Description	Remarks
1	1 - i	jBk	Low resolution image data for 16bit i: number of bytes of data j: number of pixels on this record k: size of pixel in bytes = 2	

Characteristics of low resolution image data

- Data type  
16 bit integer
- Record length  
Variable ([Number of pixels] x [Number of lines] x 2)
- Number of records  
1
- Pixel spacing  
Spotlight mode: 50m  
High-resolution mode: 100m  
ScanSAR mode: 500m
- Stored polarization  
Single polarization: HH, HV, VH or VV  
Dual polarization: HH or VV  
Full (Quad.) polarization: Only HH

#### 4. Summary Information

The summary information on CEOS level 2.1 is shown in below.

##### 4.1. Outline of Summary Information

The summary information file includes the information for creating processed data created at ALOS-2 Data Processing System, and it is always made in a pair with its processed data.

##### 4.2. Filename of Summary Information

The filename of summary information is fixed as follows.

summary.txt

##### 4.3. File Format of Summary Information

The summary information file consists of some record lines which use LF (line feed code) as a termination, and does not include header information, footer information, etc. A record line consists of a keyword, a equal mark (=), and a value. A summary information file format outline is shown in Figure 4-1.

Keyword	=	Value	LF
...	...	...	...
Keyword	=	Value	LF

**Figure 4-1 Outline of Summary Information File Format**

##### 4.3.1. Format Definition of Keyword

- (1) The keyword is stored from the head of a record line.
- (2) The equal mark '=' is stored after the keyword.
- (3) There is no blank character between a keyword and '=', in principle.

##### 4.3.2. Format Definition of Value

- (1) The value is a text string bundled with double quotation letters (").
- (2) The value can contain alphabets, digits, and some special characters (except for double quotation). Numerical values are also stored as an ASCII string.
- (3) There is no blank character between '=' and the former double quotation letter, in principle.

#### 4.3.3. Contents of Summary Information

The items of the CEOS Level 2.1 summary information are described in Table 4-1. "b" in a table means blanks.

**Table 4-1 Summary information for CEOS Level 2.1 product (1/8)**

Section	Item name	Keyword	Value	Remark
Ordering information (Odi)	Scene description ID	Odi_SceneId	ID for specifying a scene uniquely 'AAAAAAAAAAAAAAAAA-NNNNN-xxx-nnn' AAAAAAAAAAAAAAAAA: Operation Segment No NNNNN: Observation ID xxx: 001~999 nnn: Scene no.	Copy the value of L1.1
	Processed Site/Date/Time	Odi_SiteDateTime	Spacecraft Control Mission Operation system ='PROCESS: JAPAN-JAXA-ALOS2-SCMObbYYYYMMDDbHHMMSS' Earth Intelligence Collection and Shearing System ='PROCESS: JAPAN-JAXA-ALOS2-EICSbbYYYYMMDDbHHMMSS' YYYYMMDD : Processed date (YYYY: year, MM: month, DD: day) HHMMSS : Processed time (UTC)	
Scene specification (Scs)	Scene ID	Scs_SceneID	'AAAAABBBBBCCCC-YYMMDD' AAAAA : Satellite name (= 'ALOS2') BBBBB : Orbit accumulation number of a scene center CCCC : Scene frame number of a scene center - : separator (hyphen) YYMMDD: Observation date of scene center (YY: lower 2 figures of a year, MM: month, DD: day)	Copy the value of L1.1
	Amount of scene shift	Scs_SceneShift	'-5'~'4' : Except ScanSAR mode '-25'~'20' : ScanSAR mode Zero and positive number have no sign.	Copy the value of L1.1

**Table 4-1 Summary information for CEOS Level 2.1 product (2/8)**

Section	Item name	Keyword	Value	Remark
Product specification (Pds)	Product ID	Pds_ProductID	'DDDEFFFGHI' DDD: Observation mode (*) SBS: Spotlight mode (Single pol.) UBS: Ultra-Fine mode (Single pol.) UBD: Ultra-Fine mode (Dual pol.) HBS: High-sensitive mode (Single pol.) HBD: High-sensitive mode (Dual pol.) HBQ: High-sensitive mode (Full (Quad.) pol.) FBS: Fine mode (Single pol.) FBD: Fine mode (Dual pol.) FBQ: Fine mode (Full (Quad.) pol.) WBS: ScanSAR nominal [14MHz] mode (Single pol.) WBD: ScanSAR nominal [14MHz] mode (Dual pol.) WWS: ScanSAR nominal [28MHz] mode (Single pol.) WWD: ScanSAR nominal [28MHz] mode (Dual pol.) VBS: ScanSAR wide mode (Single pol.) VBD: ScanSAR wide mode (Dual pol.) E : Observation direction (*) L: Left looking, R: Right looking FFF: Processing level 2.1: Level 2.1 G : Processing option G: Geo-Coded H : Map projection type U: UTM, P: PS, M: MER, L: LCC I : Orbit direction (*) A: Ascending, D: Descending	(*) Copy the value of L1.1
	Resampling method	Pds_ResamplingMethod	'NN' / 'BL' / 'CC' Nearest Neighbor / Bi-Linear / Cubic Convolution	
	UTM zone no.	Pds_UTM_ZoneNo	'1'~'60' (specify only for UTM projected product)	



**Table 4-1 Summary information for CEOS Level 2.1 product (3/8)**

Section	Item name	Keyword	Value	Remark
Product specification (Pds)	PS reference latitude	Pds_PS_ReferenceLatitude	Northern Hemisphere: '25.000' <= reference latitude <='90.000' Southern Hemisphere: '-90.000' <= reference latitude <= '-25.000' (specify only for PS projected product)	
	PS reference longitude	Pds_PS_ReferenceLongitude	'-179.999' ≤ reference longitude ≤ '180.000' (specify only for PS projected product)	
	LCC reference latitudinal line 1	Pds_LCC_ReferenceLatitudinalLine1	'-90.000' < reference latitude < '90.000' (specify only for LCC projected product)	
	LCC reference latitudinal line 2	Pds_LCC_ReferenceLatitudinalLine2	'-90.000' < reference latitude < '90.000' (specify only for LCC projected product)	
	Map direction	Pds_MapDirection	'MapNorth'	
	LCC origin latitude	Pds_LCC_OriginLatitude	'-90.000' ≤ origin latitude ≤ '90.000' (specify only for LCC projected product)	
	LCC origin longitude	Pds_LCC_OriginLongitude	'-179.999' ≤ origin longitude ≤ '180.000' (specify only for LCC projected product)	
	Pixel spacing	Pds_PixelSpacing	Spotlight mode: '0.625'/'1.25'/'2.5' [m] Ultra-Fine mode: '2.5'/'5.0'/'10.0' [m] High-sensitive mode: '3.125'/'6.25'/'12.5' [m] Fine beam mode: '6.25'/'12.5' [m] ScanSAR mode: '25.0'/'50.0'/'100.0' [m]	
	Precision of orbit data	Pds_OrbitDataPrecision	'Precision' / 'Onboard' / 'RARR_Predict' Precision : High precision orbit information Onboard : Onboard orbit determination RARR_Predict : Predicted orbit information	Copy the value of L1.1
	Precision of attitude data	Pds_AttitudeDataPrecision	'Onboard' Onboard : Onboard attitude determination	Copy the value of L1.1
Digital Elevation Model	Pds_DigitalElevationModel	'GSMAP_Terrain'/'SRTM90m v4.1' GSMAP_Terrain: GIS MAP Terrain (Hokkaido-Chizu Company Ltd.) SRTM90m v4.1: SRTM 90m Digital Elevation Database v4.1 (CSI)		
Geoid Model	Pds_GeoidModel	'GSIGEO2000'/'EGM96' GSIGEO2000: Japanese Geoid Model (Geospatial Information Authority of Japan) EGM96: Earth Gravitational Model 1996 (NGA)		

A

**Table 4-1 Summary information for CEOS Level 2.1 product (4/8)**

Section	Item name	Keyword	Value	Remark
Image information (Img)	Date and time of scene center	Img_SceneCenterDateTime	'YYYYMMDDbhh: mm: ss.ttt'(UT) YYYY : Year (A.D.) MM : Month (01~12)	Copy the value of L1.1
	Date and time of scene start	Img_SceneStartDateTime	DD : Day (01~31) hh : Hour (00~23) mm : Minute (00~59)	Copy the value of L1.1
	Date and time of scene end	Img_SceneEndDateTime	ss : Second (00~60) (ss=60 is used only by a leap second.) ttt : Milli-second (000~999)	Copy the value of L1.1
	Latitude of image scene center	Img_ImageSceneCenterLatitude	'-90.000'~'90.000' [degree] Third decimal places are not omissible. Zero and positive number have no sign.	
	Longitude of image scene center	Img_ImageSceneCenterLongitude	'-179.999'~'180.000' [degree] Third decimal places are not omissible. Zero and positive number have no sign.	
	Latitude of image scene Left-Top	Img_ImageSceneLeftTopLatitude	'-90.000'~'90.000' [degree] Third decimal places are not omissible. Zero and positive number have no sign.	
	Longitude of image scene Left-Top	Img_ImageSceneLeftTopLongitude	'-179.999'~'180.000' [degree] Third decimal places are not omissible. Zero and positive number have no sign.	
	Latitude of image scene Right-Top	Img_ImageSceneRightTopLatitude	'-90.000'~'90.000' [degree] Third decimal places are not omissible. Zero and positive number have no sign.	
	Longitude of image scene Right-Top	Img_ImageSceneRightTopLongitude	'-179.999'~'180.000' [degree] Third decimal places are not omissible. Zero and positive number have no sign.	
	Latitude of image scene Left-Bottom	Img_ImageSceneLeftBottomLatitude	'-90.000'~'90.000' [degree] Third decimal places are not omissible. Zero and positive number have no sign.	
	Longitude of image scene Left-Bottom	Img_ImageSceneLeftBottomLongitude	'-179.999'~'180.000' [degree] Third decimal places are not omissible. Zero and positive number have no sign.	
	Latitude of image scene Right-Bottom	Img_ImageSceneRightBottomLatitude	'-90.000'~'90.000' [degree] Third decimal places are not omissible. Zero and positive number have no sign.	
	Longitude of image scene Right-Bottom	Img_ImageSceneRightBottomLongitude	'-179.999'~'180.000' [degree] Third decimal places are not omissible. Zero and positive number have no sign.	

**Table 4-1 Summary information for CEOS Level 2.1 product (5/8)**

Section	Item name	Keyword	Value	Remark
Image information (Img)	Latitude of frame scene center	Img_FrameSceneCenterLatitude	'-90.000'~'90.000' [degree] Third decimal places are not omissible. Zero and positive number have no sign.	
	Longitude of frame scene center	Img_FrameSceneCenterLongitude	'-179.999'~'180.000' [degree] Third decimal places are not omissible. Zero and positive number have no sign.	
	Latitude of frame scene Left-Top	Img_FrameSceneLeftTopLatitude	'-90.000'~'90.000' [degree] Third decimal places are not omissible. Zero and positive number have no sign.	
	Longitude of frame scene Left-Top	Img_FrameSceneLeftTopLongitude	'-179.999'~'180.000' [degree] Third decimal places are not omissible. Zero and positive number have no sign.	
	Latitude of frame scene Right-Top	Img_FrameSceneRightTopLatitude	'-90.000'~'90.000' [degree] Third decimal places are not omissible. Zero and positive number have no sign.	
	Longitude of frame scene Right-Top	Img_FrameSceneRightTopLongitude	'-179.999'~'180.000' [degree] Third decimal places are not omissible. Zero and positive number have no sign.	
	Latitude of frame scene Left-Bottom	Img_FrameSceneLeftBottomLatitude	'-90.000'~'90.000' [degree] Third decimal places are not omissible. Zero and positive number have no sign.	
	Longitude of frame scene Left-Bottom	Img_FrameSceneLeftBottomLongitude	'-179.999'~'180.000' [degree] Third decimal places are not omissible. Zero and positive number have no sign.	
	Latitude of frame scene Right-Bottom	Img_FrameSceneRightBottomLatitude	'-90.000'~'90.000' [degree] Third decimal places are not omissible. Zero and positive number have no sign.	
	Longitude of frame scene Right-Bottom	Img_FrameSceneRightBottomLongitude	'-179.999'~'180.000' [degree] Third decimal places are not omissible. Zero and positive number have no sign.	
	Off-nadir angle	Img_OffNadirAngle	NN.N [degree]	Copy the value of L1.1

**Table 4-1 Summary information for CEOS Level 2.1 product (6/8)**

Section	Item name	Keyword	Value	Remark
Product information (Pdi)	Data size of product	Pdi_ProductDataSize	unit: Mbyte = 1024Kbyte Rounded off by the 2nd place of a decimal point. The first place of a decimal is not omissible.	
	Number of files in level 2.1 product	Pdi_CntOfL21ProductFileName	Spotlight mode: 4 files High resolution mode (Single pol.) : 4 files High resolution mode (Dual pol.) : 5 files ScanSAR mode (Single pol.) : 4 files ScanSAR mode (Dual pol.) : 5 files High resolution mode (Full (Quad.) pol.) : 7 files	
	Filename of level 2.1 product	Pdi_L21ProductFileName n nn: 01~99	Volume directory file 'VOL-SSSSSSSSSSSSSSSSSSSS-PPPPPPPPP' Leader file 'LED-SSSSSSSSSSSSSSSSSSSS-PPPPPPPPP' Image file 'IMG-XX-SSSSSSSSSSSSSSSSSSSS-PPPPPPPPP' Trailer file 'TRL-SSSSSSSSSSSSSSSSSSSS-PPPPPPPPP' SSSSSSSSSSSSSSSSSSSS : Scene ID PPPPPPPPP : Product ID XX : Polarization (HH, HV, VH, VV) (in order of Tx-Rx)	
	Bits per pixel	Pdi_BitPixel	'NN' 16: (fixed value)	
	Number of pixels	Pdi_NoOfPixels_0	'0' - '99999' (Zero-suppressible) The number of pixels of the SAR signal data in processed data record (prefix is not included).	
	Number of lines	Pdi_NoOfLines_0	'0' - '99999' (Zero-suppressible) The number of lines of the SAR signal data in processed data record (file descriptor is not included).	
	Product format	Pdi_ProductFormat	'CEOS'	

A

A

A

**Table 4-1 Summary information for CEOS Level 2.1 product (7/8)**

Section	Item name	Keyword	Value	Remark
Result of auto check (Ach)	Checking result of Time data	Ach_TimeCheck	'GOOD' / 'POOR' GOOD: All lines are GPS-aligned, POOR: other than GOOD	Copy the value of L1.1
	Checking result of attitude data	Ach_AttitudeCheck	'GOOD' / 'POOR' GOOD: other than POOR. POOR: There are two or more lines which the posture and the rate are not converging.	Copy the value of L1.1
	Status of absolute navigation	Ach_AbsoluteNavigationStatus	'OK' / 'NG'	Copy the value of L1.1
	Checking result of house keeping data	Ach_HouseKeepingDataCheck	'GOOD' / 'FAIR' FAIR: There are one or more FAIR(s) among check items.	Copy the value of L1.1
	Checking result of orbit data	Ach_OrbitCheck	'GOOD' / 'FAIR' GOOD: All values are normal. FAIR: All abnormal values are interpolated correctly.	Copy the value of L1.1
	Checking result of on-board attitude data	Ach_OnBoardAttitudeCheck	'GOOD' / 'FAIR' GOOD: All values are normal. FAIR: All abnormal values are interpolated correctly.	Copy the value of L1.1
	Loss lines	Ach_LossLines	'GOOD' / 'FAIR' / 'POOR' GOOD: There is no loss line. FAIR: Number of loss line is 1 or more, but is not more than threshold value. POOR: Number of loss line is more than threshold value.	Copy the value of L1.1
	Absolute navigation time	Ach_AbsoluteNavigationTime	blank	Copy the value of L1.1
	Checking result of PRF change	Ach_PRF_Check	blank	Copy the value of L1.1
	Checking result of calibration data	Ach_CalibrationDataCheck	blank	Copy the value of L1.1

A

**Table 4-1 Summary information for CEOS Level 2.1 product (8/8)**

Section	Item name	Keyword	Value	Remark
Result information (Rad)	Practice result code	Rad_PracticeResultCode	'GOOD' GOOD: normal	
Label information (Lbi)	Satellite name	Lbi_Satellite	'ALOS2' (fixed value)	Copy the value of L1.1
	Sensor name	Lbi_Sensor	'SAR' (fixed value)	Copy the value of L1.1
	Processing level	Lbi_ProcessLevel	'2.1'	
	Processing facility	Lbi_ProcessFacility	'SCMO' / 'EICS' SCMO : Spacecraft Control Mission Operation system EICS : Earth Intelligence Collection and Shearing System	
	Observation date	Lbi_ObservationDate	'YYYYMMDD' YYYYMMDD : (YYYY: year, MM: month, DD: day)	Copy the value of L1.1

A